



सत्यमेव जयते

(भारत सरकार)

GOVERNMENT OF INDIA

रेल मंत्रालय (रेलवे बोर्ड)

Ministry of Railways (Railway Board)



# MAINTENANCE MANUAL FOR WAGONS

IRCAMTECH/GWL/MECH/WMM/1.0  
DECEMBER-2015

अअमा सं RDS  
रेल अग्रदूत Transforming Railways



Indian Railways  
Centre for Advanced Maintenance Technology

Maharajpur, Gwalior – 474005 (INDIA)  
Ph: 0751 -2470803 & Fax: 0751 -2470841





(भारत सरकार)  
GOVERNMENT OF INDIA

रेल मंत्रालय (रेलवे बोर्ड)  
Ministry of Railways (Railway Board)



# MAINTENANCE MANUAL FOR WAGON

## **DISCLAIMER**

This Maintenance Manual is solely for the purpose of reference and to be taken as a guide for Railway Staff dealing with the maintenance of Freight Stock.

In case of doubt, codal provisions and the latest Railway Board/RDSO circulars/Letters on the concerned subject should be referred to.



सदस्य यांत्रिक, रेलवे बोर्ड  
एवं  
पदेन सचिव, भारत सरकार  
रेल मंत्रालय  
नई दिल्ली-११० ००१  
MEMBER MECHANICAL, RAILWAY BOARD  
&  
EX-OFFICIO SECRETARY,  
GOVERNMENT OF INDIA  
MINISTRY OF RAILWAYS  
NEW DELHI-110001

## FOREWORD

*The Maintenance manual for Wagons was last compiled and issued by Ministry of Railways in 2001.*

*During the last decades, considerable work has been done in upgrading the wagons to meet the traffic demand for higher productivity. Thus, it has become necessary to update the Wagon Maintenance Manual incorporating the technological upgradations/innovations brought out in the wagon design, maintenance strategy and operation over Indian Railways.*

*The manual deals with maintenance of all systems of the wagons like superstructure, running gear, braking system, etc. Thus, it can act as the single bare reference document for maintenance of wagons in workshops and open line depots. In this manual, the attempt is not to cover the entire range of individual working conditions, which may exist on the various zonal railways. The zonal railways may, if considered necessary, supplement these instructions with subsidiary procedures based on local practices with the approval of CME.*

*Technological upgradation is a continuing process. Those that have been implemented are covered in this manual. With IR's thrust in increased productivity and market orientation, emphasis on factors such as increased throughput in terms of higher axle load and speeds, product specific designs, enhanced reliability and availability etc. will gather momentum ushering in newer designs and technological upgradation of wagons more than ever before. Therefore, separate maintenance instructions will also be issued as and when the newer designs are inducted in to the system.*

*This manual has been written with the purpose of knowledge dissemination and guidance of staff dealing with repairs and maintenance of wagons. Hence full use of the same must be made to derive the intended benefits fully.*

*Apart from detailed maintenance instructions for the different types of wagons now on IR, this manual also lists out various rules and provisions given in IRCA Part-III as a supplement for reference purposes. Statutory provisions and instructions contained in the general rules and various codes are to be followed and remain unaffected by the issue of this manual.*

**(Hemant Kumar)**  
Member Mechanical  
Railway Board



# PREFACE

A comprehensive wagon maintenance manual was published in 2001. A lot of developments have since taken place such as introduction of new wagon stock, stainless steel wagons, permissible loading up to CC+8+2t, introduction of premium examination, introduction of bogie mounted Air brake system(BMBS), Twin pipe air brake system etc.,. As a result, the maintenance pattern and requirements have changed considerably. This has necessitated revision of existing wagon maintenance manual.

Railway Board nominated a committee of officers comprising of Executive Director/CAMTECH/GWL, ED(Wagon)/RDSO/LKO, CRSE/C.Rly/Mumbai and CWM/WRS/KTT vide letter No. 2008/M(N)/951/28 dated 30.10/03.11.2008 for updation and revision of “Indian Railways Unified Maintenance Manual for Wagons”. The revision and updation of manual has been completed taking into account latest fleet of freight stock currently running on Indian Railways.

The present manual bridges this gap and covers detailed treatise of above mentioned issues. The other salient features of the manual are as follows:

- A new chapter titled “INFRASTRUCTURE FACILITIES FOR MAINTENANCE OF FREIGHT STOCK ” has been included in the manual.
- The manual has been divided into logical chapters covering various sub-assemblies and systems. The constructional details and functioning has been explained before describing the detailed maintenance procedures.
- The important dimensions, clearances, material specifications, drawing references etc. have been given immediately after the paragraphs where they have been referred to while describing maintenance procedures.
- Clear sketches and isometric views of the important sub-assemblies/components have been given in the manual.
- Bogie Mounted Brake System for Wagons and various check lists for Inspections have also been included in the chapters.

For convenience of indexing of reference, the paragraphs have been numbered according to a 3 /4 figure “Code”, in which the last two figures give the number of the paragraphs and the remaining figures the number of the chapter. Thus paragraph 101 of any code is paragraph 1 of chapter 1 of that code and paragraph 1103, paragraph 3 of chapter 11.

The page number in each chapter in this manual starts from 1. The reader can easily identify the chapter number to which a page belongs by reading the footer of the page at the bottom where chapter number as well as chapter title is given. This scheme of page numbering is adopted to provide flexibility of easily revising the chapters in future, on account of design or procedure changes or induction of new stock without disturbing the page numbers of succeeding chapters.

The tables in each chapter consist of two numbers separated by a decimal point. The number before decimal point indicates the chapter number whereas the number after the decimal point indicates the running serial number of the table which start from 1 in every chapter. The convention adopted for numbering the figures is also identical to the numbering scheme adopted for the tables.

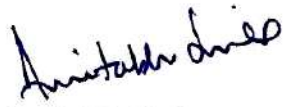
The items of maintenance required to be carried out in sick-line, ROH & POH have been listed out separately towards the end of various chapters under appropriate headings for each system/sub-assembly covered in the manual for easy reference and guidance of maintenance units.

Future addition/ deletion/ modification to this manual will be processed by RDSO and will be required approval of the Railway Board.

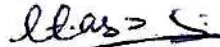
The Committee is thankful to Shri D.K. Saraf, Addl. Member/Plg., Railway Board, Shri Ashesh Agrawal, EDME(Fr.), Railway Board, Shri Anirudh Kumar, Director/wagon, RDSO, Shri Roopesh Kohli, Director/wagon, RDSO and **Shri K.P.Yadav, Director/Mechanical, CAMTECH** for their valuable contribution in finalisation of this manual. Members of the committee also express their appreciation for the valuable assistance provided by Shri V.K.Agrawal the then Director/Wagon/RDSO and Shri K.S. Jain, Director Wagon/RDSO/LKO, Shri Sanjeev Kumar Sr.CTA/CAMTECH & Shri R.K.Dwivedi, Sr CTA/CAMTECH.



**A.R. Tupe**  
Exe. Director  
CAMTECH



**Amitabh Sinha**  
Exe. Director Std. (W)  
RDSO



**P. Lamghare**  
CRSE(Freight)  
C.Rly.



**Kundan Kumar**  
CWM/WRS/KTT  
WC Rly



# CONTENTS

FOREWORD	i
PREFACE	ii
CONTENTS	iii
CORRECTION SLIPS ISSUED	iv

## **CHAPTER 1**

<b>INTRODUCTION</b>	<b>Page 1-51</b>
101. General	1
102. Important parameters of Wagons	2
103. Important Rule Books and References	5
104. Standard Infrastructure for Wagon Depot	7
105. Important Wagon Modifications	7
106. Numbering Convention in the Manual	7
107. Numbering of Tables and Figures in the Manual	7
108. Standard Features of Wagons	7
Appendix	8-51

## **CHAPTER 2**

<b>MAINTENANCE WARRANTY AND CONDEMNATION</b>	<b>Page 1-21</b>
201. Warranty Inspection of newly built wagons	1
202. Examination and Maintenance Periodicity	6
203. ROH of Wagons with CASNUB Bogie	7
204. Categorization of Wagon repair	8
205. Condemnation of Wagons	10
206. POH and ROH Interval	12
207. Work Areas where attention to be given	14
Table 2.3	15-21

## **CHAPTER 3**

<b>YARD MAINTENANCE</b>	<b>Page 1-44</b>
301. Notification of Examination Points	1
302. Pattern of Freight Train Examination	1
303. Guidelines for GDR Check	5
304. General conditions for Freight Train Examination	6
305. Steps of Freight Train Examination	6
306. Details of Freight Train Examination	7
306A Rolling in / Terminating Examination	7
306B Freight Train Examination and Repairs	7
306C Air Brake Testing of Rakes having single pipe brake system	8
306D Air Brake Testing of Rakes having Twin pipe brake system	9
306E Common Problems in BMBS and Remedies	17
306F Issue of Brake Power Certificate	19

307.	Procedure for Examination and Safety Certification of Departmental Rolling Stock	20
308.	Important Parameters to be ensured during Train Examination	21
308A	Brake Gear Limit and Clearances	21
308B	Piston Stroke	22
308C	Buffer Height	22
309.	Important Parameters to be ensured during Sick line/Depot attention	22
309A	Nominal Clearances of CASNUB Bogies	22
309B	Wear Limits	22
309C	Load/Snubber Springs of CASNUB Bogie	23
309D	Wear Limit for Friction Wedge block	23
309E	Centre Pivot wear limit	23
309F	Elastomeric Pad and constant contact side bearer	23
309G	Wheel and Axle	24
310.	Infrastructure & Facilities required in the yard	24
311.	Machinery & Plant items	24
312.	Tools Required	24
313.	Man Hours for various types of Examinations	24
314.	Examination of Container Trains (BLC/BLL Rakes)	26
315.	Standardization of Brake Power Certificates for various Train Examinations	27
	End to End Examination Format –I	28
	Premium Examination Format –II	31
	Close Circuit Examination Format- III	34
	Table 3.3- Categorization of Freight Train Examination Points	38
	Table 3.4- Distribution of Staff, Gangwise with tools & Materials	44
	Table 3.5- Warranty Periods of Various Freight Stock Items	45

#### **CHAPTER 4**

##### **WAGON BODY**

**Page 1-28**

401.	Introduction	1
402.	General Construction of Open Wagon	1
403.	General Construction of Covered Wagon	1
404.	General Construction of Flat Wagon & Well Wagon	2
405.	General Construction of Hopper Wagon	2
406.	Nature of Repairs required in Wagon body	3
407.	Corrosion in Wagon Body	3
408.	Anticorrosive Measures	4
409.	Rejectable Defects	4
410.	Repairs in Sickline and ROH Depot	4
410A	Panel Patching	4
410B	Procedure for Welded Patches	6
410C	Riveted Patch	10
410D	Repairs to Bulged ends	10
410E	Repairs to Body Structural members (Stanchions, Carlines & Copings)	10
410F	Water Tightening of Wagons	10
410G	Repairs to Doors and Door fittings (for Mild Steel wagons)	11

410H	Repairs to Doors & Door fittings (for BCNHL Wagons)	12
410I	Cleaning, Surface preparation & Painting	20
411.	Repair and Maintenance in Workshops during POH and NPOH	21
412.	Important Precautions to be taken while carrying out welding	21
413.	Important Do's and Don'ts	22
414.	Maintenance of Stainless Steel Wagons	22
415.	Upgraded rehabilitation of BOXN to BOXNR	22
416.	Lock Bolts	24
417.	New Wagon Numbering Scheme	26

## **CHAPTER 5**

### **UNDER FRAME**

**Page 1-14**

501.	General	1
502.	General Construction of BG Wagon Underframe	1
503.	Need of the repairs to Bogie Wagon Underframe for mild steel wagons	9
504.	Repair Procedure	9
505.	Cleaning and De-rusting of the Underframe	10
506.	Repairs to Head Stock	10
507.	Repairs to Diagonals and Cross Bars	10
508.	Repairs to Sole Bars	10
509.	Repairs to Floor Plate	11
510.	Underframe of Brake Van	11
511.	BVZI Brake Van	12
512.	List of Modifications	12
513.	Repair and Maintenance in Sick-line and ROH Depot	14
514.	Repair and Maintenance in Workshop during POH/NPOH	14

## **CHAPTER 6**

### **BOGIES AND SUSPENSION**

**Page 1-43**

601.	CASNUB Bogie	1
602-605.	Fabricated BOX Bogie (UIC)	16
606.	Wheel Assembly	16
607.	Grease for CTRBs	26
608.	Maintenance & Repair of Cartridge Tapered Roller Bearings	27
609.	Arrangement of springs in various CASNUB trolleys	36

## **CHAPTER 7**

### **AIR BRAKE SYSTEM**

**Page 1-151**

701.	Classification of Air Brake System	1
702.	Principle of Operation of Single Pipe Graduated Release Air Brake System	1
702A	Principle of Operation of Twin Pipe Graduated Release Air Brake System	4
703.	Common Pipe Bracket	6
704.	Intermediate Piece (Sandwich piece)	7
705.	Brake Pipe Hose	7
706.	Brake Pipe Coupling	7
707.	Cut Off Angle Cock	10
708.	Brake Cylinder	14

709.	Dirt Collector	19
710.	Auxiliary Reservoir	23
711.	Guard's Emergency Brake Valve	24
712.	Slack Adjuster	27
713.	Distributor Valve	39
714.	C3W Distributor Valve	39
715.	Testing of Distributor Valve	54
715A	Purpose of conducting various tests	54
715B	Tools and Equipments for Testing	57
716.	Testing of C3W Distributor Valve	57
717.	KE Distributor Valve	62
718.	Testing of KE Distributor Valve	71
719.	Test Report Proforma for C3W/KE Distributor Valve	74
720.	Single Wagon Test	76
720A	Procedure for Single Wagon Testing (Single Pipe)	77
720B	Procedure for Single Wagon Testing (Twin Pipe)	77
720C	Proforma for SWT for wagons other than BOBR & BOBRN (Single & twin)	80
720D	Proforma for SWT for wagons BOBRN type (Single & twin)	81
720E	Proforma for SWT for wagons BMBS type (Single & twin)	83
	Table 7.0 APM Setting	85
721.	Rake Test	88
722.	Repair and Maintenance in Sick-line	95
723.	Repair and Maintenance in ROH	96
724.	Periodical Overhaul of Air Brake System	98
725.	Details of Tools, Fixtures and Equipments	101
726.	Brake Power Calculations for BOXN wagon	104
727.	Brake Rigging	105
728.	Composition Brake Block	110
729.	Bogie Mounted Brake System (BMBS)	113

## **CHAPTER 8**

### **DRAW AND BUFFING GEAR**

**Page 1-38**

801.	General	1
802.	Centre Buffer Coupler and Draft Gear	1
803.	Parts of Centre Buffer Coupler Assembly	2
804.	Inspection of CBC	2
805.	Inspection of Draft Gear (MK-50 & RF-361)	4
806.	Removal of Coupler and Draft Gear from Wagons	5
807.	CBC Measuring Gauges and their Applications	6
808.	Development of High Tensile Coupler & High Capacity Draft Gear	18
809.	RF-361 Draft Gear	19
810.	Maintenance of Mark-50 Draft Gear	27
811.	Action Plan to reduce train parting	32
	Vendor List	33
	Marking on CBC (Manufacturers Initial)	37

## **CHAPTER 9**

### **TANK WAGON**

**Page 1-25**

901.	Constructional Details	1
902.	Periodicity of Overhauling of Tank Wagon	4
903.	Cleaning of Tanks for Corrosive Liquids	5
904.	Inspection of Tank Barrels	6
905.	Testing of Barrel	6
906.	Barrel Test Pressure	7
907.	Testing of Tanks used for Corrosive Liquids	7
908.	Testing of Tank Wagons used for Petrol and Middle Distillates of Petroleum and Vegetable Oils	7
909.	Repairs to Tank Barrels by Welding	7
910.	Repairs and Testing of Tank Barrel Mounting Fittings	10
911.	Fittings of Tanks for Corrosive Liquids	11
912.	Fittings of Tank Wagons of Petrol, other inflammable products, vegetable oils, etc.	11
913.	Test Reports and Records of Inspection	12
914.	Important Modifications	12
915.	Painting and Lettering	12
916.	Examination and Repair of Tank Wagons by C&W Supervisor in sick line	15
917.	Precautions with leaky Tank Wagons	15
918.	Precautions to be taken at Loading and Unloading Points (Tanks as Pressure Vessels)	17
919.	Loading and Unloading Corrosive Liquids	19
920.	Loading and Unloading of Tank Wagons	20
921.	Precautions for Tanks for Petroleum and other inflammable products	20
922.	Maintenance and Repair in Sick line	21
923.	Maintenance and Repair in Workshop during POH	22
924.	Instruction for maintenance & Operation of Bogie petrol tank wagon type BTPN	23
925.	Prevention of fire risks due to proximity of sealing wires with contact wire of OHE.	24
	Table 9.5: List of RDSO maintenance publications for Tank Wagons	25

## **CHAPTER 10**

### **SPECIAL TYPE OF WAGONS**

**Page 1-13**

1001.	BOXNCR WAGONS	1
1002.	BOGIE LOW PLATFORM CONTAINER FLATS (BLC)	3
1003.	BROAD GAUGE BOGIE CONTAINER FLAT WAGON (BLLA & BLLB)	6
1004.	BOGIE COVERED DOUBLE DECKER WAGON TYPE 'BCACBM'	8
	Table 10.3 NEW VARIANTS OF OLD WAGONS	9

## **CHAPTER 11**

### **INFRASTRUCTURE FACILITIES**

**Page 1-15**

1101	Introduction	1
1102.	Infrastructure and facilities required in the Yards	2
1103	Infrastructural Facilities for Freight Examination Yard with World-Class Facilities for detachment-free Yard	4

1104	Infrastructural Facilities in Air Brake ROH Depots	5
1105	Facilities required for maintenance of Stainless Steel Wagons	11
1106	Minimum infrastructure required for Premium & CC examination	12
1107	Facilities required in Freight Examination Yards	13

## **LIST OF APPENDICES**

APPENDIX-I	Tippler	1 to 6
APPENDIX-II	List of Important Modifications to be carried out on Freight stock	1 to 2
APPENDIX-III	Wagon Manufacturers and Workshops	1 to 4
APPENDIX-IV	Branding details on Wheel and Axle	1 to 4
APPENDIX-V	List of Must change items in Freight stock during POH and ROH	1 to 5
APPENDIX-VI	Guidelines for Maintenance and Repair of Stainless Steel Wagons	1 to 14
APPENDIX-VII	Long Haul Train Operation	1 to 5
APPENDIX-VIII	Check List for Inspection of Wagon stock.	1 to 43
APPENDIX-IX	Bogie Covered Double Decker Wagon type 'BCACBM'	1 to 15
APPENDIX-X	Proposed Electronic Equipments for Freight Stock	1 to 4
APPENDIX-XI	Duty Lists of C&W Supervisors	1 to 33
APPENDIX-XII	Unit Exchange Spares for Freight Stock in ROH Depots	1 to 1

*( MAINTENANCE MANUAL FOR WAGONS- 2015 )*

# CHAPTER - 1



# INTRODUCTION





# CHAPTER 1

## INTRODUCTION

### 101. GENERAL

A comprehensive Wagon Maintenance Manual was published in 2001. A lot of developments have taken place such as introduction of new stock, stainless steel wagons, permissible loading up to CC+8t+2t, introduction of premium examination, introduction of bogie mounted Air brake system, Twin pipe air brake system etc,. As a result, the maintenance pattern and requirements have changed considerably. This has necessitated revision of existing wagon maintenance manual.

- a) For ensuring optimum performance of wagon fleet, it is necessary that:
- Preventive maintenance is given timely to avoid occurrence of defects
  - Defects are attended effectively and well in time so that the wagons remain fit for traffic use till the next schedule falls due
  - Detention during examination and repairs is kept to minimum
  - Frequent failures of similar nature are studied and necessary modifications/ design changes are effected to eliminate the cause of such failure.

In course of time and based on experience, various procedures/ schedules for maintenance of wagons have been prepared. The schedules and procedures have been largely standardized and issued by Railway Board, RDSO, and IRCA etc. However, in many cases, instructions have been issued in piecemeal. This manual consolidates various standing instructions issued on wagon maintenance and lays down guidelines for ensuring uniformity in the practices to be followed on various railways. The important aspects of wagon maintenance have been covered and wherever necessary, the references are indicated so that the reader can refer these, if necessary, for detailed instructions and procedures not contained in this manual.

- b) This manual does not deal with the special stock or ODCs for which separate instructions are issued by RDSO/manufacturers.
- c) At the end of this chapter, the list of important instructions and references has been given. Throughout this manual, wherever IRCA Part III has been mentioned, it refers to IRCA Part-III (Latest edition).
- d) While proper maintenance plays a vital role in ensuring effectiveness of the rolling stock, an equally crucial role is played by proper handling and careful operation of the wagon fleet so as to minimise the incidences of damage and subsequent need for repairs.

## 102. IMPORTANT PARAMETERS OF WAGONS

The important dimensions and sketches of main type of wagons stock used over Indian Railways are provided in this chapter.

Details of following new type of wagon stock have been added. *Regarding latest position of axle load, spring configuration and permissible speed, RDSO's instructions may be referred. The speed certificates of these wagons are available on RDSO 's website.*

**TABLE 1.1 OPEN WAGONS**

Designation	Axle Load	Bogie	Springs	Permissible Speed Loaded/Empty	Remarks
BOY	22.9 t	Casnub 22 NLB (modified)	O – 14 I – 10 S – 4	65/ 75 Kmph	It has no doors. Designed for heavy minerals.
BOYEL	25.0 t	Casnub 22 NLC	O – 14 I – 14 S – 4	45+5/ 60+5 Kmph	Min. wheel tread dia. 950 mm.
BOXN	20.32 t	Casnub 22 NLB	O – 12 I – 8 S – 4	75/ 80 Kmph	Operation at CC +6 +2/ CC +8 +2 allowed as interim measure, with speed restriction 60/80
BOXN M1	22.82 t	Casnub 22 NLB (Modified)	O – 14 I – 10 S – 4	70/ 80 (CC +6 +2) 60/ 80 (CC +8 +2) Kmph	On specified routes the speed is 75/80 Kmph with CC +8 +2
BOXNEL	25.0 t	Casnub 22 NLC	O – 14 I – 14 S – 4	50/ 65 Kmph	Min. wheel tread dia. 950 mm
BOXNHS	20.32 t	Casnub 22 HS	O – 14 I – 12 S – 4	100/ 100 Kmph	-
BOXNHS M1	22.82 t	Casnub 22 HS (Modified)	O – 14 I – 14 S – 4	75/ 90 (CC +6 +2) 60/ 90 (CC +8 +2) Kmph	On specified routes the speed is 75/80 Kmph with CC +8 +2
BOXNHA	22.1 t	IRF 108 HS	O – 14 I – 14 S – 4	100/100 Kmph (20.32 & 22.1 t) 75/100Kmph(22.82 t)	-
BOXNLW	20.32 t	Casnub 22 HS	O – 14 I – 12 S – 4	100/ 100 Kmph	Stainless steel (IRS: M44) and Corton Steel (IRS: M41) used in body & under frame
BOXNLW M1	22.82 t	Casnub 22 HS (Modified)	O – 14 I – 14 S – 4	<b>60/ 65</b> Kmph	-
BOXNHL	22.9 t	Casnub 22 HS	O – 14 I – 14 S – 4	75/ 100 Kmph	IRS: M44 (Body), Flat centre Pivot, K type CBB, Improved Coupler & draft gear Br. Cyl, 300 mm, IRSA 750 Slack Adj., A.R. 75 litres, PU Painting (Phirozi colour)
BOST	20.32 t	Casnub 22 HS	O – 14 I – 12 S – 4	75/ 80 Kmph	Operation at CC+ 6 + 2 allowed as an interim measure with speed restriction to 50/ 80
BOSTM1	22.32 t	Casnub 22 HS (modified)	O – 14 I – 14 S – 4	60/ 65 Kmph	High Axle load version of BOST
BOSTHS	20.32 t	Casnub 22 HS (mod- I)	O – 12 I – 12 S – 4	100/ 100 Kmph	High Speed version of BOST
BOSTHS M1	22.32 t	Modified Casnub 22 HS (Mod- I)	O – 14 I – 14 S – 4	60/ 80 Kmph	High Axle load version of BOST HS

Designation	Axle Load	Bogie	Springs	Permissible Speed Loaded/Empty	Remarks
BOSTHS M2	22.32 t	Modified Casnub 22 HS (Mod- II)	O – 12 I – 12 S – 4	60/ 100 Kmph	Design of suspension is different than BOSTHS M1.
BOXNHAM	22.82 t	IRF 108 HS	O – 14 I – 14 S – 4	75/ 100 Kmph	-
BOXNR	22.9 t	Casnub 22 NLB	O – 12 I – 8 S – 4	75/ 80 Kmph	Rehab wagon with replacement of end wall & side walls in POH
BOMN	16.4 t	Casnub 22 NLB	O – 12 I – 8 S – 4	80/75 Kmph	Bogie open Military wagon for defence equipments.

**TABLE 1.2 COVERED WAGONS**

Designation	Axle Load	Bogie	Springs	Permissible Speed (in Kmph)	Remarks
BCN	20.32 t	Casnub 22 NLB	O – 12 I – 8 S – 4	75/ 80 Kmph	Permitted with CC +6 +2 also.
BCN M1	22.82 t	(Modified) Casnub 22 NLB	O – 14 I – 10 S – 4	75/ 80 (CC +6 +2) 60/ 80 (CC +8 +2) Kmph	High axle load version of BCN
BCNHS M1	22.82t	(Modified) Casnub 22 HS	O – 14 I – 14 S – 4	75/ 90 (CC +6 +2) 75/ 90 (CC +8 +2) Kmph	High axle load version of BCNHS
BCNA	20.32 t	Casnub 22 NLB	O – 12 I – 8 S – 4	80/ 80 Kmph	Permitted with CC +6 +2 also.
BCNA M1	22.82 t	(Modified) Casnub 22 NLB	O – 14 I – 10 S – 4	75/ 80 (CC +6 +2) 60/ 80 (CC +8 +2) Kmph	High axle load version of BCNA
BCNAHS	20.32 t	Casnub 22 HS	O – 14 I – 12 S – 4	100/ 100 Kmph	Variant of BCNA with Casnub bogie 22 HS bogie
BCNAHS M1	22.82 t	(Modified) Casnub 22 HS	O – 14 I – 14 S – 4	75/ 100 (CC +6 +2) 75/ 100 (CC +8 +2) Kmph	High axle load version of BCNA HS
BCNHL	22.9 t	Casnub 22 HS	O – 14 I – 14 S – 4	75/ 70 Kmph	Length reduced, width and height increased than BCNA. Under frame mounted No. of wagons/ rake = 58 Flat centre Pivot, K-type CBB, improved coupler & draft gear, Brake cylinder 300 mm, A.R. 75 liters, PU painting (Phirozi).
BCNHL	22.9 t	Casnub 22 HS	O – 14 I – 14 S – 4	75/ 70 Kmph	With BMBS
BCCN End wagon A Middle Wagon B	10.425 t 10.50 t	IRF 106 HS	O – 14 I – nil S – 4	100 Kmph	Maruti Car Double decker
BCCW	20.32 t	Casnub 22 NLB	O – 12 I – 8 S – 4	70 Kmph (Specific Route)	Cement Wagon
BCCW	21.82 t	Casnub 22 HS	O – 14 I – 14 S – 4	65 Kmph	Cement Wagon
BCBFG	21.82 t	Casnub 22HS (Mod.1)	O – 14 I – 14 S – 4	75 Kmph (Specific Route)	Food Grain hopper wagon

**TABLE 1.3 FLAT WAGONS**

Designation	Axle Load	Bogie	Springs	Permissible speed Loaded/Empty	Remarks
BRN	20.32 t	Casnub 22 NLB	O-12 I-8 S-4	75/ 80 Kmph	Designed for rails and heavy steel products.
BRN22.9	22.9 t	Casnub 22 HS	O-14 I-14 S-4	65/ 65 Kmph	Improved version of BRN
BRNA	20.32 t	Casnub 22 NLB	O-12 I-8 S-4	75/ 80 Kmph	Improved version of BRN, Higher pay to tare ratio.
BRNAHS	20.32 t	Casnub 22 HS	O-14 I-12 S-4	100/ 100 Kmph	High speed variant of BRNA
BFNS	20.32 t	Casnub 22 HS	O-14 I-12 S-4	100/ 100 Kmph	Designed for transportation of steel coils, plates, sheets & billets etc.
BRHNEHS	20.32 t	Casnub 22 HS	O-14 I-12 S-4	65/ 65 Kmph	Bogie rail wagon designed for Track Relaying trains (TRT) specially for loading RCC sleepers.
BRSTN	20.32 t	Casnub 22 NLB	O-12 I-8 S-4	80/ 75 Kmph	Bogie rail wagon for heavy vehicles.
BWTB	22.9 t	Casnub 22 NLB	O-14 I-10 S-4	65/ 65 Kmph	Bogie well wagon (well height 1055 mm).

**TABLE 1.4 HOPPER WAGONS**

Designation	Axle Load	Bogie	Springs	Permissible Speed	Remarks
BOBSN	22.9 t	(modified) Casnub 22 NLB	O-14 I-10 S-4	75/ 75 Kmph	Designed in 1994 for transportation of Iron ore, side discharge.
BOBSN M1	25 t	Casnub 22 NLC	O-14 I-14 S-4	50/ 60 Kmph	High axle load variant of BOBSN. Casnub 22 NLC Bogie.
BOB R	20.32 t	Casnub 22 NLB	O-12 I-8 S-4	80/ 80 Kmph	Designed in 1986 for coal. Bottom discharge. No. of wagons/ rake = 53.
BOBR M1	22.32 t	(Modified) Casnub 22 NLB	O-14 I-10 S-4	70/ 75 Kmph	(CC + 6 + 2) version of BOBR.
BOB RN	20.32 t	Casnub 22 NLB	O-12 I-8 S-4	70/ 75 Kmph	Designed in 1991 by reducing the length of BOBR. No. of wagons/ rake = 58.
BOBRN M1	22.32 t	(Modified) Casnub 22 NLB	O-14 I-10 S-4	70/ 80 Kmph	(CC + 6 + 2) version of BOBRN.
BOBRNHS	20.32 t	Casnub 22 HS	O-14 I-12 S-4	100/ 100 Kmph	High speed BOBRN
BOBRNHS M1	22.32 t	(Modified) Casnub 22 HS	O-14 I-14 S-4	60/ 65 Kmph	--
BOBRNEL	25 t	Casnub 22 NLC	O-14 I-14 S-4	45+5/ 60+5 Kmph	25 t axle load. Wheel dia 1000 mm. POH-6 years, ROH-2 years.
BOBYN	20.32 t	Casnub 22 NLB	O-12 I-8 S-4	75/ 75 Kmph	Air Brake version of BOBY. Designed in 1996
BOBYN22.9	22.9 t	Casnub 22 HS	O-14 I-14 S-4	75/ 75 Kmph	Air Brake version of BOBYHS.
BCBFG	21.82 t	Casnub 22 HS (Mod-I)	O-12 I-12 S-4	75/ 75 Kmph	Bogie covered Hopper Wagon for food grains. Designed with automatic LSD.

**TABLE 1.5 TANK WAGONS**

Designation	Axle Load	Bogie	Springs	Permissible Speed	Remarks
BTALN	20.32 t	UIC Bogie	--	65/ 65 Kmph	Bogie Ammonia Tank Wagon
BTPN	20.32 t	Casnut 22 NLB	O – 12 I – 8 S – 4	80/ 75 Kmph(Loaded)	Bogie POL Tank Wagon
BTPGLN	19.8 t	Casnut 22 NLB	O – 12 I – 8 S – 4	75/ 80 Kmph	Bogie LPG Tank Wagon. Variant of BTP GL with Air Brakes / Casnut 22 NLB bogie.
BTCS	20.32 t	Casnut 22 W	O – 12 I – 8 S – 4	65/ 65 Kmph	Bogie Caustic Soda Tank Wagon. Provisional speed certificate is with casnut 22W bogie. In 2007, bogie altered to NLB in the drawing.
BTAP	20.32 t	Casnut 22 NLB	O – 12 I – 8 S – 4	65/ 65 Kmph	Bogie Alumina Tank Wagon.
BTFLN	20.32 t	Casnut 22 HS	O – 14 I – 12 S – 4	65/ 65 Kmph (Provisional)	Bogie POL Tank Wagon

**TABLE 1.6 CONTAINER WAGONS**

Designation	Axle Load	Bogie	Springs	Permissible Speed	Remarks
BLLA/ B	20.32 t	LCCF 20 (c)	O – 14 I – 12 S – 4	100/ 100 Kmph	Bogie low platform longer container flat wagon.
BLCA/ B	20.32 t	LCCF 20 (c)	O – 14 I – 12 S – 4	100/ 100 Kmph	Bogie low platform container flat wagon
BLCAM/ BLCBM	22 t	Modified LCCF 20 (c)	O – 14 I – 14 S – 4	90/ 100 Kmph	In 2007, bogie of BLC wagon was modified by providing upgraded side bearer, upgraded friction wedge, and two additional inner springs for double stack container operation.
BCACM	20.32 t	LCCF 20 (c)	O – 14 I – 12 S – 4	65/ 75 Kmph	For auto car industry
BCACBM	A-12.715 t B-12.680t	LCCF 20 ©	O – 14 I – 12 S – 4	100/95 Kmph	For transportation of Automobile cars.

**TABLE 1.7 BRAKE VAN**

Designation	Axle Load	Bogie	Springs	Permissible Speed	Remarks
BVZI	5.875 t	ICF Bogie	-	100 Kmph	Designed in 2000 with ICF Bogie to achieve comfortable ride, 5 m longer than BVZC.
BVZC	06.98 t	4- wheeler	-	100 Kmph	RDSO Drg. No. WD- 81035/S-2

### 103. IMPORTANT RULE BOOKS AND REFERENCES

List of Technical Monographs/Instructions relevant to maintenance of Freight stock are included in the compendium of instructions/ technical monographs issued vide Railway Board's letter No. 2004/M(N)/951/16 Dt. 18.5.2004. The following rule books, pamphlets and monographs contain information required to supplement this manual. These may be referred to for details, if not available in this manual.

S.N	IRCA/RDSO publication	Description	Latest edition/ correction
01	IRCA Conference Rules Part III	Rules for Maintenance, Examination & Interchange of Goods Stock of Indian Government Railways.	(Latest edition)
02	G-33(Rev.1)	Technical Pamphlet for requirements of Tippler Installation for approval by RDSO	May.2010
03	G-37(Rev.1)	Recommended Practice for Welded fabrication in Wagons	April.1971
04	G-70	Maintenance manual for BOXN wagon	Aug.1998
05	G-71	Maintenance manual for Phosphoric acid Tank Wagon	Feb.1999
06	G-72	General Std. Spec. For Fabrication of Wagon 'U' frame & Bogies	Oct.2001 & Corrigendum No.1 of Nov. 2002.
07	G-73	Operation and Maintenance Manual for BOBR/BOBRN	Rev.I of oct.2005
08	G-76	Inspection and Maintenance of CBC for Line Staff	1987
09	G-79	Inspection and Maintenance of BTAL /BTALN	April.1999
10	G-80	Inspection and Maintenance of CBC for Workshop	1989
11	G-81	Inspection and Maintenance of Cartridge Roller Bearing fitted on Casnub Bogie	Feb.2000
12	G-82	Instructions for operation and maintenance of B.G.Bogie tank wagon for Alumina type 'BTAP'	June.1986
13	G-83	Instructions for Maintenance and Operation of Bogie Caustic Soda tank wagon type 'BTCS'	Aug. 1988
14	G-85	Operation and maintenance Instructions for Sliding roof covering on 'BOXN(S)'	Apr.1989
15	G-86	Maintenance Manual for Bogie Liquefied Petroleum Gas Tank Wagon type BTPGL	Dec.1999
16	G-87	Safe handling of Hazardous chemicals transported in Rail Tankers.	-
17	G-90	Maintenance and Operating Instruction for Bogie Petroleum Tank Wagon type 'BTPN'	July.2012
18	G-92	Maintenance Manual for IRSA-600, IRSA-600J type slack adjusters used on Freight Stock and IRSA-450 slack adjusters used on Coaching stock	Sept.1998
19	G-95	Instructions for Inspection and Maintenance for Casnub Bogies	June.2003
20	G-97	Maintenance Manual for Air Brake System for Freight Stock	July 2001
21	G-100	Technical Pamphlet for Instructions & Maintenance of Automatic Twist Lock (ATL) devices fitted on Container flat wagons.	July.2010 & May.2012
22	G-103	Technical Pamphlet on strengthening of underframe, repair of critical weld joints, repair of centre sill, Centre girders and sole bar cracks	Nov.2010 May.2011(Rev.2)
23	G-106	Bogie Covered Double Decker Wagon type 'BCACBM'	Feb, 2014
24	G-107	Procedure for re-cambering of bogie Rail wagon type BRN/BRNA/BRNHS .	
25	WT-77-I	Instructions for inspection and maintenance of 20.3 tonne Roller Bearing axle boxes fitted on wagon.	Dec.1985
26	WT-79-I	Instructions for inspection and maintenance of 16.3 tonne Roller Bearing axle boxes fitted on wagon.	1987

**104. STANDARD INFRASTRUCTURE FOR WAGON DEPOT**

A separate **Chapter No 11** for standard infrastructure required in wagon depots has been added.

**105. IMPORTANT WAGON MODIFICATIONS**

The list of important modifications to be carried out on freight stock is given in Appendix-II.

**106. NUMBERING CONVENTION IN THE MANUAL**

For convenience of indexing of reference, the paragraphs have been numbered according to a 3 /4 figure “Code”, in which the last two figures give the number of the paragraphs and the remaining figures the number of the chapter. Thus paragraph 101 of any code is paragraph 1 of chapter 1 of that code and paragraph 1103, paragraph 3 of chapter 11.

The page number of each chapter in this manual starts from 1. The reader can easily identify the chapter number to which a page belongs by reading the header of the page where chapter number as well as chapter title is given. This scheme of page numbering is adopted to provide flexibility of easily revising the chapters in future, on account of design or procedure changes or induction of new stock without disturbing the page numbers of succeeding chapters.

**107. NUMBERING OF TABLES AND FIGURES IN THE MANUAL**

The tables in each chapter consist of two numbers separated by a decimal point. The number before decimal point indicates the chapter number whereas the number after the decimal point indicates the running serial number of the table which starts from 1 in every chapter. The convention adopted for numbering the figures is also identical to the numbering scheme adopted for the tables.

**108. STANDARD FEATURES OF WAGONS**

Important features and lay out of the wagons are given in the following appendix-A. Technical data and other important parameters are also available in this appendix for ready reference.

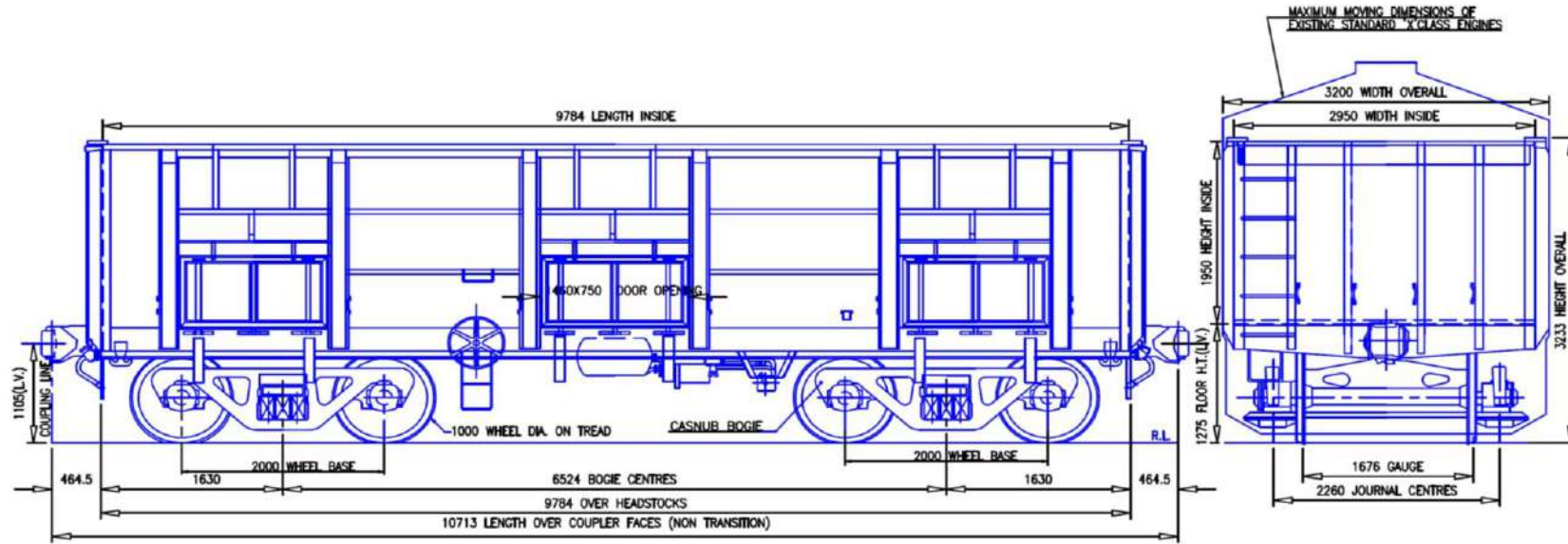


FIG. 1.1 BOXN WAGON (RDSO Drg. No. WD- 80007/ S-2)

**INTRODUCTION:** - BOXN wagon has been designed for transportation of iron ores, coal etc. either fitted with Casnub-22W/ Casnub-22W(M)/Casnub 22 NLB bogies, non-transition center buffer couplers and single-pipe graduated release air brake system.

**STANDARD FEATURES OF ‘BOXN’ WAGON**

S.No	PARTICULARS	Parameter	S.No	PARTICULARS	Parameter
1	Length over head stock (mm)	9784	14	Cubic Capacity (Cu.M)	56.29
2	Length over couplers (mm)	10713	15	Maximum axle load (tonne)	20.32
3	Length inside (mm)	9784	16	Tare Weight (tonne)	23.2
4	Width inside/Width Overall (mm)	2950/3200	17	Pay load (tonne)	58.08
5	Height inside/Height (max.) from R.L.	1950/3233	18	Gross load (Pay+Tare) (tonne)	81.28
6	Bogie centers (mm)	6524	19	Ratio gross load/Tare	3.5
7	Journal length × dia. (mm)	144x278	20	Ratio (Pay load to tare)	2.5
8	Journal centers (mm)	2260	21	Track Loading density (tonnes/meter)	7.59
9	Wheel dia. on tread (New/Worn) (mm)	1000/906	22	No. of wagons per train	58
10	Height of C.B.C. from R.L. (mm)	1105	23	Brake System	Air Brake
11	C.G. from R.L. (empty) (m)	1.016	24	Coupler	C.B.C.
12	C.G. from R.L. (loaded) (m)	1.974	25	Bearing	CTRB
13	Floor area (Sq.M)	28.87	26	Maximum Speed (Loaded)/ Empty	75 kmph /80 kmph



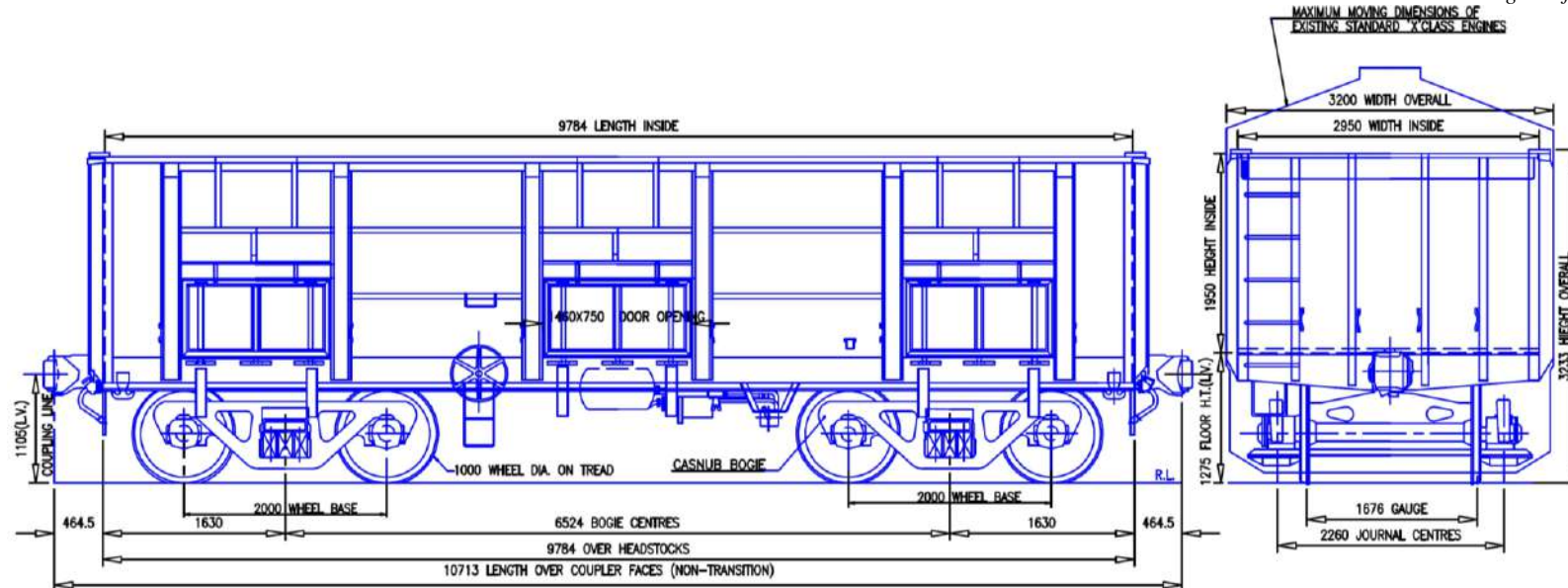


FIG. 1.2 BOXNCR WAGON (RDSO Drg. No. WD- 80007/ S-2)

**INTRODUCTION:** - The wagon is a variant of BOXN wagon with its body in IRS M-44 steel. It's under frame is however made of mild steel. This has been done to provide better corrosion resistance to wagon body. All parameters of this wagon are same as that of BOXN wagon.

**STANDARD FEATURES OF 'BOXNCR' WAGON**

S.No	PARTICULARS	Parameter	S.No	PARTICULARS	Parameter
1	Length over head stock (mm)	9784	14	Cubic Capacity (Cu.M)	56.29
2	Length over couplers (mm)	10713	15	Maximum axle load (tonne)	20.32
3	Length inside (mm)	9784	16	Tare Weight (tonne)	23.2
4	Width inside/Width Overall (mm)	2950/3200	17	Pay load (tonne)	58.08
5	Height inside/Height (max.) from R.L.	1950/3233	18	Gross load (Pay+Tare) (tonne)	81.28
6	Bogie centers (mm)	6524	19	Ratio gross load/Tare	3.5
7	Journal length × dia. (mm)	144x278	20	Ratio (Pay load to tare)	2.5
8	Journal centers (mm)	2260	21	Track Loading density (tonnes/meter)	7.59
9	Wheel dia. on tread (New/Worn) (mm)	1000/906	22	No. of wagons per train	58
10	Height of C.B.C. from R.L. (mm)	1105	23	Brake System	Air Brake
11	C.G. from R.L. (empty) (m)	1.016	24	Coupler	C.B.C.
12	C.G. from R.L. (loaded) (m)	1.974	25	Bearing	CTRB
13	Floor area (Sq.M)	28.87	26	Maximum Speed (Loaded)/ Empty	75 kmph / 80 kmph

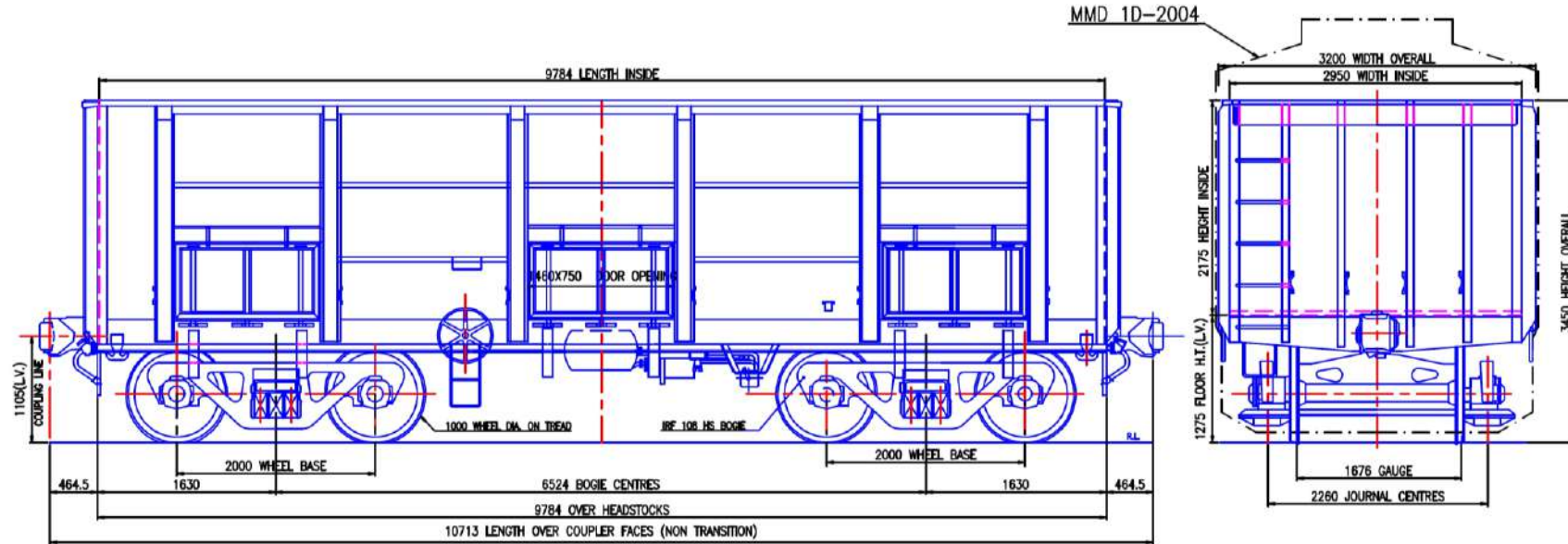


FIG.1.3 BOXNHA WAGON (RDSO Drg. No. WD- 98015 - S- 02)

**INTRODUCTION:** - This wagon has been designed for transportation of coal to axle load of 22.1t. It has higher sidewalls compared to BOXN wagon.

**STANDARD FEATURES OF ‘BOXNHA’ WAGON**

S.No	PARTICULARS	Parameter	S.No	PARTICULARS	Parameter
1	Length over head stock (mm)	9784	14	Cubic Capacity (Cu.M)	62.8
2	Length over couplers (mm)	10713	15	Maximum axle load (tonne)	22.1
3	Length inside (mm)	9784	16	Tare Weight (tonne)	23.17
4	Width inside/Width Overall (mm)	2950/3200	17	Pay load (tonne)	65.23
5	Height inside/Height(max.) from RL.	2175/3450	18	Gross load (Pay+Tare) (tonne)	88.4
6	Bogie centers (mm)	6524	19	Ratio gross load/Tare	3.82
7	Journal length × dia. (mm)	144x278	20	Ratio (Pay load to tare)	2.82
8	Journal centers (mm)	2260	21	Track Loading density (tonnes/meter)	8.25
9	Wheel dia. on tread (New/Worn) (mm)	1000/906	22	No. of wagons per train	58
10	Height of C.B.C. from R.L. (mm)	1105	23	Brake System	Air Brake
11	C.G. from R.L. (empty) (m)	-	24	Coupler	C.B.C.
12	C.G. from R.L. (loaded) (m)	-	25	Bearing	CTRB
13	Floor area (Sq.M)	28.87	26	Maximum Speed (Loaded)/ Empty	75 kmph / 80 kmph

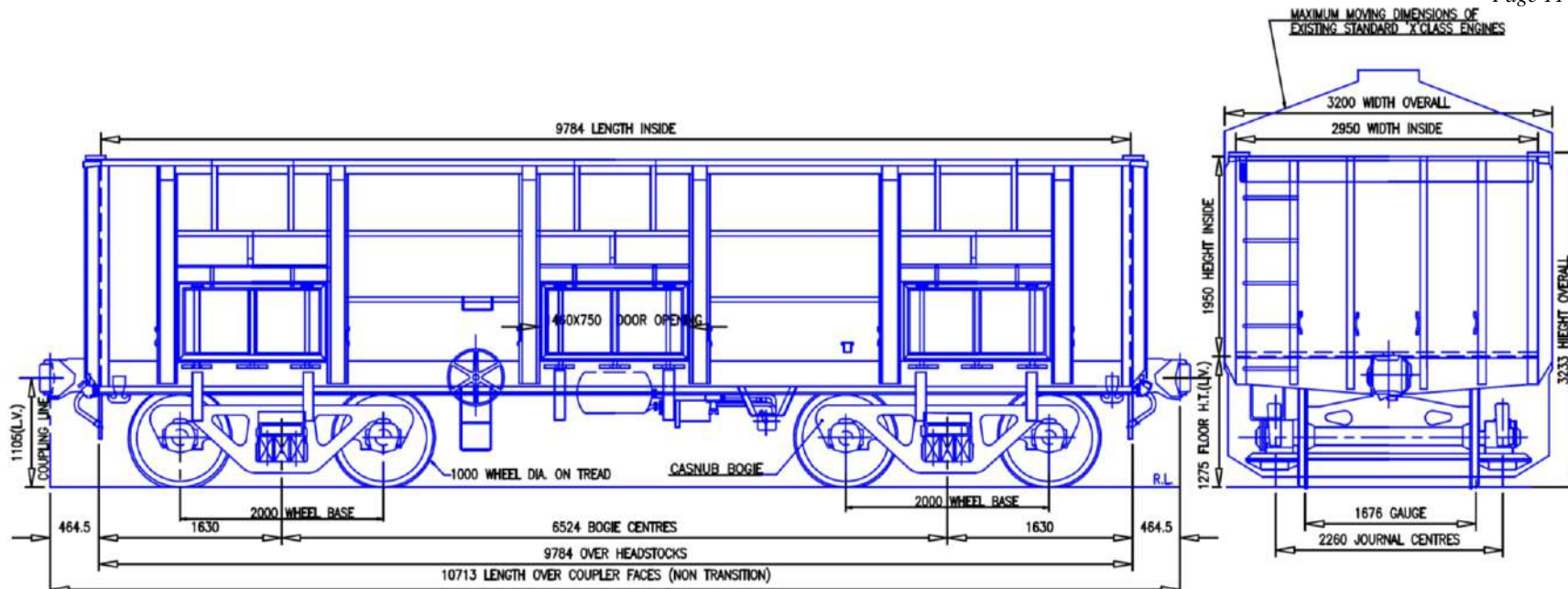


FIG. 1.4 BOXNHS WAGON (RDSO Drg. No. WD – 80007/S- 2)

**INTRODUCTION:** - The wagon is variant of BOXN wagon with operating speed of 100 kmph in empty and 100 kmph in loaded condition. In this wagon high speed bogies have been provided. The other parameters of this wagon are same as of BOXN wagon.

**STANDARD FEATURES OF ‘BOXNHS’ WAGON**

S.No	PARTICULARS	Parameter	S.No	PARTICULARS	Parameter
1	Length over head stock (mm)	9784	14	Cubic Capacity (Cu.M)	56.29
2	Length over couplers (mm)	10713	15	Maximum axle load (tonne)	20.32
3	Length inside (mm)	9784	16	Tare Weight (tonne)	23.2
4	Width inside/Width Overall (mm)	2950/3200	17	Pay load (tonne)	58.08
5	Height inside/Height (max.) from R.L.	1950/3233	18	Gross load (Pay+Tare) (tonne)	81.28
6	Bogie centers (mm)	6524	19	Ratio gross load/Tare	3.5
7	Journal length × dia. (mm)	144x278	20	Ratio (Pay load to tare)	2.5
8	Journal centers (mm)	2260	21	Track Loading density (tonnes/meter)	7.59
9	Wheel dia. on tread (New/Worn) (mm)	1000/906	22	No. of wagons per train	58
10	Height of C.B.C. from R.L. (mm)	1105	23	Brake System	Air Brake
11	C.G. from R.L. (empty) (m)	1.016	24	Coupler	C.B.C.
12	C.G. from R.L. (loaded) (m)	1.974	25	Bearing	CTRB
13	Floor area (Sq.M)	28.87	26	Maximum Speed (Loaded)/ Empty	100 kmph / 100 kmph

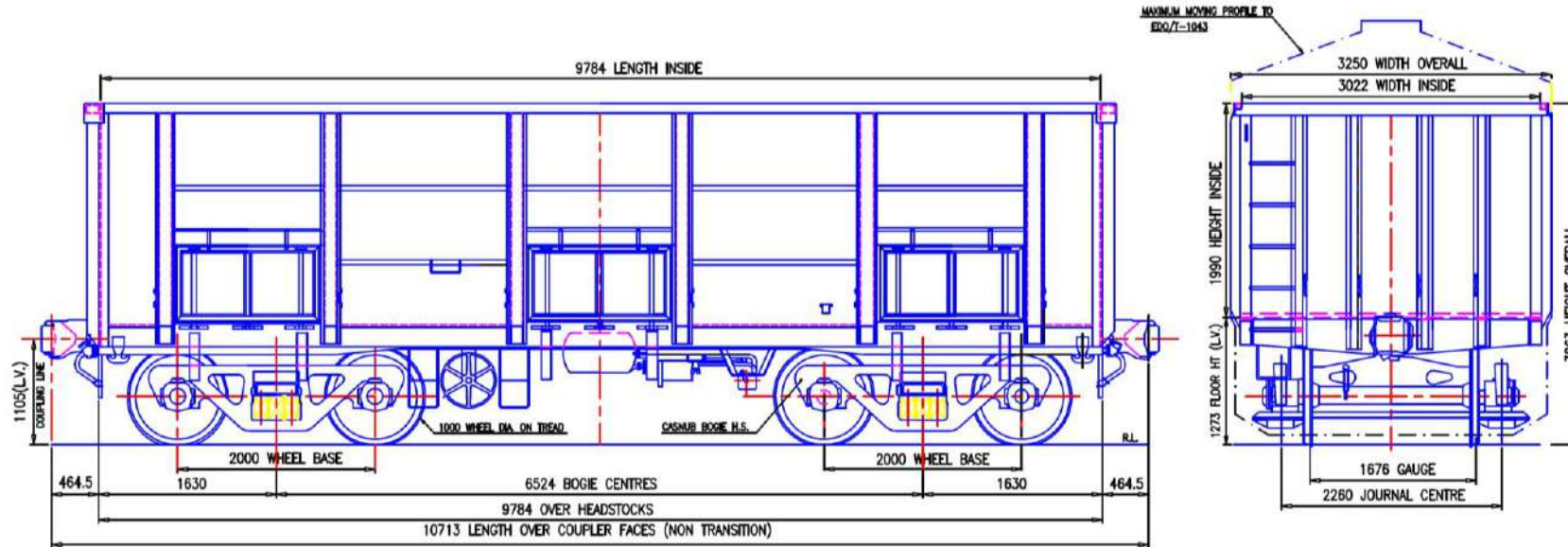


FIG. 1.5 BOXN (LW) WAGON (RDSO Drg. No. WD –88088- S - 02)

**INTRODUCTION:** - To meet the requirement of higher pay to tare ratio, this bogie open wagon was designed in 1988. Cold Rolled Formed (CRF) sections and stainless steel/carton steel are used in design to reduce the tare weight of the wagon.

**STANDARD FEATURES OF 'BOXN (LW)' WAGON**

S.No	PARTICULARS	Parameter	S.No	PARTICULARS	Parameter
1	Length over head stock ( mm)	9784	14	Cubic Capacity (Cu.M)	61.09
2	Length over couplers ( mm)	10713	15	Maximum axle load (tonne)	20.32
3	Length inside ( mm)	9784	16	Tare Weight (tonne)	18.26
4	Width inside/Width Overall ( mm)	3022/3250	17	Pay load (tonne)	63.02
5	Height inside/Height (max.) from R.L.	2066/3341	18	Gross load (Pay+Tare) (tonne)	81.28
6	Bogie centers ( mm)	6524	19	Ratio gross load/Tare	4.45
7	Journal length × dia. ( mm)	144x278	20	Ratio (Pay load to tare)	3.45
8	Journal centers ( mm)	2260	21	Track Loading density (tonnes/meter)	7.59
9	Wheel dia. on tread (New/Worn) ( mm)	1000/906	22	No. of wagons per train	58
10	Height of C.B.C. from R.L. ( mm)	1105	23	Brake System	Air Brake
11	C.G. from R.L. (empty) ( m)	-	24	Coupler	C.B.C.
12	C.G. from R.L. (loaded) ( m)	-	25	Bearing	CTRB
13	Floor area (Sq.M)	29.57	26	Maximum Speed (Loaded)/ Empty	100 kmph / 100 kmph

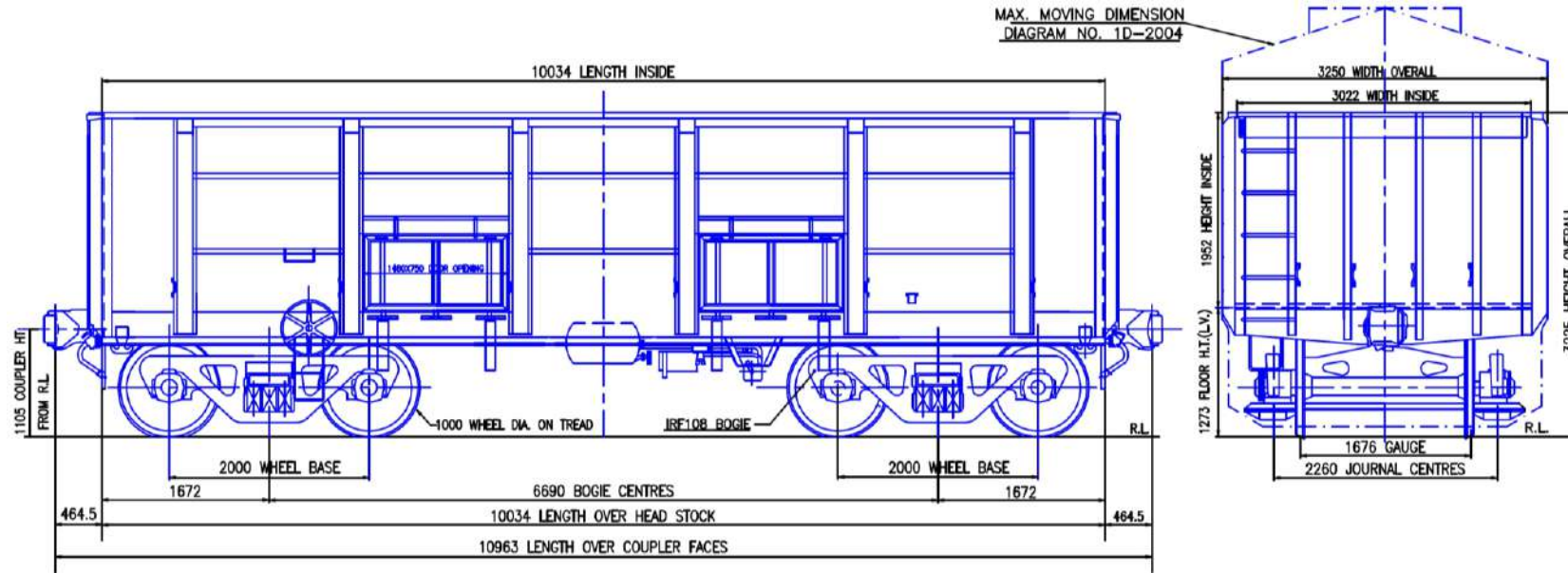


FIG.1.6 BOXNHL WAGON (RDSO Drg. No. WD –05086- S - 02)

**INTRODUCTION:** - This bogie open wagon was designed at 22.9t axle load and 250mm longer than BOXNHS wagon. The wagon is manufactured by using stainless steel and cold rolled sections.

**STANDARD FEATURES OF ‘BOXNHL’ WAGON**

S.No	PARTICULARS	Parameter	S.No	PARTICULARS	Parameter
1	Length over head stock (mm)	10034	14	Cubic Capacity (Cu.M)	61.05
2	Length over couplers (mm)	10963	15	Maximum axle load (tonne)	22.9
3	Length inside (mm)	10034	16	Tare Weight (tonne)	20.6
4	Width inside/Width Overall (mm)	3022/3250	17	Pay load (tonne)	71.0
5	Height inside/Height (max.) from R.L.	2028/3301	18	Gross load (Pay+Tare) (tonne)	91.6
6	Bogie centers (mm)	6690	19	Ratio gross load/Tare	4.45
7	Journal length × dia. (mm)	144x278	20	Ratio (Pay load to tare)	3.45
8	Journal centers (mm)	2260	21	Track Loading density (tonnes/meter)	8.35
9	Wheel dia. on tread (New/Worn) (mm)	1000/906	22	No. of wagons per train	58
10	Height of C.B.C. from R.L. (mm)	1105	23	Brake System	Air Brake
11	C.G. from R.L. (empty) (m)	-	24	Coupler	C.B.C.
12	C.G. from R.L. (loaded) (m)	-	25	Bearing	CTRB
13	Floor area (Sq.M)	30.32	26	Maximum Speed (Loaded)/ Empty	75 kmph / 100 kmph

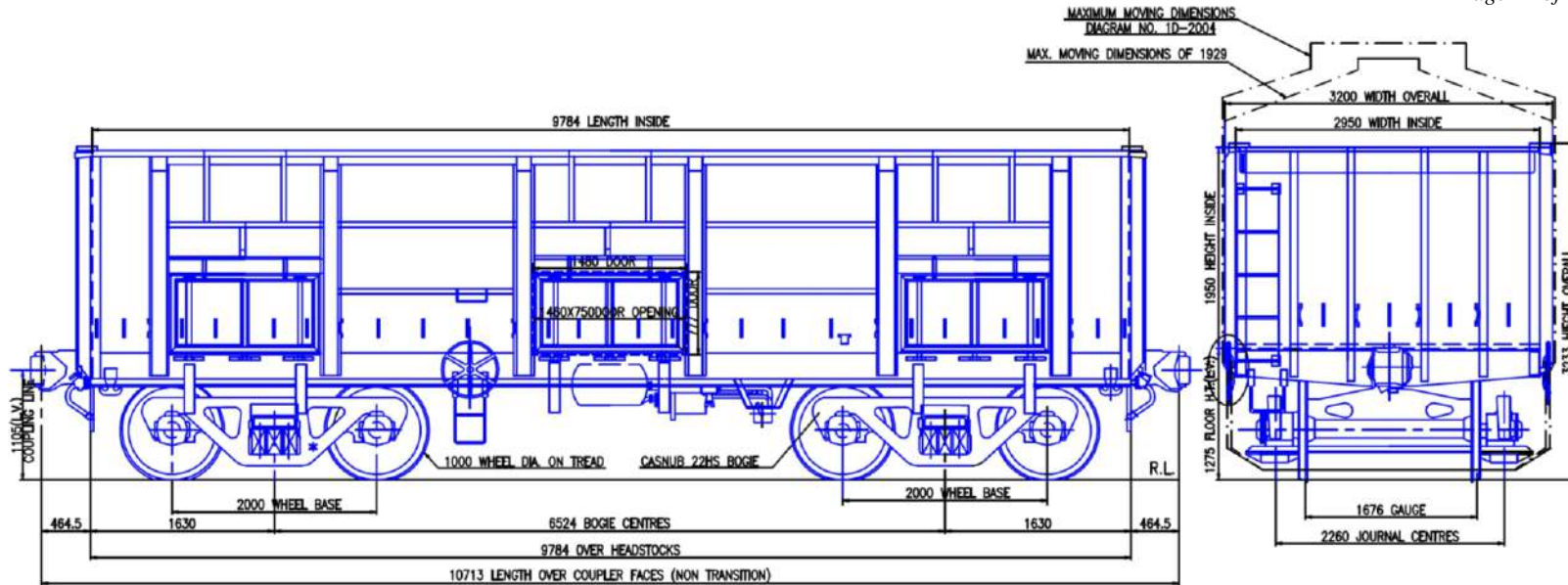


FIG. 1.7 BOXNEL WAGON (RDSO Drg. No. WD -06083/ S - 01)

**INTRODUCTION:** - This wagon has been designed for transportation of iron ores, coal etc. BOXNEL wagons fitted with Casnub-22NLC bogies with a maximum axle load 25 t., non-transition center buffer couplers and single-pipe graduated release air brake system.

**STANDARD FEATURES OF 'BOXNEL' WAGON**

S.No	PARTICULARS	Parameter	S.No	PARTICULARS	Parameter
1	Length over head stock (mm)	9784	14	Cubic Capacity (Cu.M)	56.29
2	Length over couplers (mm)	10713	15	Maximum axle load (tonne)	25
3	Length inside (mm)	9784	16	Tare Weight (tonne)	23.1
4	Width inside/Width Overall (mm)	2950/3200	17	Pay load (tonne)	76.9
5	Height inside/Height(max.) from R.L.	1950/3233	18	Gross load (Pay+Tare) (tonne)	100
6	Bogie centers (mm)	6524	19	Ratio gross load/Tare	4.33
7	Journal length × dia. (mm)	144x278	20	Ratio (Pay load to tare)	3.33
8	Journal centers (mm)	2260	21	Track Loading density (tonnes/meter)	9.33
9	Wheel dia. on tread (New/Worn) (mm)	1000/906	22	No. of wagons per train	58
10	Height of C.B.C. from R.L. (mm)	1105	23	Brake System	Air Brake
11	C.G. from R.L. (empty) (m)	1.016	24	Coupler	C.B.C.
12	C.G. from R.L. (loaded) (m)	1.737	25	Bearing	CTRB
13	Floor area (Sq.M)	28.87	26	Maximum Speed (Loaded)/ Empty	45+5 kmph / 60+5 kmph

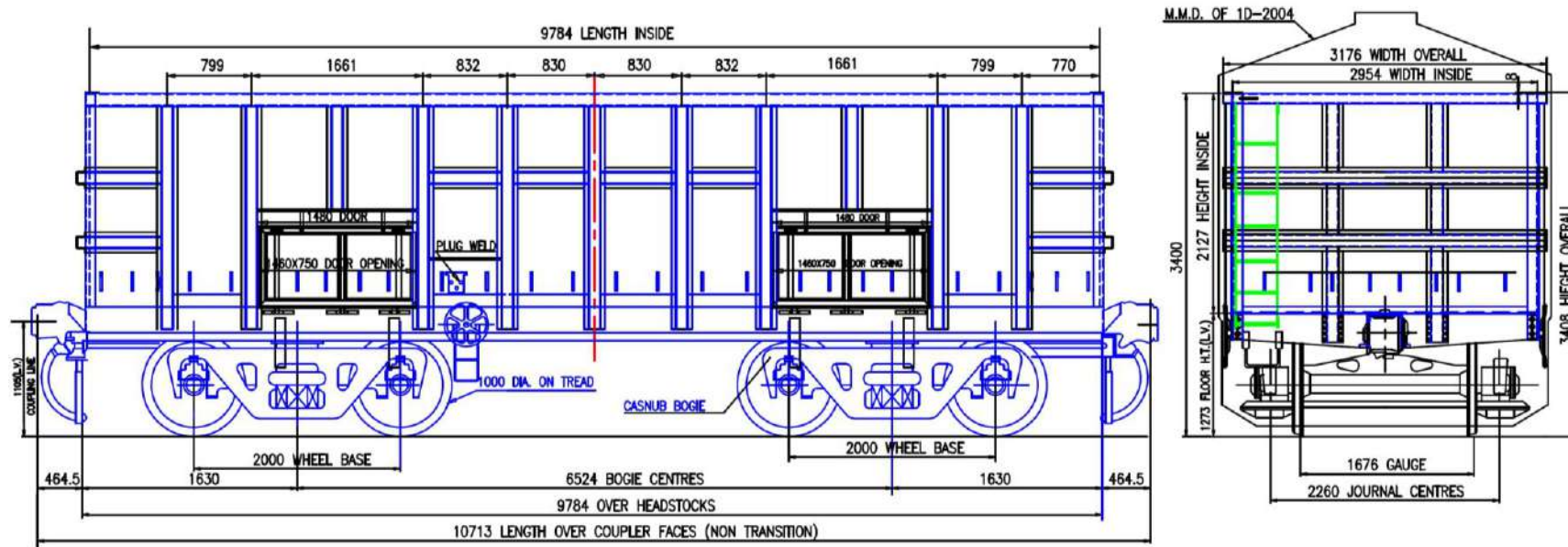


FIG. 1.8 BOXNR WAGON (RDSO Drg. No. WD –07001- S - 02)

**INTRODUCTION:** - This wagon has been designed for transportation of iron ores, coal etc. BOXNR wagons either fitted with Casnub-22W (without Elastomeric pads) or Casnub-22W (with Elastomeric pads) bogies with a maximum axle load 22.9 t., non-transition center buffer couplers and single-pipe graduated release air brake system.

**STANDARD FEATURES OF ‘BOXNR’ WAGON**

S.No	PARTICULARS	Parameter	S.No	PARTICULARS	Parameter
1	Length over head stock (mm)	9784	14	Cubic Capacity (Cu.M)	61.47
2	Length over couplers (mm)	10713	15	Maximum axle load (tonne)	22.9
3	Length inside (mm)	9784	16	Tare Weight (tonne)	21.2
4	Width inside/Width Overall (mm)	2954/3176	17	Pay load (tonne)	70.04
5	Height inside/Height(max.) from RL.	2127/3408	18	Gross load (Pay+Tare) (tonne)	91.6
6	Bogie centers (mm)	6524	19	Ratio gross load/Tare	4.32
7	Journal length × dia. (mm)	144x278	20	Ratio (Pay load to tare)	3.32
8	Journal centers (mm)	2260	21	Track Loading density (tonnes/meter)	8.55
9	Wheel dia. on tread (New/Worn) (mm)	1000/906	22	No. of wagons per train	58
10	Height of C.B.C. from R.L. (mm)	1105	23	Brake System	Air Brake
11	C.G. from R.L. (empty) (m)	1.027	24	Coupler	C.B.C.
12	C.G. from R.L. (loaded) (m)	2.033	25	Bearing	CTRB
13	Floor area (Sq.M)	28.90	26	Maximum Speed (Loaded)/ Empty	60 kmph / 80 kmph

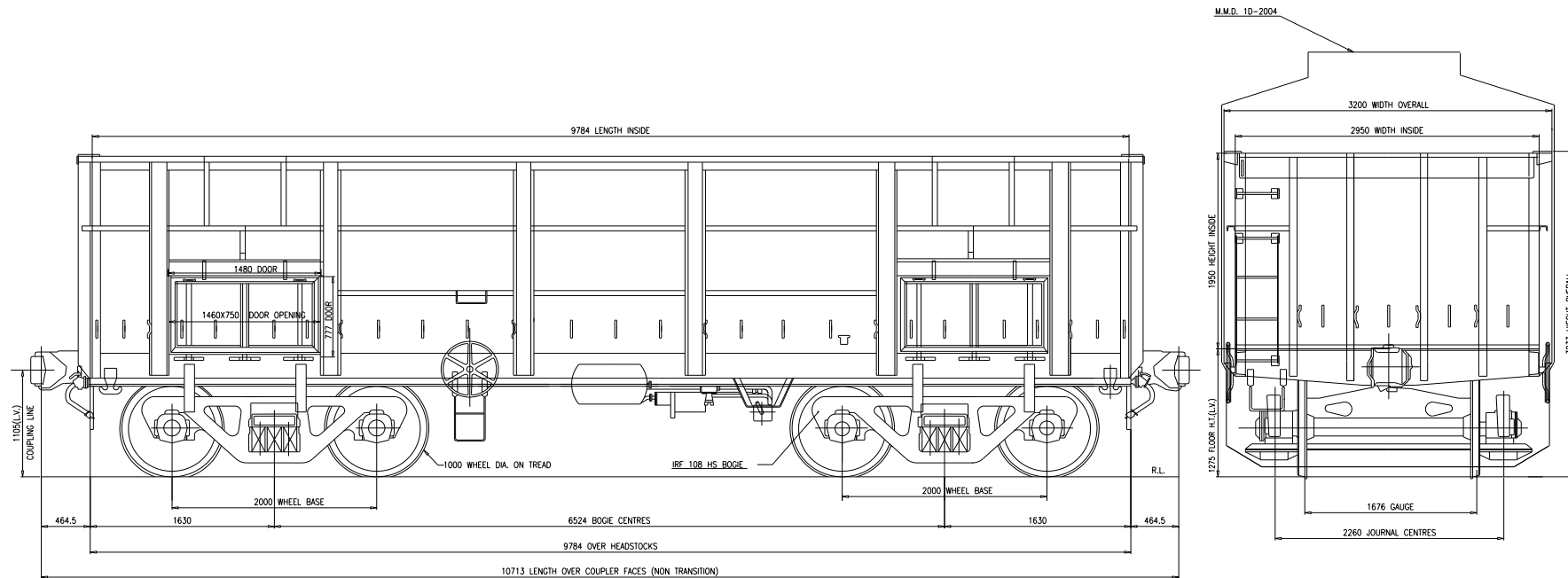


FIG. 1.9

**STANDARD FEATURES OF BOXNHAM WAGON**

S. No.	PARTICULARS	Parameter	S. No.	PARTICULARS	Parameter
1	Length over Hd. Stock	9784 mm	11	Pay load	68.18 t
2	Length over buffer/couplers	10713 mm	12	Ratio pay load /tare	2.95
3	Length inside	9784 mm	13	Gross load	91.28 t
4	Width inside/overall	2950/3200 mm	14	No. of wagons per rake	58
5	Height inside/from rail	1950/3233 mm	15	Throughput per rake	3954 t
6	Bogie centres	6524 mm	16	Loading density	8.52 t/m
7	Journal centres	2260 mm	17	Cubic capacity	56.29 m <sup>3</sup>
8	Wheel dia. On tread	1000/906 mm	18	Speed (empty/ loaded)	100/75
9	Nominal max. axle load	22.82 t	19	Type of coupler	CBC
10	Tare	23.1 t	20	Type of bearing	CTRB



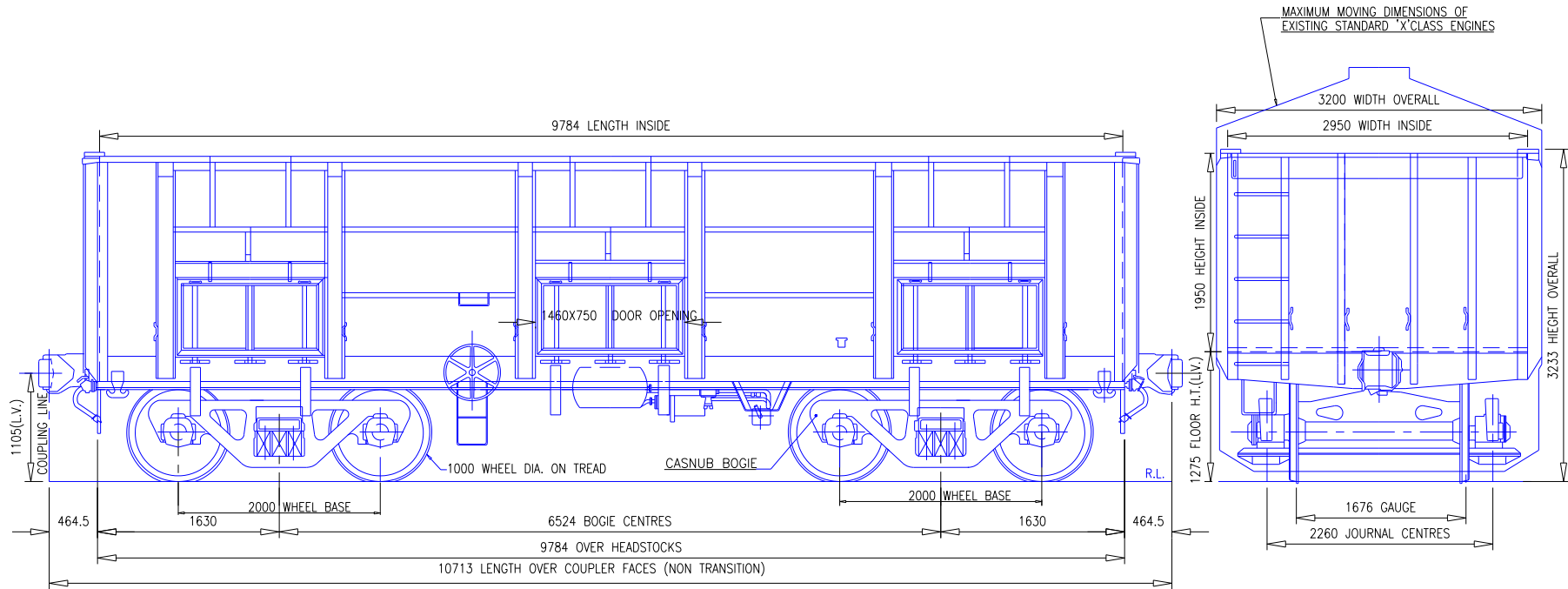


FIG. 1.10

**STANDARD FEATURES OF BOXN/BOXNHS WAGON**

S. No.	PARTICULARS	Parameter	S. No.	PARTICULARS	Parameter
1	Length over Hd. Stock	9784 mm	11	Pay load	58.18 t
2	Length over buffer/couplers	10713 mm	12	Ratio pay load /tare	2.52
3	Length inside	9784 mm	13	Gross load	81.28 t
4	Width inside/overall	2950/3200 mm	14	No. of wagons per rake	58
5	Height inside/from rail	1950/3233 mm	15	Throughput per rake	3374 t
6	Bogie centres	6524 mm	16	Loading density	7.59 t/m
7	Journal centres	2260 mm	17	Cubic capacity	56.29 m <sup>3</sup>
8	Wheel dia. On tread	1000 mm	18	Speed (empty/ loaded)	80/75 BOXN 100/100 BOXNHS
9	Nominal max. axle load	20.32 t	19	Type of coupler	CBC
10	Tare	23.1 t	20	Type of bearing	CTRB

**STANDARD FEATURES OF BOXNHL (MBS) WAGON**

<b>S.No.</b>	<b>PARTICULARS</b>	<b>Parameter</b>	<b>S.No.</b>	<b>PARTICULARS</b>	<b>Parameter</b>
1	Length over Hd. Stock	10034 mm	11	Pay load	71.08 t
2	Length over buffer/couplers	10963 mm	12	Ratio pay load /tare	3.46
3	Length inside	10034 mm	13	Gross load	91.6 t
4	Width inside/overall	3022/3250 mm	14	No. of wagons per rake	58
5	Height inside/from rail	2028/3301 mm	15	Throughput per rake	4123 t
6	Bogie centres	6690 mm	16	Loading density	8.35 t/m
7	Journal centres	2260 mm	17	Cubic capacity	61.50 m <sup>3</sup>
8	Wheel dia. On tread	1000 mm	18	Speed (empty/ loaded)	100/75 Kmph
9	Nominal max. axle load	22.9 t	19	Type of coupler	CBC
10	Tare	20.52 t	20	Type of bearing	CTRB

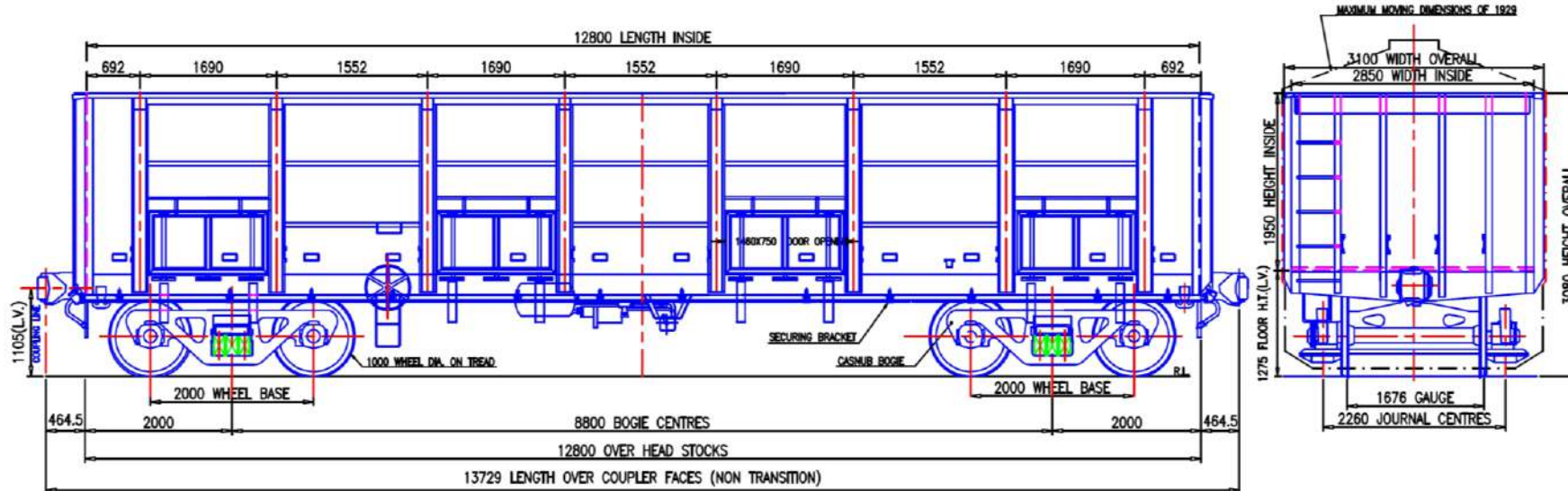


FIG. 1.11 BOST WAGON (RDSO Drg. No. WD - 00012 - S- 01)

**INTRODUCTION:-**This bogie open wagon was designed for transportation of coal as well as steel products. The under frame has been strengthened during the design to sustain point loading of steel consignment. The payload remains the same as BOX N wagon.

**STANDARD FEATURES OF ‘BOST’ WAGON**

S.No	PARTICULARS	Parameter	S.No	PARTICULARS	Parameter
1	Length over head stock ( mm)	12800	14	Cubic Capacity (Cu.M)	65.79
2	Length over couplers ( mm)	13729	15	Maximum axle load (tonne)	20.32
3	Length inside ( mm)	12800	16	Tare Weight (tonne)	25.5
4	Width inside/Width Overall ( mm)	2850/3100	17	Pay load (tonne)	55.78
5	Height inside/Height (max.) from R.L.	1950/3080	18	Gross load (Pay+Tare) (tonne)	81..28
6	Bogie centers ( mm)	8800	19	Ratio gross load/Tare	3.19
7	Journal length × dia. ( mm)	144x278	20	Ratio (Pay load to tare)	2.19
8	Journal centers ( mm)	2260	21	Track Loading density (tonnes/meter)	5.92
9	Wheel dia. on tread (New/Worn) ( mm)	1000/906	22	No. of wagons per train	45
10	Height of C.B.C. from R.L. ( mm)	1105	23	Brake System	Air Brake
11	C.G. from R.L. (empty) ( m)	1.036	24	Coupler	C.B.C.
12	C.G. from R.L. (loaded) ( m)	1.792	25	Bearing	CTRB
13	Floor area (Sq.M)	36.45	26	Maximum Speed (Loaded)/ Empty	75 kmph/ 80 kmph

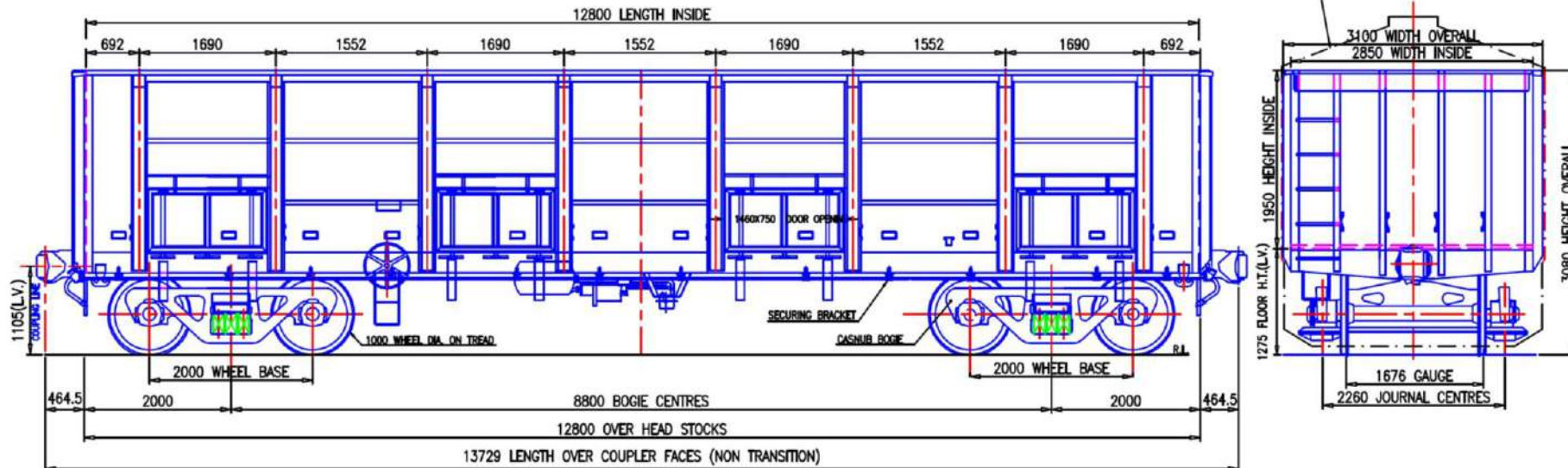


FIG. 1.12 BOSTHS WAGON (RDSO Drg. No. WD - 00012 - S- 01)

**INTRODUCTION:** - This wagon is variant of BOST wagon with high-speed casnub bogie.

**STANDARD FEATURES OF ‘BOSTHS’ WAGON**

S.No	PARTICULARS	Parameter	S.No	PARTICULARS	Parameter
1	Length over head stock (mm)	12800	14	Cubic Capacity (Cu.M)	65.79
2	Length over couplers (mm)	13729	15	Maximum axle load (tonne)	20.32
3	Length inside (mm)	12800	16	Tare Weight (tonne)	25.5
4	Width inside/Width Overall (mm)	2850/3100	17	Pay load (tonne)	55.78
5	Height inside/Height (max.) from R.L.	1950/3080	18	Gross load (Pay+Tare) (tonne)	81.28
6	Bogie centers (mm)	8800	19	Ratio gross load/Tare	3.19
7	Journal length × dia. (mm)	144x278	20	Ratio (Pay load to tare)	2.19
8	Journal centers (mm)	2260	21	Track Loading density (tonnes/meter)	5.92
9	Wheel dia. on tread (New/Worn) (mm)	1000/906	22	No. of wagons per train	45
10	Height of C.B.C. from R.L. (mm)	1105	23	Brake System	Air Brake
11	C.G. from R.L. (empty) (m)	1.036	24	Coupler	C.B.C.
12	C.G. from R.L. (loaded) (m)	1.792	25	Bearing	CTRB.
13	Floor area (Sq.M)	36.45	26	Maximum Speed (Loaded)/ Empty	100 kmph / 100 kmph

**STANDARD FEATURES OF BOSTHSM1 WAGON (CC+6t.+2t.)**

<b>S.No.</b>	<b>PARTICULARS</b>	<b>Parameter</b>	<b>S.No.</b>	<b>PARTICULARS</b>	<b>Parameter</b>
1	Length over Hd. Stock	12800 mm	11	Pay load	63.78 t.
2	Length over buffer/couplers	13729mm	12	Ratio pay load /tare	2.5
3	Length inside	12800 mm	13	Gross load	89.28 t.
4	Width inside/overall	2850/3100 mm	14	No. of wagons per rake	45
5	Height inside/from rail	1805/3080 mm	15	Throughput per rake	2870.1 t.
6	Bogie centres	8800 mm	16	Loading density	6..50 t/m
7	Journal centres	2260 mm	17	Cubic capacity	65.79 m3
8	Wheel dia. On tread	1000 mm	18	Speed (empty/ loaded)	80/60
9	Nominal max. axle load	22.32 t.	19	Type of coupler	CBC
10	Tare	25.5 t.	20	Type of bearing	CTRB

**STANDARD FEATURES OF BOSTHSM2 WAGON (CC+6t.+2t.)**

<b>S.No.</b>	<b>PARTICULARS</b>	<b>Parameter</b>	<b>S.No.</b>	<b>PARTICULARS</b>	<b>Parameter</b>
1	Length over Hd. Stock	12800 mm	11	Pay load	63.78 t.
2	Length over buffer/couplers	13729mm	12	Ratio pay load /tare	2.5
3	Length inside	12800 mm	13	Gross load	89.28 t.
4	Width inside/overall	2850/3100 mm	14	No. of wagons per rake	45
5	Height inside/from rail	1805/3078 mm	15	Throughput per rake	2870.1 t.
6	Bogie centres	8800 mm	16	Loading density	6.50 t/m
7	Journal centres	2260 mm	17	Cubic capacity	65.79 m3
8	Wheel dia. On tread	1000 mm	18	Speed (empty/ loaded)	100/60
9	Nominal max. axle load	22.32 t.	19	Type of coupler	CBC
10	Tare	25.5 t.	20	Type of bearing	CTRB

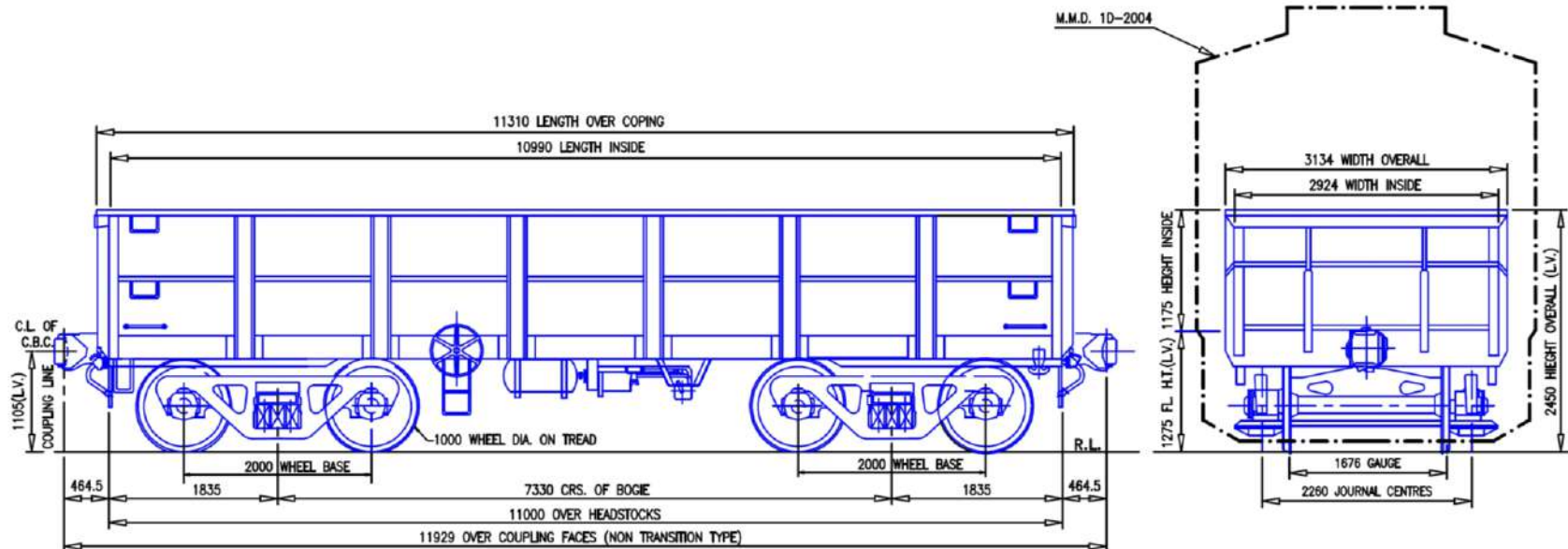
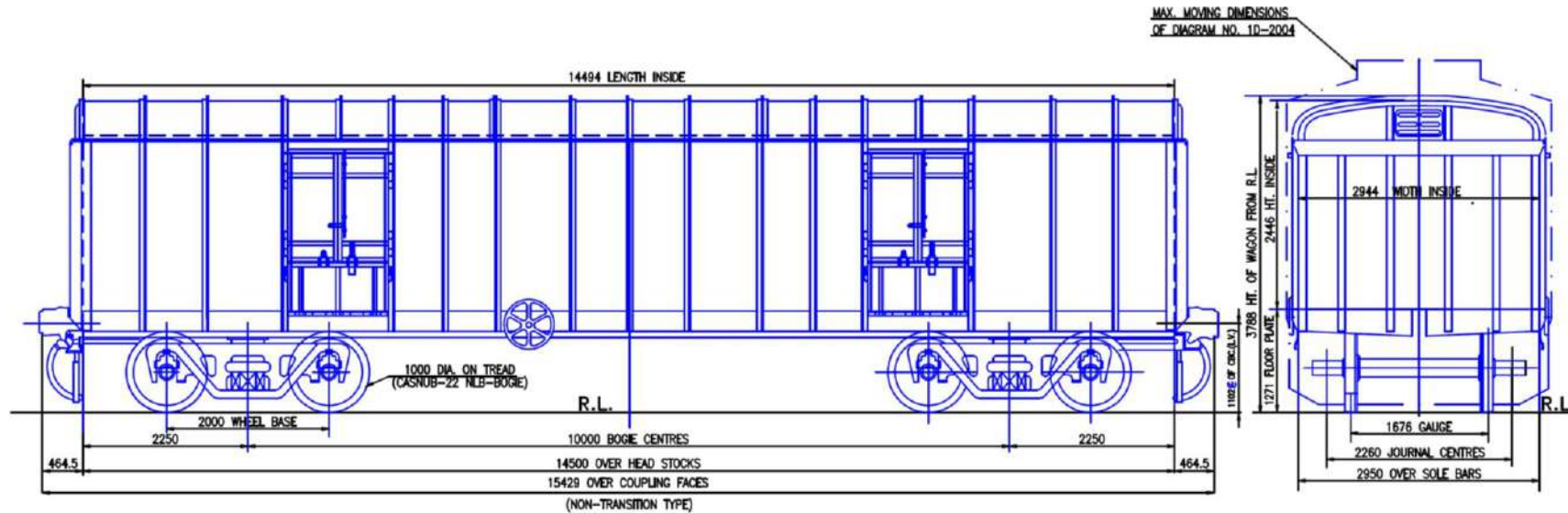


FIG. 1.13 BOYEL WAGON (RDSO Drg. No. WD –06084- S / 01)

**INTRODUCTION:** - This wagon has been designed for transportation of iron ores, coal etc. BOYEL wagons fitted with Casnub-22NLC bogies with a maximum axle load 25 t., nontransition center buffer couplers and single-pipe graduated release air brake system.

**STANDARD FEATURES OF ‘BOYEL’ WAGON**

S.No	PARTICULARS	Parameter	S.No	PARTICULARS	Parameter
1	Length over head stock (mm)	11000	14	Cubic Capacity (Cu.M)	37.8
2	Length over couplers (mm)	11929	15	Maximum axle load (tonne)	25
3	Length inside (mm)	10990	16	Tare Weight (tonne)	20.7
4	Width inside/Width Overall (mm)	2924/3134	17	Pay load (tonne)	79.3
5	Height inside/Height(max.) from R.L.	1175/2450	18	Gross load (Pay+Tare) (tonne)	100
6	Bogie centers (mm)	7330	19	Ratio gross load/Tare	4.83
7	Journal length × dia. (mm)	144x278	20	Ratio (Pay load to tare)	3.83
8	Journal centers (mm)	2260	21	Track Loading density (tonnes/meter)	8.38
9	Wheel dia. on tread (New/Worn) (mm)	1000/906	22	No. of wagons per train	52
10	Height of C.B.C. from R.L. (mm)	1105	23	Brake System	Air Brake
11	C.G. from R.L. (empty) (m)	0.972	24	Coupler	C.B.C.
12	C.G. from R.L. (loaded) (m)	1.613	25	Bearing	CTRB
13	Floor area (Sq.M)	32.13	26	Maximum Speed (Loaded)/ Empty	45+5 kmph / 60+5 kmph



**FIG. 1.14 BCN COVERED WAGON (RDSO Drg. No. WD- 84014 – S- 1)**

**INTRODUCTION:** - This bogie covered wagon designed at 20.32t axle load in 1984. The construction of wagon was purely riveted. The wagon was designed for transportation of bag commodities.

**STANDARD FEATURES OF ‘BCN’ COVERD WAGON**

S.No	PARTICULARS	Parameter	S.No	PARTICULARS	Parameter
1	Length over head stock (mm)	14500	14	Cubic Capacity (Cu.M)	104.00
2	Length over couplers (mm)	15429	15	Maximum axle load (tonne)	20.32
3	Length inside (mm)	14494	16	Tare Weight (tonne)	27.20
4	Width inside/Width Overall (mm)	2944/3100	17	Pay load (tonne)	54.08
5	Height inside/Height (max.) from R.L.	2446/3788	18	Gross load (Pay+Tare) (tonne)	81.28
6	Bogie centers (mm)	10000	19	Ratio gross load/Tare	2.99
7	Journal length × dia. (mm)	RB144.5 Ø	20	Ratio (Pay load to tare)	1.99
8	Journal centers (mm)	2260	21	Track Loading density (tonnes/meter)	5.268
9	Wheel dia. on tread (New/Worn) (mm)	1000/906	22	No. of wagons per train	40
10	Height of C.B.C. from R.L. (mm)	1102	23	Brake System	Air Brake
11	C.G. from R.L. (empty) (m)	1.016	24	Coupler	C.B.C.
12	C.G. from R.L. (loaded) (m)	1.974	25	Bearing	CTRB
13	Floor area (Sq.M)	42.67	26	Maximum Speed (Loaded)/ Empty	75 kmph / 80 kmph

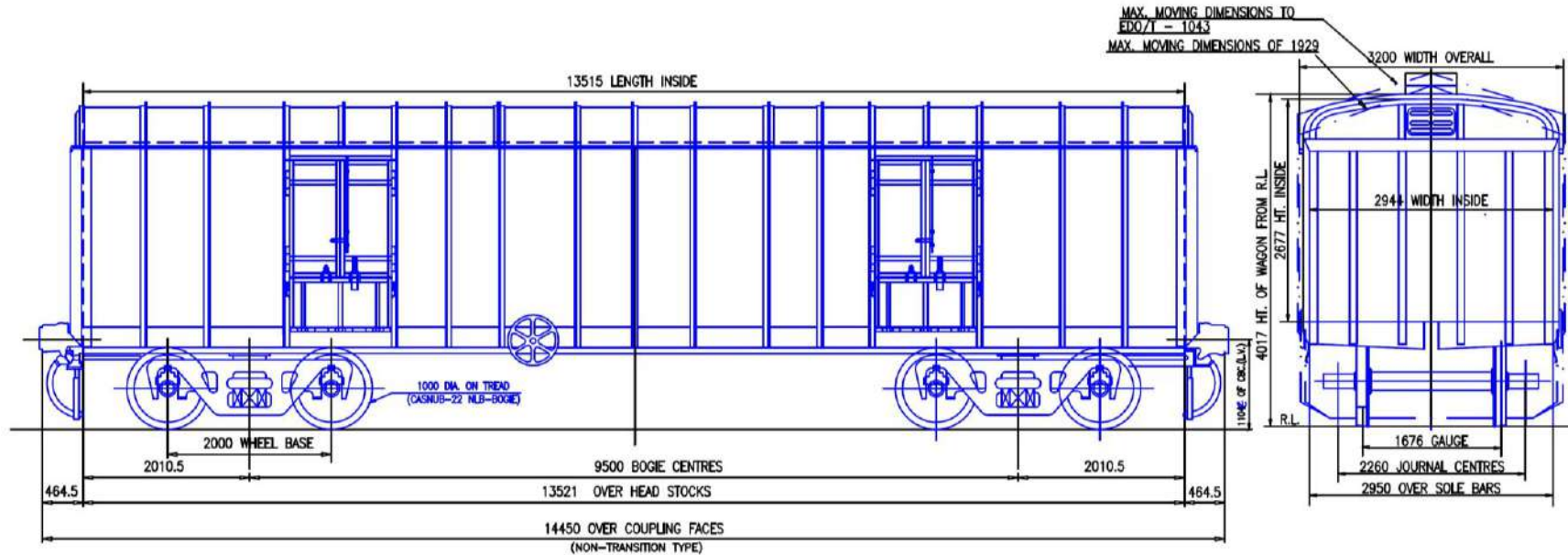


FIG. 1.15 BCNA COVERED WAGON (RDSO Drg. No. WD- 90030 – S- 51)

**INTRODUCTION:** - This wagon is an improved BCN wagon having reduced length and increase height by keeping volumetric capacity same and the wagon was fully welded construction.

**STANDARD FEATURES OF ‘BCNA’ COVERD WAGON**

S.No	PARTICULARS	Parameter	S.No	PARTICULARS	Parameter
1	Length over head stock (mm)	13521	14	Cubic Capacity (Cu.M)	103.40
2	Length over couplers (mm)	14450	15	Maximum axle load (tonne)	20.32
3	Length inside (mm)	13515	16	Tare Weight (tonne)	24.55
4	Width inside/Width Overall (mm)	2944/3200	17	Pay load (tonne)	56.73
5	Height inside/Height (max.) from R.L.	2677/4017	18	Gross load (Pay+Tare) (tonne)	81.28
6	Bogie centers (mm)	9500	19	Ratio gross load/Tare	3.31
7	Journal length × dia. (mm)	RB144.5 Ø	20	Ratio (Pay load to tare)	2.31
8	Journal centers (mm)	2260	21	Track Loading density (tonnes/meter)	5.625
9	Wheel dia. on tread (New/Worn) (mm)	1000/906	22	No. of wagons per train	43
10	Height of C.B.C. from R.L. (mm)	1104	23	Brake System	Air Brake
11	C.G. from R.L. (empty) (m)	1.2395	24	Coupler	C.B.C.
12	C.G. from R.L. (loaded) (m)	1.9915	25	Bearing	CTRB
13	Floor area (Sq.M)	-	26	Maximum Speed (Loaded)/ Empty	75 kmph / 80 kmph



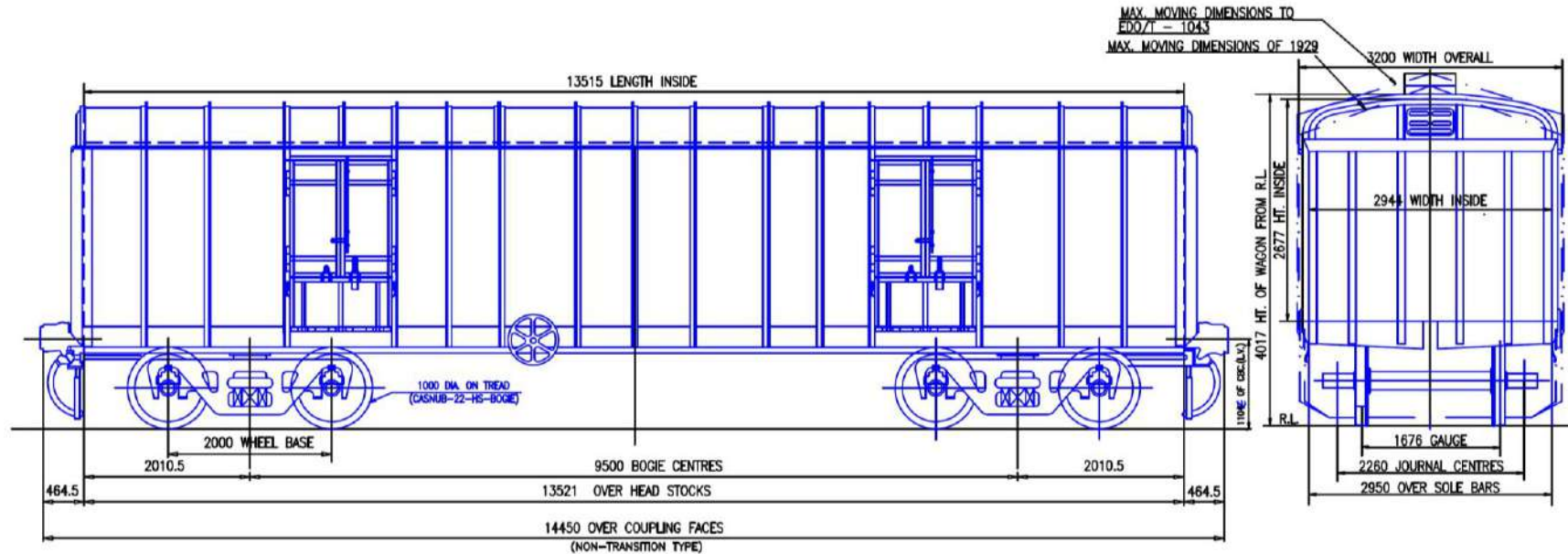


FIG. 1.16 BCNAHS COVERED WAGON (RDSO Drg. No. WD- 90030 – S- 51)

**INTRODUCTION:** - This wagon is variant of BCNA wagon with high speed bogie CASNUB-22HS-BOGIE. The other parameters of this wagon are same as of BCNA wagon.

**STANDARD FEATURES OF ‘BCNAHS’ COVERD WAGON**

S.No	PARTICULARS	Parameter	S.No	PARTICULARS	Parameter
1	Length over head stock (mm)	13521	14	Cubic Capacity (Cu.M)	103.40
2	Length over couplers (mm)	14450	15	Maximum axle load (tonne)	20.32
3	Length inside (mm)	13515	16	Tare Weight (tonne)	24.6
4	Width inside/Width Overall (mm)	2944/3200	17	Pay load (tonne)	56.68
5	Height inside/Height (max.) from R.L.	2677/4017	18	Gross load (Pay+Tare) (tonne)	81.28
6	Bogie centers (mm)	9500	19	Ratio gross load/Tare	3.3
7	Journal length × dia. (mm)	RB144.5 Ø	20	Ratio (Pay load to tare)	2.3
8	Journal centers (mm)	2260	21	Track Loading density (tonnes/meter)	5.625
9	Wheel dia. on tread (New/Worn) (mm)	1000/906	22	No. of wagons per train	43
10	Height of C.B.C. from R.L. (mm)	1104	23	Brake System	Air Brake
11	C.G. from R.L. (empty) (m)	1.2395	24	Coupler	C.B.C.
12	C.G. from R.L. (loaded) (m)	1.9915	25	Bearing	CTRB
13	Floor area (Sq.M)	-	26	Maximum Speed (Loaded)/ Empty	100 kmph / 100 kmph

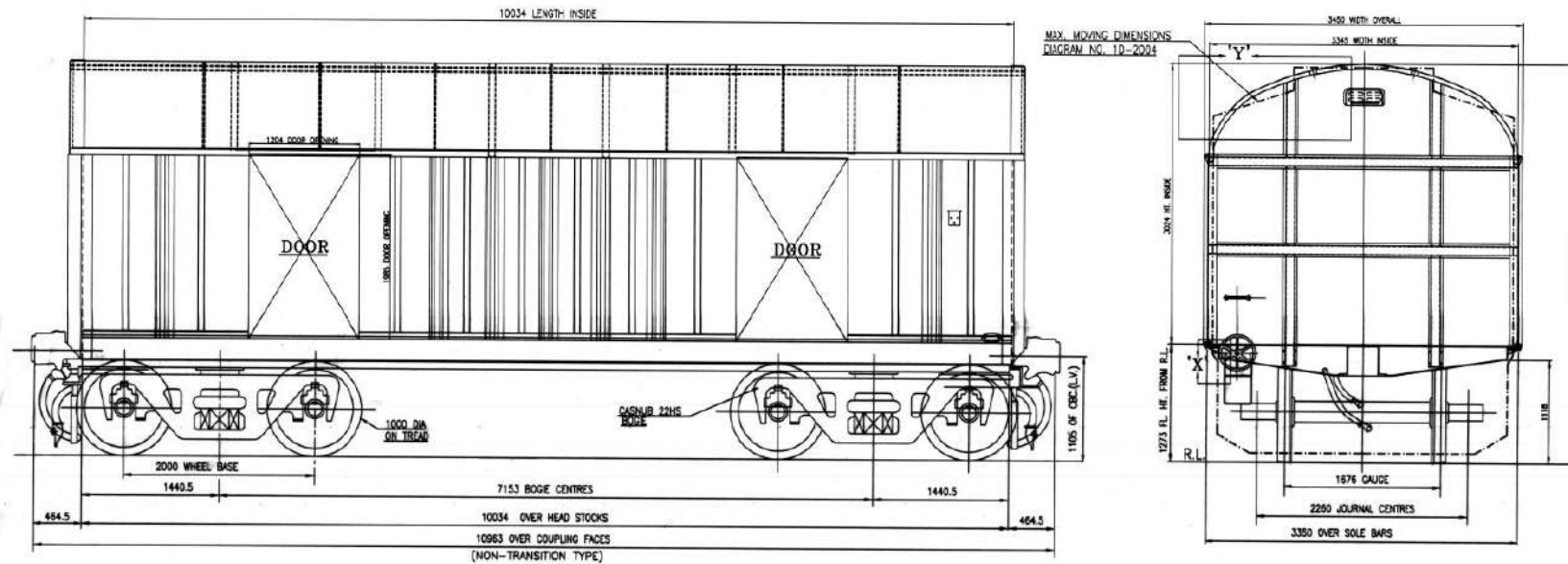


FIG. 1.17 BCNHL COVERED WAGON (RDSO Drg. No. WD- 06076 – S- 02)

**INTRODUCTION:** - This wagon fitted with twin pipe graduated release air brake system, high tensile non transition type CBC and cast steel bogie to STR No. WD-17 CASNUB 22 HS Bogie 92 with latest amendment.

**STANDARD FEATURES OF BCNHL WAGON -DESIGN-D**

S.No.	PARTICULARS	Parameter	S.No.	PARTICULARS	Parameter
1	Length over Hd. Stock	10034 mm	11	Pay load	70.8t.
2	Length over buffer/couplers	10963 mm	12	Ratio pay load /tare	3.4
3	Length inside	10034 mm	13	Gross load	91.6 t.
4	Width inside/overall	3345/3450 mm	14	No. of wagons per rake	58
5	Height inside/from rail	3024/4305mm	15	Throughput per rake	4106 t.
6	Bogie centres	7153 mm	16	Loading density	8.35 t/m
7	Journal centres	2260mm	17	Cubic capacity	92.54 m <sup>3</sup>
8	Wheel dia. On tread	1000mm	18	Speed (empty/ loaded)	100 Kmph
9	Nominal max. axle load	22.9 t.	19	Type of coupler	CBC
10	Tare	20.8t.	20	Type of bearing	CTRB

**STANDARD FEATURES OF BCBFG WAGON (Food Grains) Drg. No.RSD-6337-052**

<b>S.No.</b>	<b>PARTICULARS</b>	<b>Parameter</b>	<b>S.No.</b>	<b>PARTICULARS</b>	<b>Parameter</b>
1	Length over Hd. Stock	11861mm	11	Pay load	60.84 t.
2	Length over buffer/couplers	12790 mm	12	Ratio pay load /tare	2.38
3	Length inside	11770 mm	13	Gross load	87.28 t.
4	Width inside/overall	3140/3250 mm	14	No. of wagons per rake	49
5	Max. Height from rail	4260 mm	15	Throughput per rake	2981 t.
6	Bogie centres	8661 mm	16	Loading density	6.82 t./m
7	Journal centres	2260 mm	17	Cubic capacity	81.76 m <sup>3</sup>
8	Wheel dia. On tread	1000 mm	18	Speed (empty/ loaded)	E-75 & L-75
9	Nominal max. axle load	21.82 t.	19	Type of coupler	CBC
10	Tare	26.44 t.	20	Type of bearing	CTRB

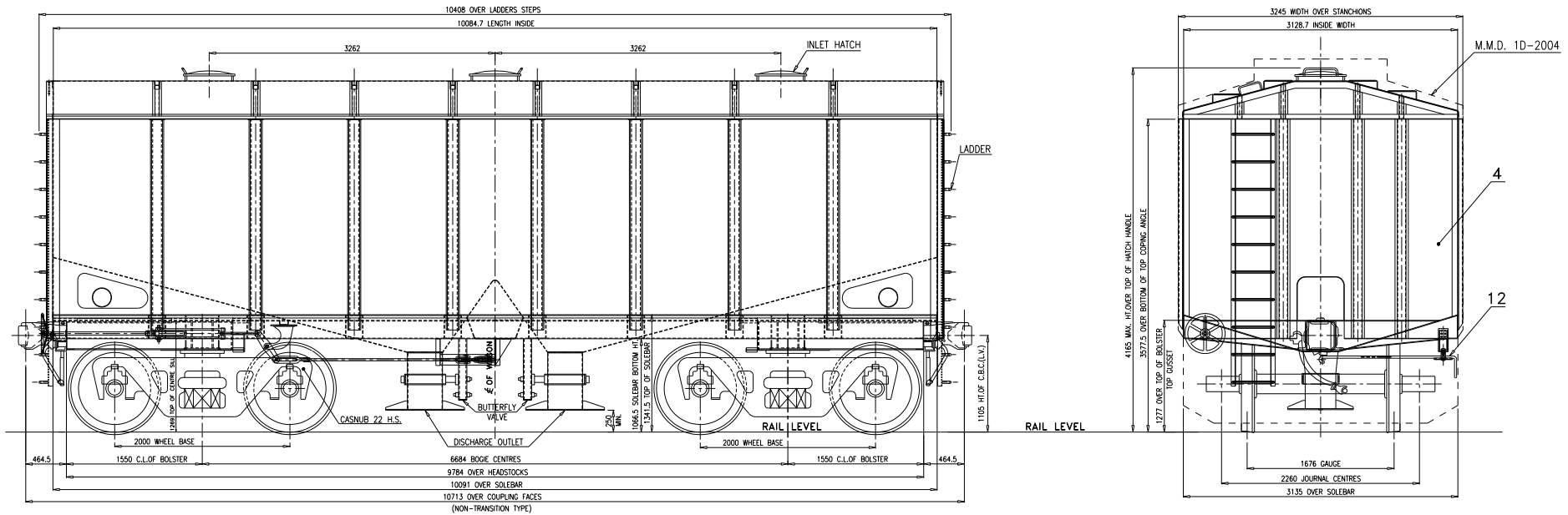


FIG. 1.18

**STANDARD FEATURES OF BCFC WAGON**

S. No.	PARTICULARS	Fly Ash	Cement	S. No.	PARTICULARS	Fly Ash	Cement
1	Length over Hd. Stock	9784mm	9784mm	11	Pay load	49 t.	67.3 t.
2	Length over buffer/couplers	10713 mm	10713 mm	12	Ratio pay load /tare	2.22	3.06
3	Length inside	10084.7 mm	10084.7 mm	13	Gross load	71 t.	89.3 t.
4	Width inside/overall	3128.7/3245 mm	3128.7/3245 mm	14	No. of wagons per rake	58	58
5	Height inside/from rail	4165 mm	4165 mm	15	Throughput per rake	2842 t.	3904 t.
6	Bogie centres	6684 mm	6684 mm	16	Loading density	6.62 t./m	8.335 t./m
7	Journal centres	2260 mm	2260 mm	17	Cubic capacity	72.8 m <sup>3</sup>	72.8 m <sup>3</sup>
8	Wheel dia. On tread	1000 mm	1000 mm	18	Speed (empty/ loaded)	65 Kmph	65 Kmph
9	Nominal max. axle load	17.75 t.	22.32 t.	19	Type of coupler	CBC	CBC
10	Tare	22 t.	22 t.	20	Type of bearing	CTRB	CTRB

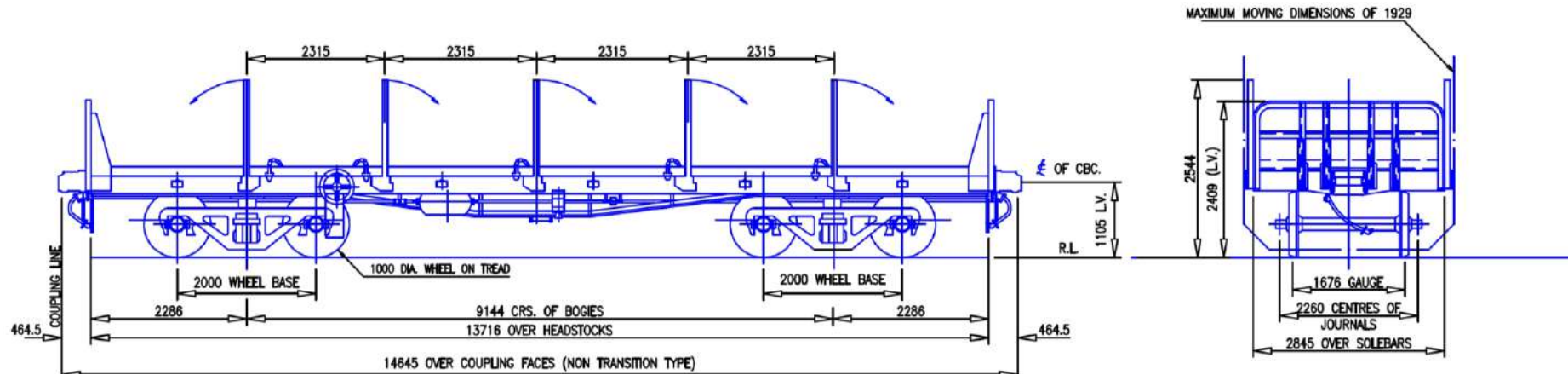


FIG. 1.19 BRN FLAT WAGON (RDSO Drg. No. WD- 84013 – S- 1)

**INTRODUCTION:** - This bogie rail wagon was designed in 1994. The design was improvement of earlier design of BRH wagon. The wagon Design is with air brake and welded construction.

**STANDARD FEATURES OF ‘BRN’ FLAT WAGON**

S.No	PARTICULARS	Parameter	S.No	PARTICULARS	Parameter
1	Length over head stock (mm)	13716	14	Maximum axle load (tonne)	20.32
2	Length over couplers (mm)	14645	15	Tare Weight (tonne)	24.393
3	Length inside (mm)	13716	16	Pay load (tonne)	56.887
4	Width inside/Width Overall (mm)	2845	17	Gross load (Pay+Tare) (tonne)	81.28
5	Height inside/Height (max.) from R.L.	---/ 2544	18	Ratio gross load/Tare	3.33
6	Bogie centers (mm)	9144	19	Ratio (Pay load to tare)	2.33
7	Journal length × dia. (mm)	RB144.5 Ø	20	Track Loading density (tonnes/meter)	5.55
8	Journal centers (mm)	2260	21	No. of wagons per train	42
9	Wheel dia. on tread (New/Worn) (mm)	1000/906	22	Brake System	Air Brake
10	Height of C.B.C. from R.L. (mm)	1105	23	Coupler	C.B.C.
11	C.G. from R.L. (empty) (m)	-	24	Bearing	CTRB
12	C.G. from R.L. (loaded) (m)	-	25	Maximum Speed (Loaded)/ Empty	75 kmph / 80 kmph
13	Floor area (Sq.M)	-			

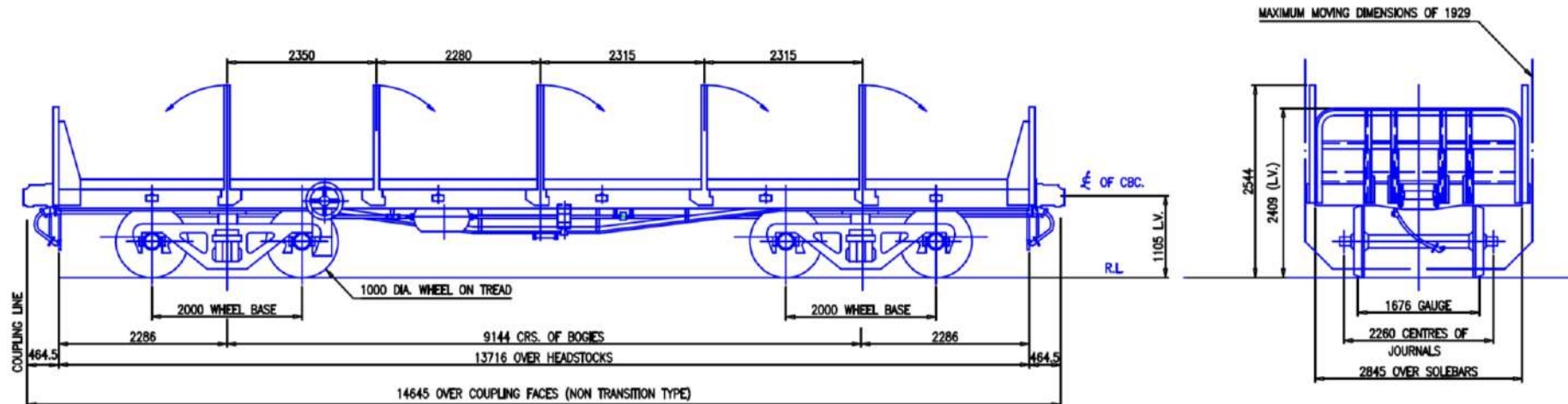


FIG. 1.20 BRNA FLAT WAGON (RDSO Drg. No. WD- 92004 – S- 02)

**INTRODUCTION:** - This bogie rail wagon was designed by improvement of BRN wagon in 1992. The design was riveted cum welded construction. It is higher pay to tare ratio as compared to BRN wagon.

**STANDARD FEATURES OF ‘BRNA’ FLAT WAGON**

S.No	PARTICULARS	Parameter	S.No	PARTICULARS	Parameter
1	Length over head stock (mm)	13716	14	Maximum axle load (tonne)	20.32
2	Length over couplers (mm)	14645	15	Tare Weight (tonne)	23.543
3	Length inside (mm)	13716	16	Pay load (tonne)	57.737
4	Width inside/Width Overall (mm)	2845	17	Gross load (Pay+Tare) (tonne)	81.28
5	Height inside/Height (max.) from R.L. (mm)	2544	18	Ratio gross load/Tare	3.452
6	Bogie centers (mm)	9144	19	Ratio (Pay load to tare)	2.452
7	Journal length × dia. (mm)	RB144.5 Ø	20	Track Loading density (tonnes/meter)	5.55
8	Journal centers (mm)	2260	21	No. of wagons per train	42
9	Wheel dia. on tread (New/Worn) (mm)	1000/906	22	Brake System	Air Brake
10	Height of C.B.C. from R.L. (mm)	1105	23	Coupler	C.B.C.
11	C.G. from R.L. (empty) (m)	-	24	Bearing	CTRB
12	C.G. from R.L. (loaded) (m)	-	25	Maximum Speed (Loaded)/ Empty	75 kmph / 80 kmph
13	Floor area (Sq.M)	-			

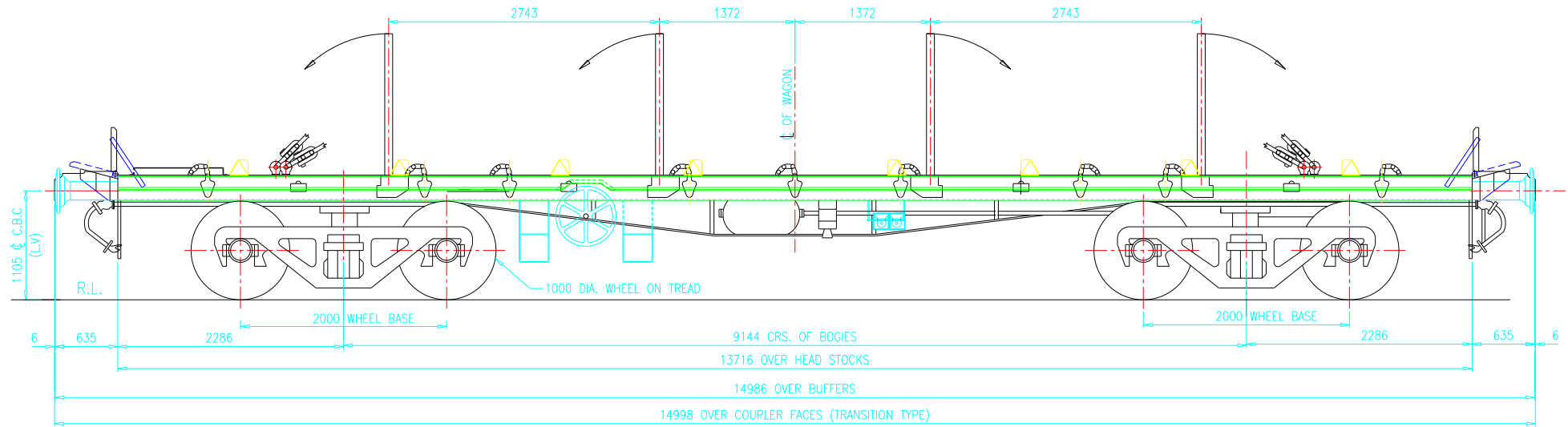


FIG. 1.21

**STANDARD FEATURES OF BRSTN WAGON**

S. No.	PARTICULARS	Parameter	S. No.	PARTICULARS	Parameter
1	Length over Hd. Stock	13716mm	11	Pay load	56.27 t.
2	Length over buffer/couplers	14998 mm	12	Ratio pay load /tare	2.25
3	Length inside	13716 mm	13	Gross load	81.28 t.
4	Width inside/overall	3200mm	14	No. of wagons per rake	41
5	Height inside/from rail	1264 mm	15	Throughput per rake	--
6	Bogie centres	9144 mm	16	Loading density	5.419 t/m.
7	Journal centres	2260 mm	17	Cubic capacity	FLAT WAGON
8	Wheel dia. On tread	1000 mm	18	Speed (empty/ loaded)	80/75 Kmph
9	Nominal max. axle load	20.32 t.	19	Type of coupler	CBC
10	Tare	25.01 t.	20	Type of bearing	CTRB

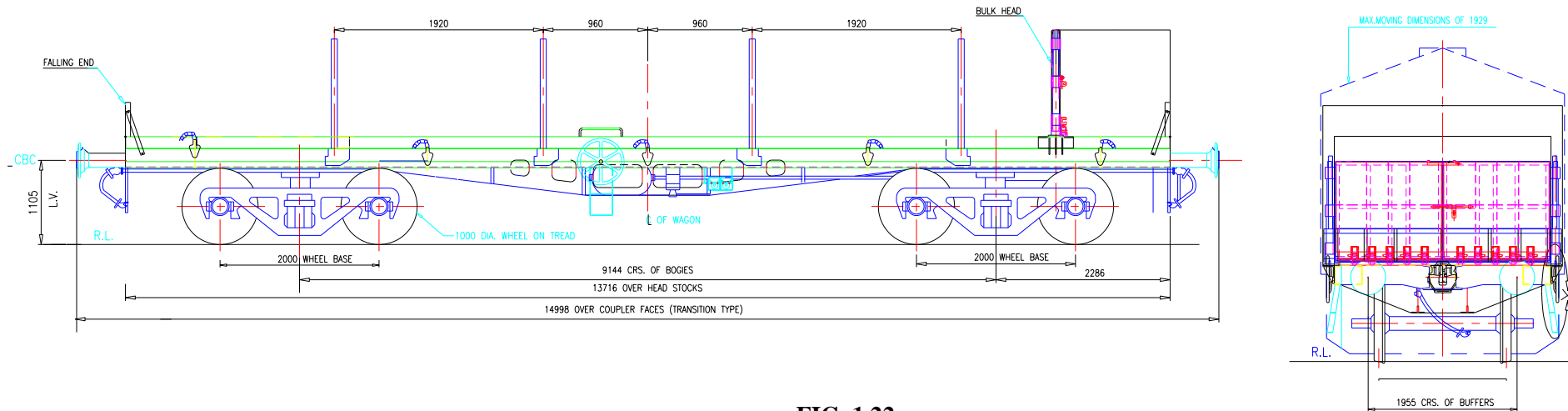


FIG. 1.22

**STANDARD FEATURES OF BRHNEHS WAGON (WD-04 004-S-52)**

S. No.	PARTICULARS	Parameter	S. No.	PARTICULARS	Parameter
1	Length over Hd. Stock	13716mm	11	Pay load	58.68 t.
2	Length over buffer/couplers	14986/14998 mm	12	Ratio pay load /tare	2.596
3	Length inside	12716mm	13	Gross load	81.28 t.
4	Width inside/overall	2845/3049 mm	14	No. of wagons per rake	41
5	Height inside/from rail	1264 mm/2008mm	15	Throughput per rake	2406 t.
6	Bogie centres	9144 mm	16	Loading density	5.419 t/m
7	Journal centres	2260 mm	17	Cubic capacity	Flat Wagon
8	Wheel dia. On tread	1000 mm	18	Speed (empty/ loaded)	65/65 kmph
9	Nominal max. axle load	20.32 t.	19	Type of coupler	Transition type CBC
10	Tare	22.6 t.	20	Type of bearing	CTRB (6X11) E-Class



**STANDARD FEATURES OF BRN WAGON - 22.9 t**

<b>S.No.</b>	<b>PARTICULARS</b>	<b>Parameter</b>	<b>S.No.</b>	<b>PARTICULARS</b>	<b>Parameter</b>
1	Length over Hd. Stock	13716mm	11	Pay load	68.292 t.
2	Length over buffer/couplers	14645 mm	12	Ratio pay load /tare	2.93
3	Length inside	13716 mm	13	Gross load	91.6 t.
4	Width inside/overall	2930 mm inside	14	No. of wagons per rake	42
5	Height inside/from rail	2555mm from R.L.	15	Throughput per rake	2868 t
6	Bogie centres	9144 mm	16	Loading density	6.25 t/m.
7	Journal centres	2260 mm	17	Cubic capacity	FLAT WAGON
8	Wheel dia. On tread	1000 mm	18	Speed (empty/ loaded)	65/65 Kmph
9	Nominal max. axle load	22.9 t.	19	Type of coupler	CBC
10	Tare	23.3 t.	20	Type of bearing	CTRB

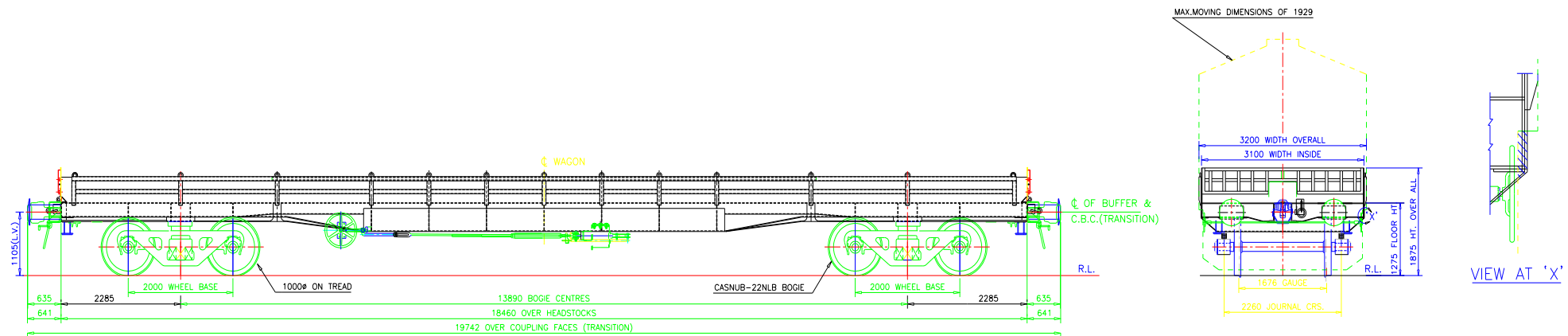


FIG. 1.23

**STANDARD FEATURES OF BOMN WAGON**

S. No.	PARTICULARS	Parameter	S. No.	PARTICULARS	Parameter
1	Length over Hd. Stock	18460mm	11	Pay load	35.850 t.
2	Length over buffer/couplers	19742 mm	12	Ratio pay load /tare	1.2
3	Length inside	18460 mm	13	Gross load	65.626 t.
4	Width inside/overall	3100/3200 mm	14	No. of wagons per rake	31
5	Height inside/from rail	1275 mm	15	Throughput per rake	-
6	Bogie centres	13890 mm	16	Loading density	3.324 t/m.
7	Journal centres	2260 mm	17	Cubic capacity	FLAT WAGON
8	Wheel dia. On tread	1000 mm	18	Speed (empty/ loaded)	80/75 Kmph
9	Nominal max. axle load	16.4 t.	19	Type of coupler	CBC
10	Tare	29.776 t.	20	Type of bearing	CTRB

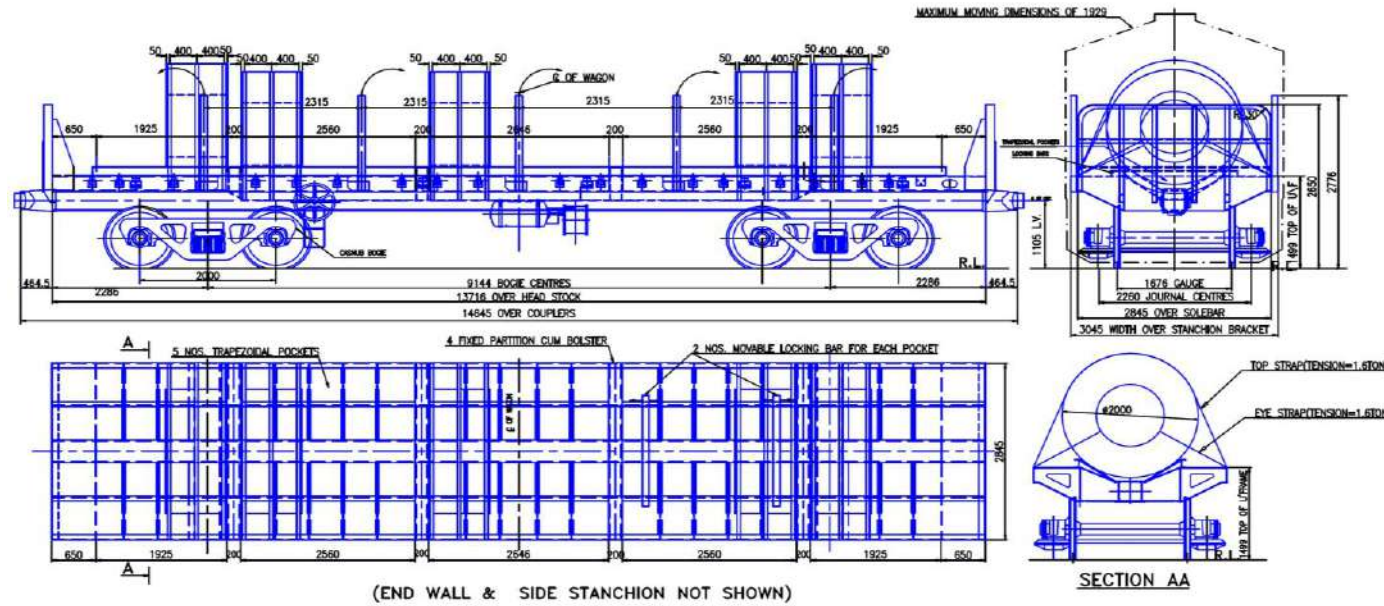


FIG. 1.24 BFNS FLAT WAGON (RDSO Drg. No. WD- 98057 – S- 02)

**INTRODUCTION:** - This bogie flat steel wagon is the one of the first wagon designed in Indian Railways to carry point load in 1998. The wagon was designed specially for transportation of hot rolled/cold rolled coils, plates, sheets and billets etc.

**STANDARD FEATURES OF 'BFNS' FLAT WAGON**

S.No	PARTICULARS	Parameter	S.No	PARTICULARS	Parameter
1	Length over head stock (mm)	13716	14	Maximum axle load (tonne)	20.32
2	Length over couplers (mm)	14645	15	Tare Weight (tonne)	26.71
3	Length inside (mm)	13716	16	Pay load (tonne)	54.57
4	Width inside/Width Overall (mm)	2845	17	Gross load (Pay+Tare) (tonne)	81.28
5	Height inside/Height (max.) from R.L.	---	18	Ratio gross load/Tare	3.043
6	Bogie centers (mm)	9144	19	Ratio (Pay load to tare)	2.043
7	Journal length × dia. (mm)	RB144.5 Ø	20	Track Loading density (tonnes/meter)	5.55
8	Journal centers (mm)	2260	21	No. of wagons per train	42
9	Wheel dia. on tread (New/Worn) (mm)	1000/906	22	Brake System	Air Brake
10	Height of C.B.C. from R.L. (mm)	1105	23	Coupler	C.B.C.
11	C.G. from R.L. (empty) (m)	-	24	Bearing	CTRB
12	C.G. from R.L. (loaded) (m)	-	25	Maximum Speed (Loaded)/ Empty	100/100 kmph (75/80Kmph, in case of speed certificate conditions not meeting)
13	Floor area (Sq.M)	-			

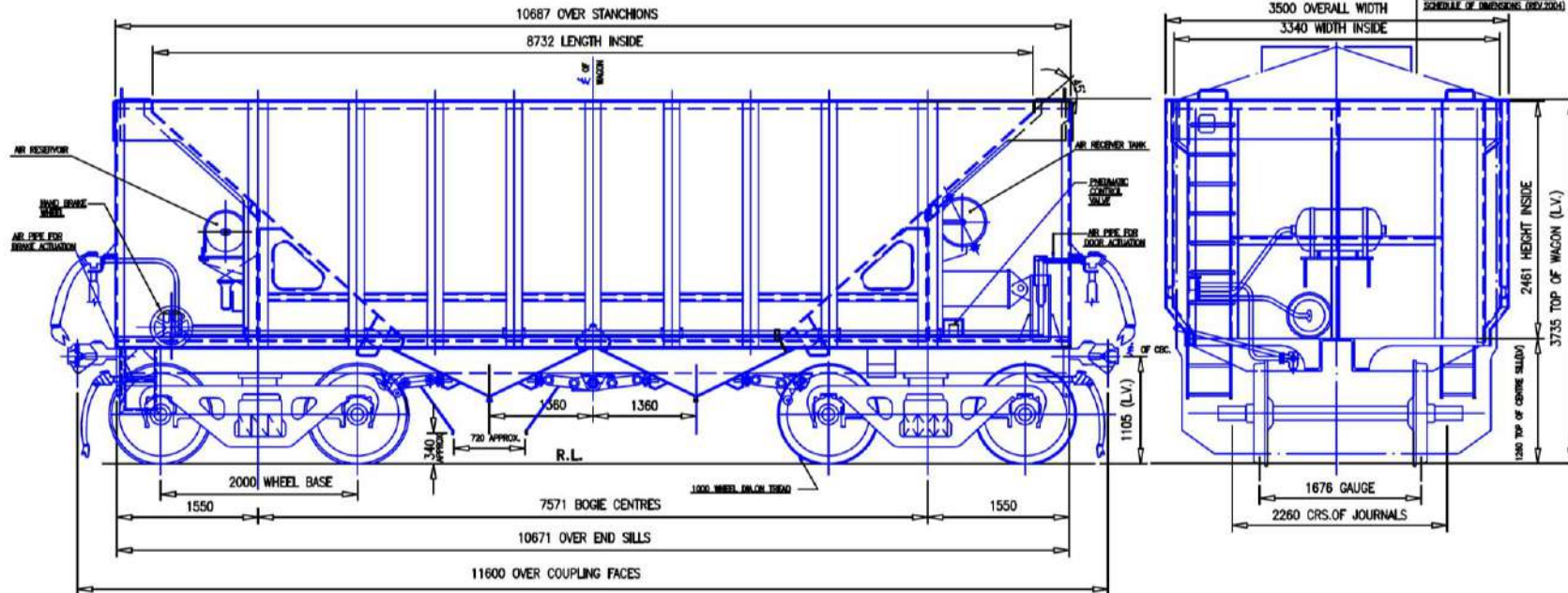


FIG. 1.25 HOPPER TYPE “BOBR” WAGON (RDSO Drg. No. WD – 86013 – S - 51)

**INTRODUCTION:** - This wagon is designed for transportation of coal with bottom discharge facility for faster evacuation.

**STANDARD FEATURES OF ‘BOBR’ HOPPER WAGON**

S.No	PARTICULARS	Parameter	S.No	PARTICULARS	Parameter
1	Length over head stock (mm)	10671	14	Cubic Capacity (Cu.M)	57.2
2	Length over couplers (mm)	11600	15	Maximum axle load (tonne)	20.32
3	Length inside (mm)	8732	16	Tare Weight (tonne)	26.40
4	Width inside/Width Overall (mm)	3340/3500	17	Pay load (tonne)	54.88
5	Height inside/Height (max.) from R.L.	2461/3735	18	Gross load (Pay+Tare) (tonne)	81.28
6	Bogie centres (mm)	7571	19	Ratio gross load/Tare	3.08
7	Journal length × dia. (mm)	RB144.5Ø	20	Ratio (Pay load to tare)	2.08
8	Journal centers (mm)	2260	21	Track Loading density (tonnes/meter)	7.00
9	Wheel dia. on tread (New/Worn) (mm)	1000/906	22	No. of wagons per train	53
10	Height of C.B.C. from R.L. (mm)	1105	23	Brake System	Air brake
11	C.G. from R.L. (empty) (m)	1.13	24	Coupler	C.B.C.
12	C.G. from R.L. (loaded) (m)	2.06	25	Bearing	CTRB
13	Floor area (Sq.M)	---	26	Maximum Speed (Loaded)/ Empty	80 kmph / 80 kmph

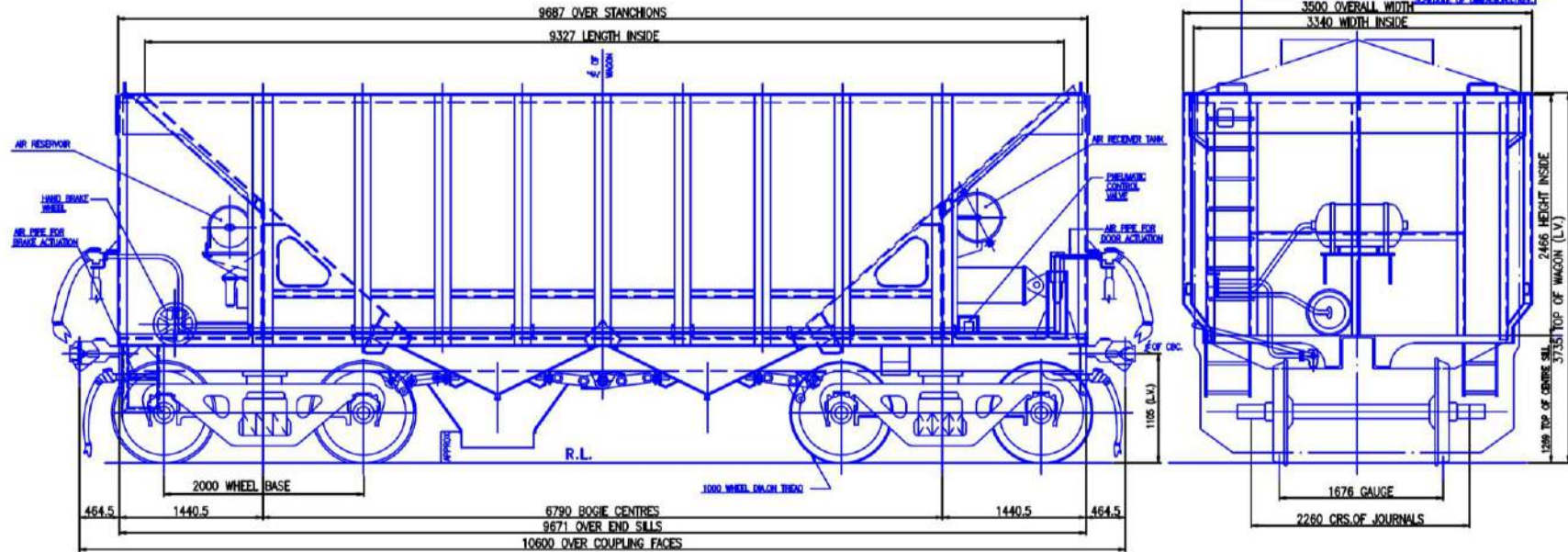


FIG. 1.26 HOPPER TYPE BOBRN WAGON (RDSO Drg. No. WD – 91071 – S - 51)

**INTRODUCTION:** - This wagon is a variant BOBR with air brake and has two doors.

**STANDARD FEATURES OF ‘BOBRN’ HOPPER WAGON**

S.No	PARTICULARS	Parameter	S.No	PARTICULARS	Parameter
1	Length over head stock (mm)	9671	14	Cubic Capacity (Cu.M)	56.78
2	Length over couplers (mm)	10600	15	Maximum axle load (tonne)	20.32
3	Length inside (mm)	9327	16	Tare Weight (tonne)	25.61
4	Width inside/Width Overall (mm)	3340/3500	17	Pay load (tonne)	55.67
5	Height inside/Height (max.) from RL.	2466/3735	18	Gross load (Pay+Tare) (tonne)	81.28
6	Bogie centers (mm)	6790	19	Ratio gross load/Tare	3.174
7	Journal length × dia. (mm)	RB144.5Ø	20	Ratio (Pay load to tare)	2.174
8	Journal centers (mm)	2260	21	Track Loading density (tonnes/meter)	7.67
9	Wheel dia. on tread (New/Worn) (mm)	1000/906	22	No. of wagons per train	58
10	Height of C.B.C. from R.L. (mm)	1105	23	Brake System	Air brake
11	C.G. from R.L. (empty) (m)	1.12	24	Coupler	C.B.C.
12	C.G. from R.L. (loaded) (m)	2.241	25	Bearing	CTRB
13	Floor area (Sq.M)	---	26	Maximum Speed (Loaded)/ Empty	70 kmph / 75 kmph

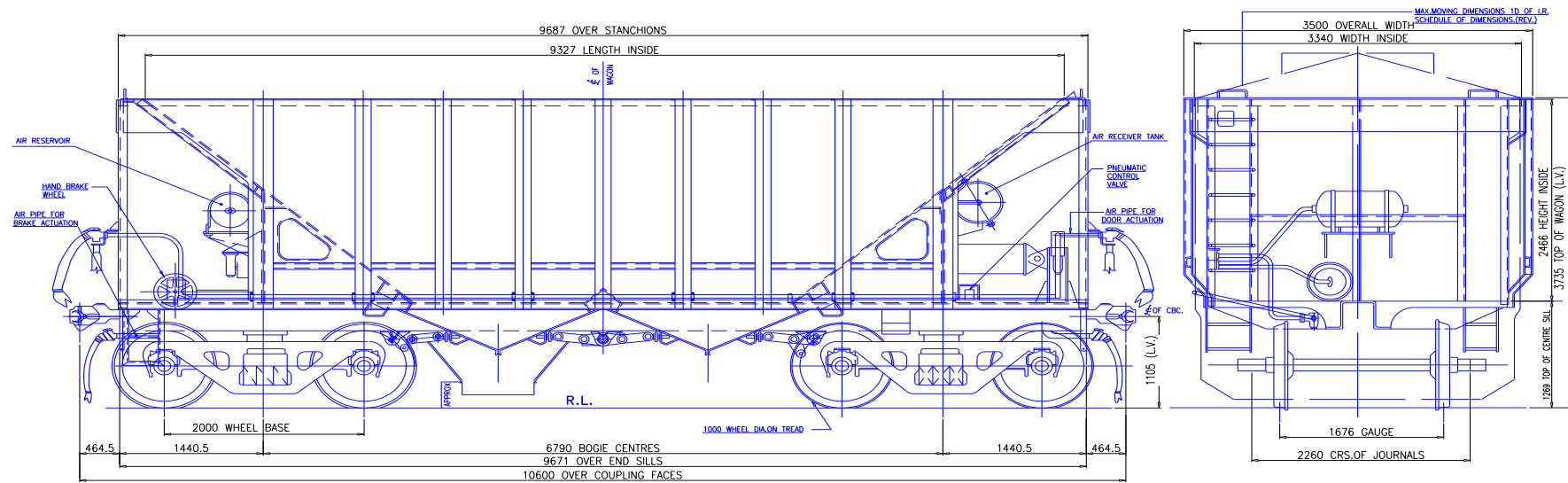


FIG. 1.27

**STANDARD FEATURES OF BOBRNHS WAGON (20.32 t) WD - 91071 - S - 51(Alt-10)**

S.No.	Particulars	Parameter	S. No.	Particulars	Parameter
1	Length over Hd. Stock	9671mm	11	Pay load	55.67 t.
2	Length over buffer/couplers	10600 mm	12	Ratio pay load /tare	2.17
3	Length inside	9327 mm	13	Gross load	81.28 t.
4	Width inside/overall	3340/3500 mm	14	No. of wagons per rake	58
5	Height inside/from rail	2466/3735 mm	15	Throughput per rake	3228.86 t.
6	Bogie centres	6790 mm	16	Loading density	7.67 t/m.
7	Journal centres	2260 mm	17	Cubic capacity	56.78 m3
8	Wheel dia. On tread	1000 mm	18	Speed (empty/ loaded)	100/100 Kmph
9	Nominal max. axle load	20.32 t.	19	Type of coupler	CBC
10	Tare	25.61 t.	20	Type of bearing	CTRB

**STANDARD FEATURES OF BOBRNHSM1 WAGON(22.32 t) (CC+6t+2t)**

S.No.	PARTICULARS	Parameter	S.No.	PARTICULARS	Parameter
1	Length over Hd. Stock	9671mm	11	Pay load	63.67 t.
2	Length over buffer/couplers	10600 mm	12	Ratio pay load /tare	2.48
3	Length inside	9327 mm	13	Gross load	89.28 t.
4	Width inside/overall	3340/3500 mm	14	No. of wagons per rake	58
5	Height inside/from rail	2466/3735 mm	15	Throughput per rake	3692.86 t
6	Bogie centres	6790 mm	16	Loading density	8.42 t/m
7	Journal centres	2260 mm	17	Cubic capacity	56.78 m <sup>3</sup>
8	Wheel dia. On tread	1000 mm	18	Speed (empty/ loaded)	65/60 Kmph
9	Nominal max. axle load	22.32 t.	19	Type of coupler	CBC
10	Tare	25.61 t.	20	Type of bearing	CTRB

**STANDARD FEATURES OF BOBRNEL WAGON (25.0 t) (Iron Ore)**

S.No.	PARTICULARS	Parameter	S.No.	PARTICULARS	Parameter
1	Length over Hd. Stock	9671mm	11	Pay load	74.39 t.
2	Length over buffer/couplers	10600 mm	12	Ratio pay load /tare	2.9
3	Length inside	9327 mm	13	Gross load	100.00 t.
4	Width inside/overall	3340/3500 mm	14	No. of wagons per rake	58
5	Height inside/from rail	2466/3735 mm	15	Throughput per rake	4314.62 t.
6	Bogie centres	6790 mm	16	Loading density	9.43 t/m.
7	Journal centres	2260 mm	17	Cubic capacity	(Marking has been done for loading of Iron Ore upto 1725 mm. Height from top of centre sill)
8	Wheel dia. On tread	1000 mm	18	Speed (empty/ loaded)	60+5/45+5 (Provisional) Kmph
9	Nominal max. axle load	25.00 t.	19	Type of coupler	--
10	Tare	25.61 t.	20	Type of bearing	--

**STANDARD FEATURES OF BOBRNM1 WAGON (22.32t) (CC+6t+2t)**

S.No.	PARTICULARS	Parameter	S.No.	PARTICULARS	Parameter
1	Length over Hd. Stock	9671mm	11	Pay load	63.67 t.
2	Length over buffer/couplers	10600 mm	12	Ratio pay load /tare	2.48
3	Length inside	9327 mm	13	Gross load	89.28 t.
4	Width inside/overall	3340/3500 mm	14	No. of wagons per rake	58
5	Height inside/from rail	2466/3735 mm	15	Throughput per rake	3692.86 t
6	Bogie centres	6790 mm	16	Loading density	8.42 t/m
7	Journal centres	2260 mm	17	Cubic capacity	56.78 m <sup>3</sup>
8	Wheel dia. On tread	1000 mm	18	Speed (empty/ loaded)	80/70 Kmph
9	Nominal max. axle load	22.32 t.	19	Type of coupler	CBC
10	Tare	25.61 t.	20	Type of bearing	CTRB

**STANDARD FEATURES OF BOBRN WAGON (22.32t) (CC+6t+2t)**

S.No.	PARTICULARS	Parameter	S.No.	PARTICULARS	Parameter
1	Length over Hd. Stock	9671mm	11	Pay load	63.67 t.
2	Length over buffer/couplers	10600 mm	12	Ratio pay load /tare	2.48
3	Length inside	9327 mm	13	Gross load	89.28 t
4	Width inside/overall	3340/3500 mm	14	No. of wagons per rake	58
5	Height inside/from rail	2466/3735 mm	15	Throughput per rake	3692.86 t.
6	Bogie centres	6790 mm	16	Loading density	8.42 t/m
7	Journal centres	2260 mm	17	Cubic capacity	56.78 m <sup>3</sup>
8	Wheel dia. On tread	1000 mm	18	Speed (empty/ loaded)	65/60 Kmph
9	Nominal max. axle load	22.32 t.	19	Type of coupler	CBC
10	Tare	25.61 t.	20	Type of bearing	CTRB



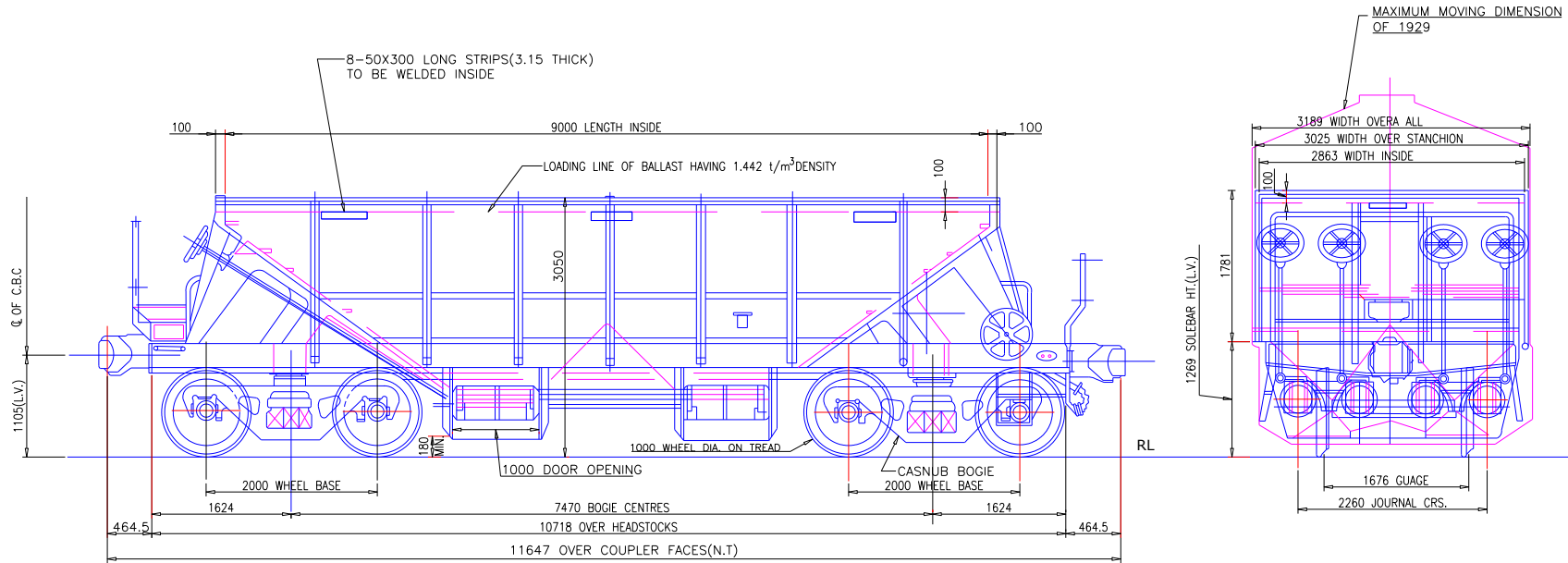


FIG. 1.28

**STANDARD FEATURES OF BOBYN/ BOBYNHS WAGON (WD-96081-S-02) (Alt-8)**

S.No.	PARTICULARS	Parameter	S.No.	PARTICULARS	Parameter
1	Length over Hd. Stock	10718mm	11	Pay load	66.4 t.
2	Length over buffer/couplers	11647 mm	12	Ratio pay load /tare	2.6
3	Length inside	9000 mm	13	Gross load	91.6 t.
4	Width inside/overall	2863/3189 mm	14	No. of wagons per rake	50 (in 585 M)
5	Height inside/from rail	2018/3287 mm	15	Throughput per rake	3320 t.
6	Bogie centres	7470 mm	16	Loading density	7.86 t/m
7	Journal centres	2260 mm	17	Cubic capacity	46.1 m <sup>3</sup>
8	Wheel dia. On tread	1000 mm	18	Speed (empty/ loaded)	--
9	Nominal max. axle load	22.9 t.	19	Type of coupler	NT. CBC
10	Tare	25.2 t.	20	Type of bearing	CTRB (6X11) EClass

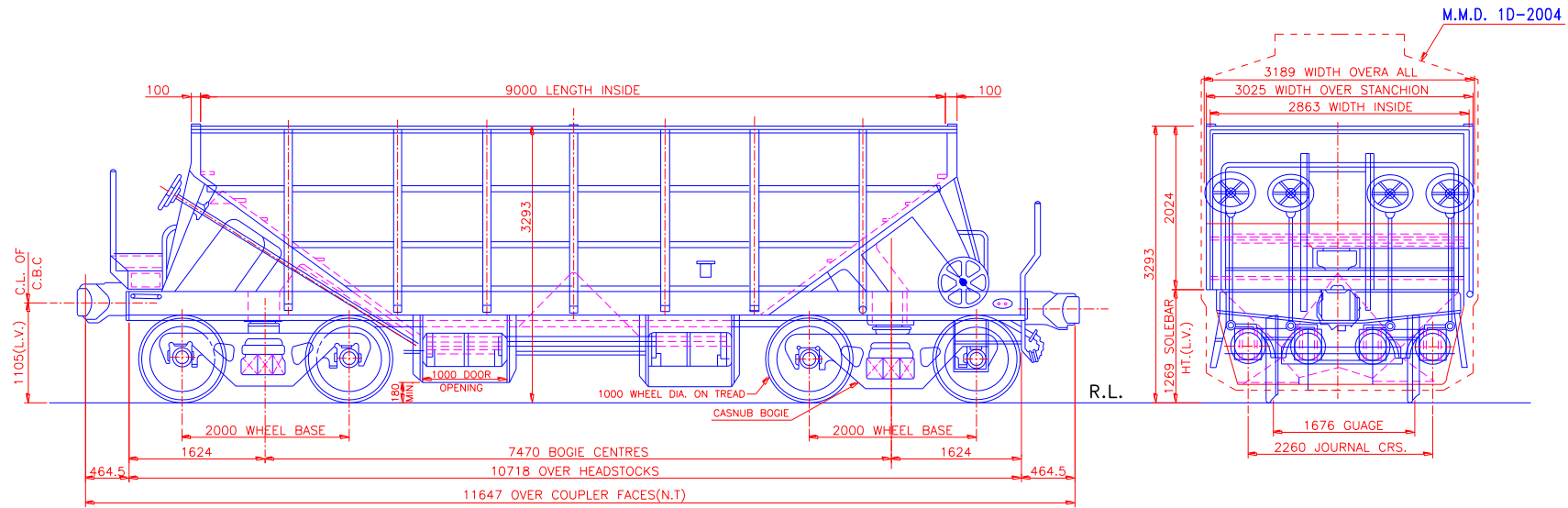


FIG. 1.29

**STANDARD FEATURES OF 'BOBYN 22.9' WAGON –(22.9 WD-09090-S-02) (Design B)**

S.No.	PARTICULARS	Parameter	S.No.	PARTICULARS	Parameter
1	Length over Hd. Stock	10718mm	11	Pay load	66.3 t.
2	Length over buffer/couplers	11647 mm	12	Ratio pay load /tare	2.6
3	Length inside	9000 mm	13	Gross load	91.6 t.
4	Width inside/overall	2863/3189 mm	14	No. of wagons per rake	50 (in 585 M)
5	Height inside/from rail	2024/3293 mm	15	Throughput per rake	3315 t.
6	Bogie centres	7470 mm	16	Loading density	7.86 t/m
7	Journal centres	2260 mm	17	Cubic capacity	46.16 m <sup>3</sup>
8	Wheel dia. On tread	1000 mm	18	Speed (empty/ loaded)	65/65 kmph.
9	Nominal max. axle load	22.9 t.	19	Type of coupler	NT. CBC
10	Tare	25.3 t.	20	Type of bearing	CTRB (6X11) EClass

**STANDARD FEATURES OF BOBSN WAGON (22.9 t.) Drg. No. WD-94038-S-02**

S.No.	PARTICULARS	Parameter	S.No.	PARTICULARS	Parameter
1	Length over Hd. Stock	10668mm	11	Pay load	61.6 t.
2	Length over buffer/couplers	11597mm	12	Ratio pay load /tare	2.05
3	Length inside	9296mm	13	Gross load	91.6 t.
4	Width inside/overall	2743/3020mm	14	No. of wagons per rake	-
5	Height inside/from rail	2042/3301mm	15	Throughput per rake	--
6	Bogie centres	7112 mm	16	Loading density	7.9 t/m.
7	Journal centres	2260 mm	17	Cubic capacity	34.0m <sup>3</sup>
8	Wheel dia. On tread	1000 mm	18	Speed (empty/ loaded)	--
9	Nominal max. axle load	22.9 T.	19	Type of coupler	CBC
10	Tare	30.0 t.	20	Type of bearing	CTRB

**STANDARD FEATURES OF BOBSNM1 WAGON (25.0 t.) Drg. No. WD-94038-S-02**

S.No.	PARTICULARS	Parameter	S.No.	PARTICULARS	Parameter
1	Length over Hd. Stock	10668mm	11	Pay load	70.0 t.
2	Length over buffer/couplers	11597 mm	12	Ratio pay load /tare	2.33
3	Length inside	9296mm	13	Gross load	100.00 t.
4	Width inside/overall	2743/3020 mm	14	No. of wagons per rake	-
5	Height inside/from rail	2042/3301mm	15	Throughput per rake	--
6	Bogie centres	7112 mm	16	Loading density	8.62 t/m.
7	Journal centres	2260 mm	17	Cubic capacity	34.0m <sup>3</sup>
8	Wheel dia. On tread	1000 mm	18	Speed (empty/ loaded)	55+5/45+5 Km/h
9	Nominal max. axle load	25.00t.	19	Type of coupler	CBC
10	Tare	30.0 t.	20	Type of bearing	CTRB

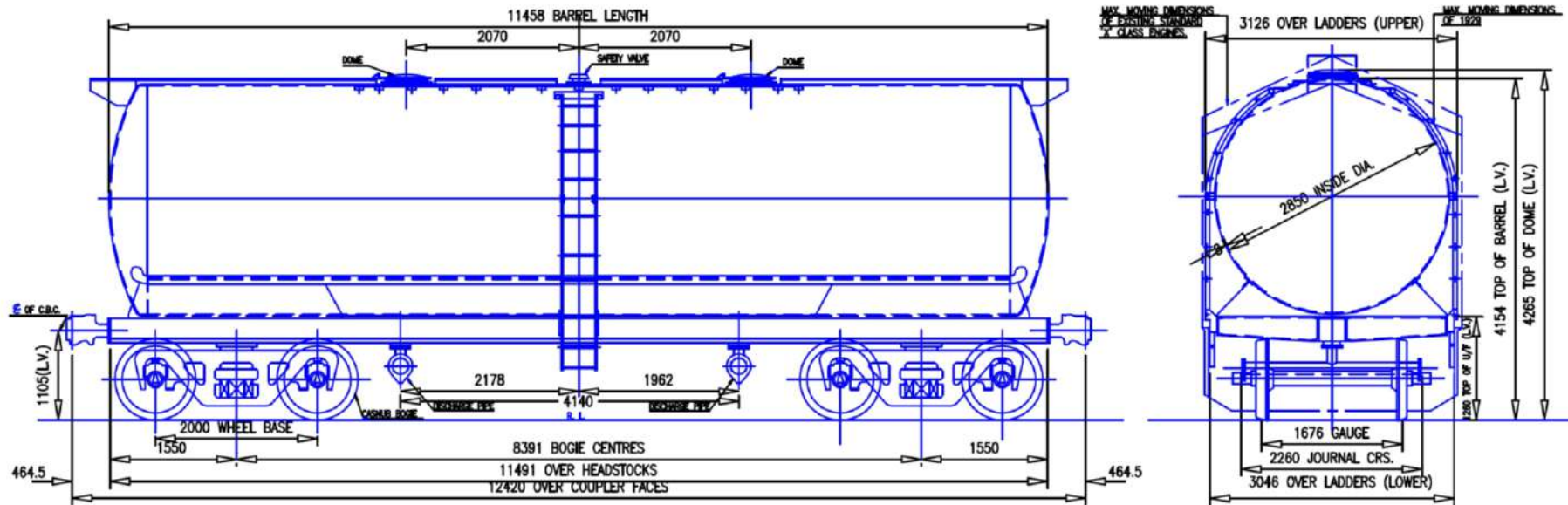


FIG. 1.30 BTPN TANK WAGON (RDSO Drg. No. WD – 86081 – S - 51)

**INTRODUCTION:** - This wagon has been designed for transportation of petroleum products i.e. kerosene, petrol, diesel and naphtha.

**STANDARD FEATURES OF ‘BTPN’ TANK WAGON**

S.No	PARTICULARS	Parameter	S.No	PARTICULARS	Parameter
1	Length over head stock (mm)	11491	14	Cubic Capacity (Cu.M)	70.40
2	Length over couplers (mm)	12420	15	Maximum axle load (tonne)	20.32
3	Length of barrel inside (mm)	11434	16	Tare Weight (tonne)	27.00
4	Dia. inside (barrel) (mm)	2850	17	Pay load (tonne)	54.28
5	Overall Height from R.L. (mm).	4265	18	Gross load (Pay+Tare) (tonne)	81.28
6	Bogie centers (mm)	8391	19	Ratio gross load/Tare	3.01
7	Journal length × dia. (mm)	277.8x144.5	20	Ratio (Pay load to tare)	2.01
8	Journal centers (mm)	2260	21	Track Loading density (tonnes/meter)	6.54
9	Wheel dia. on tread (New/Worn) (mm)	1000/906	22	No. of wagons per train	47
10	Height of C.B.C. from R.L. (mm)	1105	23	Brake System	Air brake
11	C.G. from R.L. (empty) (m)	1.43	24	Coupler	C.B.C.
12	C.G. from R.L. (loaded) (m)	2.23	25	Bearing	CTRB
13	Max. Volumetric carrying capacity (L)	---	26	Maximum Speed (Loaded)/ Empty	75 kmph / 80 kmph

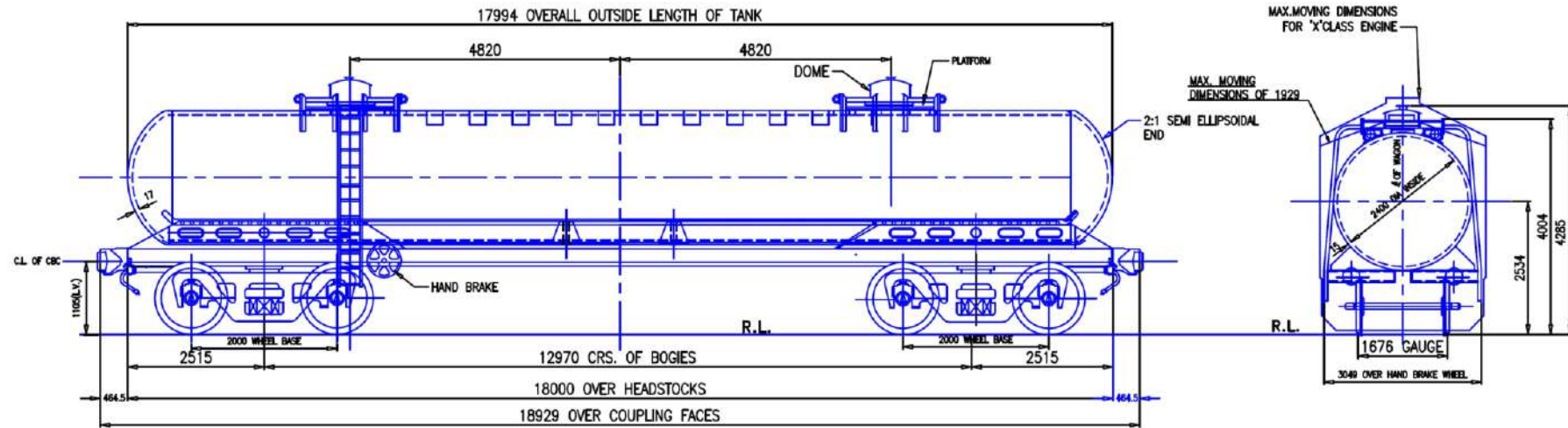


FIG. 1.31 BTPGLN TANK WAGON (RDSO Drg. No. WD – 93047 – S - 51)

**INTRODUCTION:** - This wagon is a variant of BTPGL with air brake and casnub trolley.

**STANDARD FEATURES OF 'BTPGLN' TANK WAGON**

S.No	PARTICULARS	Parameter	S.No	PARTICULARS	Parameter
1	Length over head stock (mm)	18000	14	Cubic Capacity (Cu.M)	79.48
2	Length over couplers (mm)	18929	15	Maximum axle load (tonne)	19.8
3	Length of barrel inside (mm)	17960	16	Tare Weight (tonne)	41.6
4	Dia. inside (barrel) (mm)	2400	17	Pay load (tonne)	37.6
5	Overall Height from R.L. (mm).	4285	18	Gross load (Pay+Tare) (tonne)	79.2
6	Bogie centers (mm)	12970	19	Ratio gross load/Tare	1.903
7	Journal length × dia. (mm)	RB 144.5 Ø	20	Ratio (Pay load to tare)	0.903
8	Journal centers (mm)	2260	21	Track Loading density (tonnes/meter)	4.184
9	Wheel dia. on tread (New/Worn) (mm)	1000/906	22	No. of wagons per train	31
10	Height of C.B.C. from R.L. (mm)	1105	23	Brake System	Air brake
11	C.G. from R.L. (empty) (m)	1.6	24	Coupler	C.B.C.
12	C.G. from R.L. (loaded) (m)	2.03	25	Bearing	CTRB
13	Max. Volumetric carrying capacity (L)	---	26	Maximum Speed (Loaded)/ Empty	75 kmph / 80 kmph

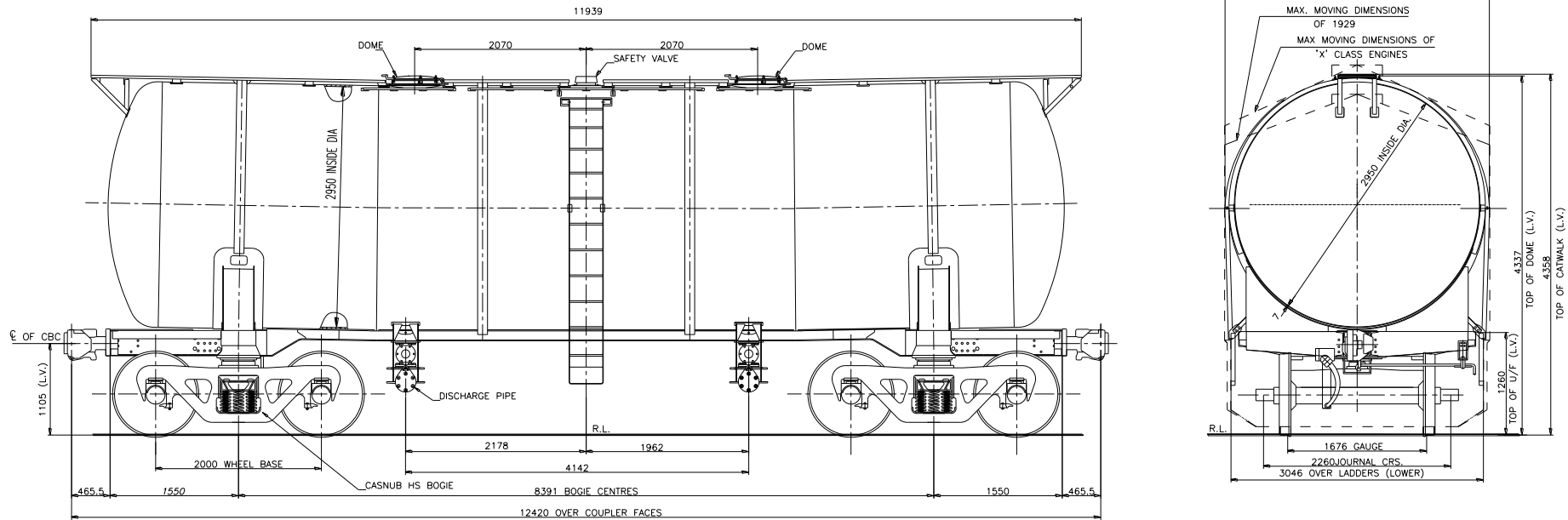


FIG. 1.32

**STANDARD FEATURES OF BTFLN WAGON (Pole Tank Wagon) (\* in 636 meters Loop length without safety wagon)**

S. No.	PARTICULARS	Parameter	S. No.	PARTICULARS	Parameter
1	Length over Hd. Stock	11491mm	11	Pay load	57.95
2	Length over buffer/couplers	12420 mm	12	Ratio pay load /tare	2.48
3	Length inside	11522 (inside Barrel length.)	13	Gross load	81.28 t.
4	Width inside/overall	2950(inside Dia. of Barrel)	14	No. of wagons per rake	51 *
5	Height inside/from rail	4358 (over all Ht.)	15	Throughput per rake	2955.45 t.
6	Bogie centres	8391mm	16	Loading density	6.54 t./m
7	Journal centres	2260 mm	17	Cubic capacity	76 m <sup>3</sup>
8	Wheel dia. On tread	1000 mm	18	Speed (empty/ loaded)	--
9	Nominal max. axle load	20.32 t.	19	Type of coupler	CBC
10	Tare	23.33 t.	20	Type of bearing	CTRB

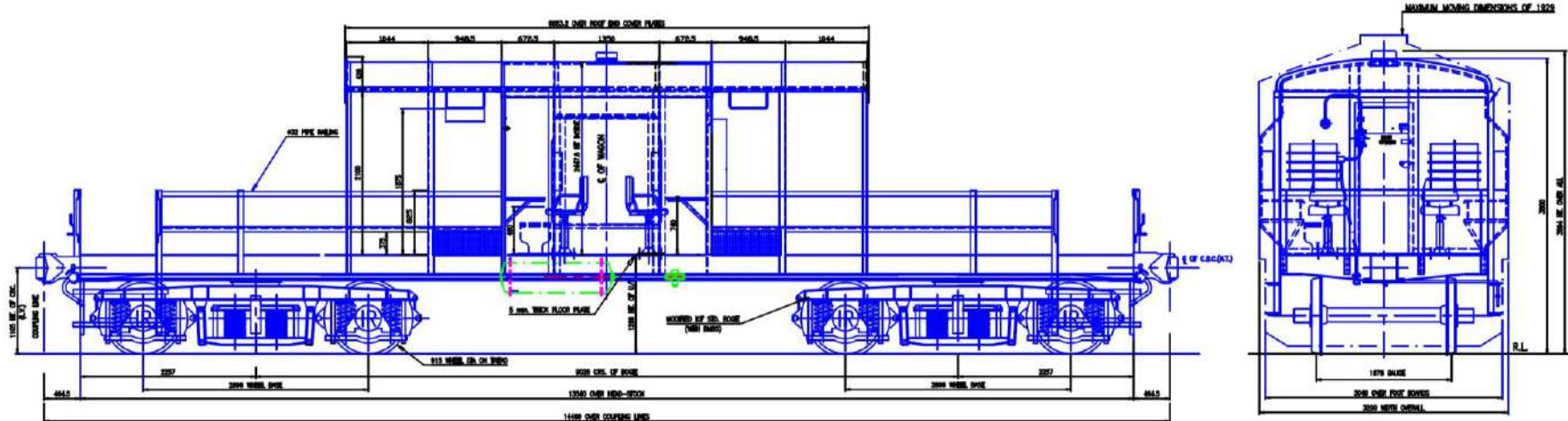


FIG. 1.33 BVZI BRAKE VAN (RDSO Drg. No. WD- 00039/ S- 02)

**INTRODUCTION:** - This 8-wheeled brake van was designed with ICF bogie to achieve comfort level (Ride Index) equivalent to loco criteria for goods guard and capable of running 100 kmph. The brake van was 5 meter longer than BVZC brake van.

**STANDARD FEATURES OF 'BVZI' BRAKE VAN**

S.No	PARTICULARS	Parameter	S.No	PARTICULARS	Parameter
1	Length over head stock (mm)	13540	14	Cubic Capacity (Cu.M)	----
2	Length over couplers (mm)	14469	15	Maximum axle load (tonne)	5.87520.32
3	Length inside (mm)	---	16	Tare Weight (tonne)	23.524.6
4	Width inside/Width Overall (mm)	-----/3200	17	Pay load (tonne)	-----56.68
5	Height inside/Height (max.) from R.L.	2448/3894	18	Gross load (Pay+Tare) (tonne)	23.5+....81.28
6	Bogie centers (mm)	9026	19	Ratio gross load/Tare	1.003.3
7	Journal length × dia. (mm)	----	20	Ratio (Pay load to tare)	----
8	Journal centers (mm)	----	21	Track Loading density (tonnes/meter)	1.6245.625
9	Wheel dia. on tread (New/Worn) (mm)	915/813	22	No. of wagons per train	-----
10	Height of C.B.C. from R.L. (mm)	1105	23	Brake System	Air Brake
11	C.G. from R.L. (empty) (m)	0.981	24	Coupler	C.B.C.
12	C.G. from R.L. (loaded) (m)	0.981	25	Bearing	CTRB
13	Floor area (Sq.M)	----	26	Maximum Speed (Loaded)/ Empty	100 kmph / 100 kmph

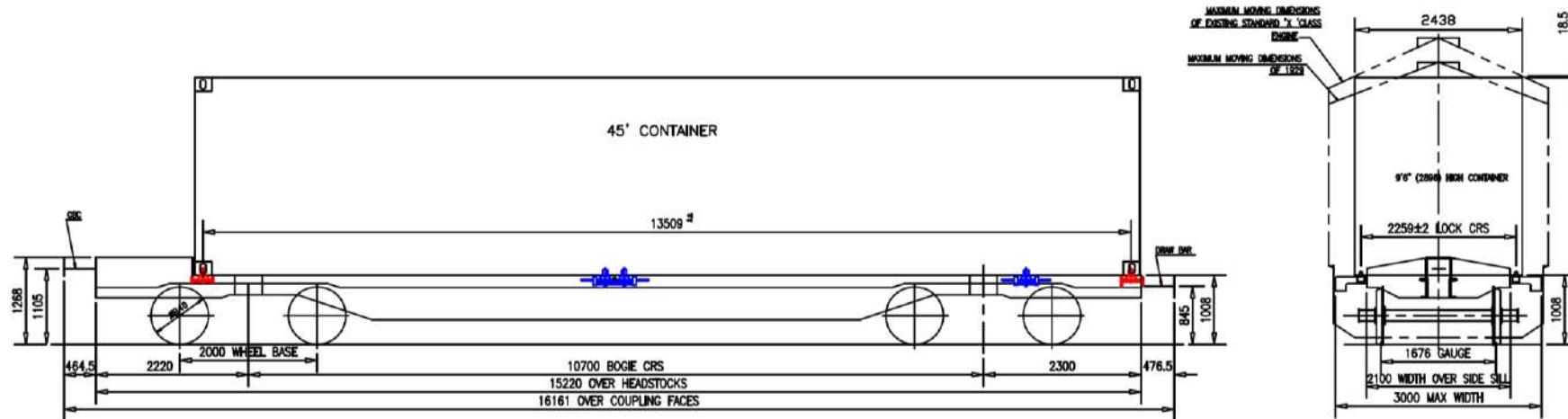


FIG. 1.34 BLLA CONTAINER WAGON (RDSO Drg. No. 45 – A – 2001 – S/02)

**INTRODUCTION:** - Bogie Low Platform Longer Container flat (BLL) wagons has been designed jointly by RDSO & RITES for transportation of 22’ 24’ & 45’ containers along with 20’ & 40’ long ISO containers at an operating speed of 100 kmph. Lower height of under frame floor from R.L. has been achieved with introduction of hybrid design of bogie frame, bolster and use of smaller diameter wheel in LCCF 20(C) Bogie. BLLA (A-Car) wagons are placed at extreme end in formation of one unit of 5- cars (with 3 BLLB wagons in middle). Outer end of BLLA wagons are fitted with standard AAR-E/F TYPE Center Buffer Coupler (C.B.C.) and inner ends are fitted with Slackless Draw Bar (S.D.B.). Wagons are fitted with automatic twist locks to secure containers.

**STANDARD FEATURES OF ‘BLLA’ CONTAINER WAGON**

S.No	PARTICULARS	Parameter	S.No	PARTICULARS	Parameter
1	Length over head stock (mm)	15220	14	Cubic Capacity (Cu.M)	----
2	Length over couplers (mm)	16161	15	Maximum axle load (tonne)	20.32
3	Length inside (mm)	---	16	Tare Weight (tonne)	19.8
4	Width over Headstock/Width over Bolster (mm)	2100/2200	17	Pay load (tonne)	61
5	Height inside/Height (max.) from RL.	1008	18	Gross load (Pay+Tare) (tonne)	80.8
6	Bogie centers (mm)	10700	19	Ratio gross load/Tare	4.08
7	Journal length × dia. (mm)	144x278	20	Ratio (Pay load to tare)	3.08
8	Journal centers (mm)	2260	21	Track Loading density (tonnes/meter)	5
9	Wheel dia. on tread (New/Worn) (mm)	840/780	22	No. of wagons per train of 45 wagons	16
10	Height of C.B.C/SDB from R.L. (mm)	1105/845	23	Brake System	Air Brake
11	C.G. from R.L. (empty) (m)	0.604	24	Coupler	C.B.C./S.D.B
12	C.G. from R.L. (loaded) (m)	1.998	25	Bearing	CTRB
13	Floor area (Sq.M)	----	26	Maximum Speed (Loaded)/ Empty	100 kmph / 100 kmph



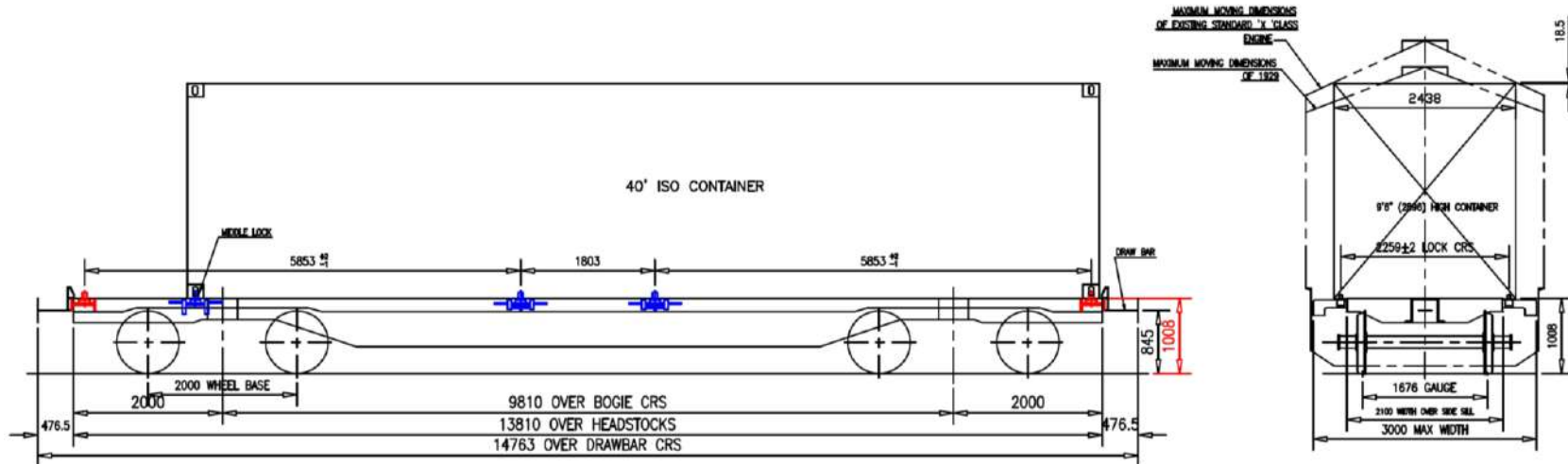
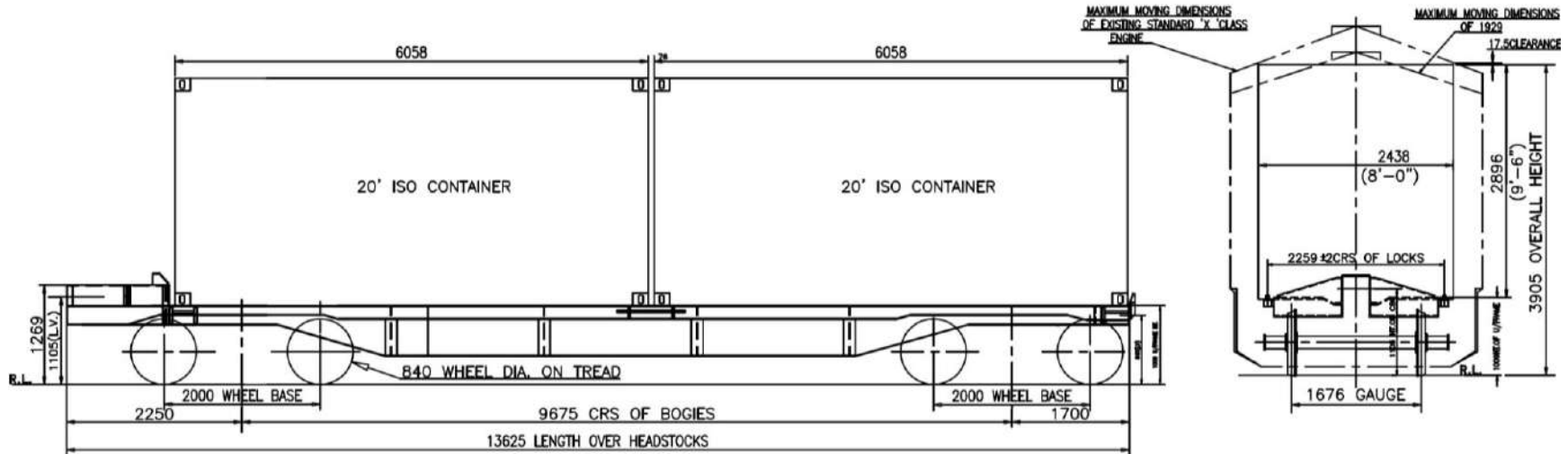


FIG. 1.35 BLLB CONTAINER WAGON (RDSO Drg. No. 45 – B – 2001 – S/02)

**INTRODUCTION:** - Bogie Low Platform Longer Container flat (BLL) wagons has been designed jointly by RDSO & RITES for transportation of 22' 24' & 45' containers along with 20' & 40' long ISO containers at an operating speed of 100kmph. Lower height of under frame floor from R.L. has been achieved with introduction of hybrid design of bogie frame, bolster and use of smaller diameter wheel in LCCF 20( C) Bogie. BLLB (B-Car) wagons are placed in middle, in one unit of 5- cars (with outer A-Cars). Both ends of BLLB wagons are fitted with Slack less Draw Bar (S.D.B.). Wagons are fitted with automatic twist locks to secure containers.

**STANDARD FEATURES OF 'BLLB' CONTAINER WAGON**

S.No	PARTICULARS	Parameter	S.No	PARTICULARS	Parameter
1	Length over head stock (mm)	13810	14	Cubic Capacity (Cu.M)	----
2	Length over couplers (mm)	14763	15	Maximum axle load (tonne)	20.32
3	Length inside (mm)	---	16	Tare Weight (tonne)	19
4	Width over Headstock/Width over Bolster (mm)	2100/2200	17	Pay load (tonne)	61
5	Height inside/Height (max.) from RL.	1008	18	Gross load (Pay+Tare) (tonne)	80
6	Bogie centers (mm)	9810	19	Ratio gross load/Tare	4.21
7	Journal length × dia. (mm)	144x278	20	Ratio (Pay load to tare)	3.21
8	Journal centers (mm)	2260	21	Track Loading density (tonnes/meter)	5.42
9	Wheel dia. on tread (New/Worn) (mm)	840/780	22	No. of wagons per train of 45 wagons	24
10	Height of S.D.B. from R.L. (mm)	845	23	Brake System	Air Brake
11	C.G. from R.L. (empty) (m)	0.603	24	Coupler	S.D.B
12	C.G. from R.L. (loaded) (m)	2.011	25	Bearing	CTRB
13	Floor area (Sq.M)	----	26	Maximum Speed (Loaded)/ Empty	100 kmph / 100 kmph



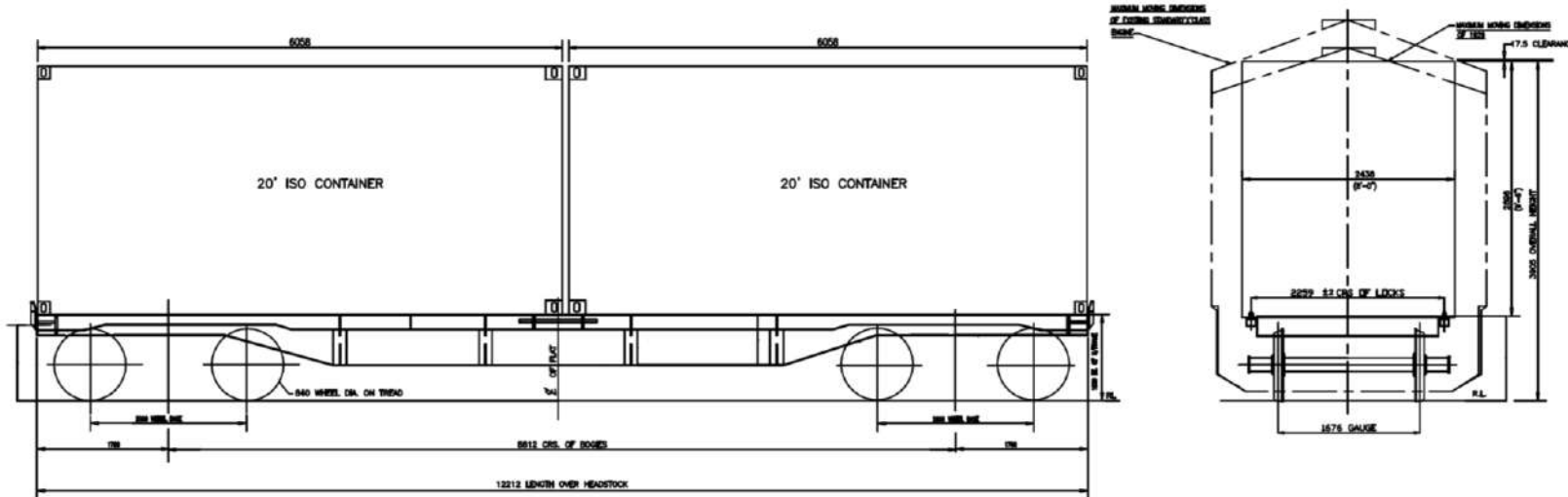
**FIG. 1.36 BLCA CONTAINER WAGON (RDSO Drg. No. CONTR – 9405 – S/2)**

**INTRODUCTION:** - Bogie Low Platform Container flat (BLC) wagons has been designed for transportation of 20' & 40' long ISO containers at an operating speed of 100kmph. Lower height of under frame( floor) from R.L. has been achieved with introduction of hybrid design of bogie frame, bolster and use of smaller diameter wheel in LCCF 20( C) Bogie.

BLCA (A-Car) wagons are placed at extreme ends in formation of one unit of 5- cars (with 3 BLCB wagons in middle). Outer end of BLCA wagons are fitted with standard AAR-E/F TYPE Center Buffer Coupler (C.B.C.) and inner ends are fitted with Slack less Draw Bar (S.D.B.). Wagons are fitted with automatic twist locks to secure containers.

**STANDARD FEATURES OF 'BLCA' CONTAINER WAGON**

S.No	PARTICULARS	Parameter	S.No	PARTICULARS	Parameter
1	Length over head stock (mm)	13625	14	Cubic Capacity (Cu.M)	----
2	Length over couplers (mm)	14566	15	Maximum axle load (tonne)	20.32
3	Length inside (mm)	---	16	Tare Weight (tonne)	19.1
4	Width over Headstock/Width over Bolster (mm)	2100/2200	17	Pay load (tonne)	61
5	Height inside/Height (max.) from RL.	1269/1009	18	Gross load (Pay+Tare) (tonne)	80.1
6	Bogie centers (mm)	9675	19	Ratio gross load/Tare	4.21
7	Journal length × dia. (mm)	144x278	20	Ratio (Pay load to tare)	3.194
8	Journal centers (mm)	2260	21	Track Loading density (tonnes/meter)	5.5
9	Wheel dia. on tread (New/Worn) (mm)	840/780	22	No. of wagons per train of 45 wagons	18
10	Height of C.B.C./S.D.B. from R.L. (mm)	1105/845	23	Brake System	Air Brake
11	C.G. from R.L. (empty) (m)	0.551	24	Coupler	C.B.C/S.D.B
12	C.G. from R.L. (loaded) (m)	1.993	25	Bearing	CTRB
13	Floor area (Sq.M)	----	26	Maximum Speed (Loaded)/ Empty	100 kmph / 100 kmph



**FIG. 1.37 BLCB CONTAINER WAGON (RDSO Drg. No. CONTR – 9406 – S/2)**

**INTRODUCTION:** - Bogie Low Platform Container flat (BLC) wagons has been designed for transportation of 20’ & 40’ long ISO containers at an operating speed of 100kmph. Lower height of under frame floor from R.L. has been achieved with introduction of hybrid design of bogie frame, bolster and use of smaller diameter wheel in LCCF 20 (C) Bogie.

BLCB (B-Car) wagons are placed in middle, in one unit of 5- cars (with outer A-Cars). Both ends of BLCB wagons are fitted with Slack less Draw Bar (S.D.B.). Wagons are fitted with automatic twist locks to secure containers.

**STANDARD FEATURES OF ‘BLCB’ CONTAINER WAGON**

S.No	PARTICULARS	Parameter	S.No	PARTICULARS	Parameter
1	Length over head stock (mm)	12212	14	Cubic Capacity (Cu.M)	----
2	Length over couplers (mm)	13165	15	Maximum axle load (tonne)	20.32
3	Length inside (mm)	---	16	Tare Weight (tonne)	18
4	Width over Headstock/Width over Bolster (mm)	2100/2200	17	Pay load (tonne)	61
5	Height inside/Height (max.) from RL.	1009	18	Gross load (Pay+Tare) (tonne)	79
6	Bogie centers (mm)	8812	19	Ratio gross load/Tare	4.38
7	Journal length × dia. (mm)	144x278	20	Ratio (Pay load to tare)	3.39
8	Journal centers (mm)	2260	21	Track Loading density (tonnes/meter)	6
9	Wheel dia. on tread (New/Worn) (mm)	840/780	22	No. of wagons per train of 45 wagons	27
10	Height of S.D.B. from R.L. (mm)	845	23	Brake System	Air Brake
11	C.G. from R.L. (empty) (m)	0.548	24	Coupler	S.D.B
12	C.G. from R.L. (loaded) (m)	2.013	25	Bearing	CTRB
13	Floor area (Sq.M)	----	26	Maximum Speed (Loaded)/ Empty	100 kmph / 100 kmph



*( MAINTENANCE MANUAL FOR WAGONS- 2015 )*

## **CHAPTER – 2**



# **MAINTENANCE, WARRANTY & CONDEMNATION**



## CHAPTER 2

### MAINTENANCE, WARRANTY & CONDEMNATION

This chapter gives general information about periodicity of various types of inspections and maintenance schedules for goods stock on open line. Prescribed period at which POH is to be carried out on various types of stock has also been given. However, special practices to be followed for repairs during POH are indicated in the concerned chapters later in the manual.

At the end of this chapter, prescribed intervals for POH and ROH of wagons at a glance are given in the tables 2.1, 2.2 & 2.3.

#### 201. WARRANTY INSPECTION OF NEWLY BUILT WAGONS

- a) All newly built wagons have a warranty period of 24 months or as prescribed in the purchase contract. In accordance with the conditions mentioned in the wagon manufacturing contracts, the charges for rectification of the following category of defects can be realised from the wagon builder :-
- Use of inferior material
  - Poor workmanship on the part of contractor
  - Imperfect protection
  - Other faults on the part of contractor which are noticed during the warranty period.
- b) To enable the Railway Board to realise the warranty charges, a systematic inspection of new wagons must be undertaken by representative of C&W to locate defects during the warranty period. The following procedure is laid down for this purpose:-
- (i) All newly built wagons turned out must bear the warranty legend stencilled on both sides of the wagons. The warranty legend will consist of the following particulars:-
- Contract Number
  - Date of Commissioning
  - Commissioned by
  - Inspection due on
  - Inspection done by \_\_\_\_\_ Depot \_\_\_\_\_ Date \_\_\_\_\_
- (ii) Whenever wagons due for warranty inspection pass nominated yards, preferably detach them from the train and send to sick line for a systematic check.
- (iii) Examination of Defects:  
During the course of warranty inspection, it must be borne in mind that only those defects, which are attributable to the manufacturer due to use of inferior material, poor workmanship, improper protection or any other faults, are to be

reported. The following are some of the defects, which fall under this category:-

**A) Welding defects**

- All types of welding failures
- Welding defects such as insufficient or unequal leg length of fillet weld, porosity, lack of fusion, etc.

**B) Riveting/ Lock Bolting defects**

- Loose rivets/ Lock bolts
- Badly formed rivet heads/ Lock bolt's collars
- Rivets with staggered heads
- Improperly filled holes
- Pin tail of lock bolt not removed.

**C) Manufacturing /Fitting Defects**

- Improper manufacturing/ fitting of parts

**D) Material failures such as breakage of:**

- **CBC components**
- **Centre pivots**
- **DV/ brake cylinder**
- **EM pads/ PU side bearers**

**E) Improper Protection**

- Improper painting of underframe body, roof and components resulting in corrosion
- Wagons not being water tight

**F) Train Pipe leakage and unsatisfactory working of brake cylinders**

**G) Roller Bearing Defects**

Wagons fitted with roller bearings are normally examined only in major sick lines. If any defect is noticed, the entire wheel assembly must be sent to the workshop. After inspection in the workshop, if it is felt that the defect is attributable to the contractor/ manufacturer, the workshop incharge should report the defect to the concerned roller bearing manufacturer and others concerned. Since the Railways normally supply wheels and axles to the builder, defects noticed on the wheel and axles need not be reported to the wagon builders. However, the extant instructions for reporting any defect on the wheels and axles must be followed.

The procedure of warranty inspection of BTPN wagons is same as above with special attention to internal and external examination of barrel

for any failure of longitudinal/ circumferencial joint, lamination defects in barrel and dish end plates, cracks in barrel, leakage by barrel fittings and examination of cradles and anchoring rivets as per Technical pamphlet No. G-90.

**c) METHOD OF REPORTING**

A. The particulars, which are to be furnished, are as follows:-

**i. Contract No.**

This indicates the contract number under which the order has been placed by the Railway Board on the Wagon Builders for the manufacturer of wagons. This will be stencilled on the wagon in the Warranty legend. The representative of C&W should ensure that correct particulars as obtained from the wagon are filled.

**ii. Wagon number**

**iii. Wagon Code**

**iv. Owing Railway**

**v. Month and Year of manufacture**

**vi. Name of the Manufacturer**

**vii. Date of Warranty Inspection**

**viii. Defects attributable to the Manufacturer** - All the defects attributable to the manufacturer should be clearly indicated. The actual location of the defect should be clearly recorded.

In the case of material failure, it is essential that such items should be sent to the Chemist and Metallurgist of the respective Railways so as to enable him to submit the test reports. While sending the materials to the CMT, the particulars of the wagon i.e. the wagon No., owing Railway, Wagon code the Builders' name, the Contract Number and the serial number of the Warranty Inspection Report must be mentioned in the forwarding memo. These particulars can be included in the Test Report submitted by the CMT. This will facilitate in connecting the test reports with the respective Warranty reports at the Railway Board's Office.

The CMT will send his analysis report direct to the Railway Board's office. In order to prefer the claims expeditiously as possible, it is desired by the Board that the reports of Chemist and Metallurgist should be sent to the Secretary (WP), Warranty, Railway Board, New Delhi, within 20 days from the date of warranty inspection. The report of the CMT should not be sent to the wagon Builders.

A 'NIL' defect report should be sent if there are no defects attributable to the manufacturers.



**B. Estimated cost of rectification**

No estimates are to be furnished by representative of C&W in the warranty inspection reports. Against this column, simply mention “Cost will be advised by the Railway Board”.

*Along with other remarks, if any, a written certificate must be given to the effect that the defects mentioned have arisen due to inferior material (i.e. material of wrong specification or cheap quality) or bad workmanship (poor workmanship like bad riveting, welding, fitting etc.) or imperfect protection of the components (Brake cylinder rusted etc.) or any other defaults on the contractor’s part.*

**C. Numbering of the report**

In order to enable the Board’s office to keep a check on the performance of each nominated C&W Depot and also to detect the missing reports, all Warranty Inspection Reports must be serially numbered.

*For uniformity it is desired that the C&W Depots should indicate the number of Warranty reports in three barrels by indicating the station code in the first barrel, Warranty in the 2nd barrel and serial number of the report in the last barrel. For example ASN/WTY/81 indicates that this warranty report was sent from Asansol Wagon depot, ‘WTY’ refers to Warranty report and ‘81’ refers to the serial number of the warranty report i.e. serial number the wagon which has been warranty inspected from the commencement of the inspection.*

Date on which the Warranty report is submitted must be indicated. The representative of C&W who signs the report should ensure that his designation is properly recorded by affixing his rubber stamp, which should indicate the designation as well as the reporting station.

**D. Disposal of the Proforma**

- In the case of wagons built by railway workshops, the report should be sent to the following addresses :-
  1. The workshop which manufactured the wagon
  2. CME of the manufacturing Railway.
  3. Secretary (WP)/Railway Board/New Delhi.
  4. CME of the inspecting zonal railway
  5. Sr. D.M.E. of the inspecting division
- In the case of wagons built by private manufacturers, the report should be sent to the following addresses :-
  1. Wagon builder
  2. Secretary (WP)/Railway Board, New Delhi.
  3. G.M.(Mech.) of the inspecting zonal railway
  4. CME of the inspecting zonal railway
  5. Sr. D.M.E. of the inspecting division.

- E. It is necessary that Senior Divisional Mechanical Engineer must send the warranty inspection report to the parties indicated above after inspection without any delay.
- F. After submission of the warranty reports, the Railway Board will decide the finalisation of claims. If any wagon builder returns the warranty report or refuses to accept the claim, such cases must be immediately advised to Railway Board.

#### d) MAINTENANCE OF RECORDS

*The Train Examining Depot should maintain following files and registers:*

- One file for filing all the policy instructions on warranty inspection received from their divisional office/CME. The representative of C&W should be conversant with the instructions issued from time to time. It is desired that an index sheet be maintained giving the particulars of the letters so as to keep a continuity of all the instructions.
- A second file for filling all the warranty inspection reports, intermediate or finally submitted by the Depot.
- A third file should be maintained for filing all correspondence regarding warranty inspection, periodical statements of inspections carried out etc.
- A register should be maintained giving the following details of the wagons inspected during the warranty period :-
  - a) **Date of Inspection**
  - b) **Wagon No.**
  - c) **Owning Railway**
  - d) **Wagon Code**
  - e) **Name of Builder**
  - f) **Date of Commissioning**
  - g) **Defects noticed**
  - h) **Warranty inspection report no. and Date**
  - i) **Remarks**

The above inspection procedure of warranty inspection does not in any way preclude any Railway from reporting any defect direct to the wagon builder and to the parties mentioned above. In the same manner, if defects are noticed at any time during the warranty period. During the intermediate warranty inspection, stencilling of the Station Code and date of Inspection should not be done on the wagon. This should only be done at the time of final warranty inspection.

## 202. EXAMINATION AND MAINTENANCE PERIODICITY

### a) ROLLING IN EXAMINATION

All terminating trains are to be given “Rolling-in-examination” while entering a station having a train examining depot. After rolling in examination when the train stops in yard, immediately feeling of axle boxes is necessary to detect hot/ warm axle box.

**b) EXAMINATION OF TERMINATING LOAD**

Examination of terminating loads is to be carried out as soon as the train comes to a halt. For the examination of terminating loads, the pattern of train examination issued by individual Zonal Railway keeping in view the Railway Board's guidelines issued vide their letter no. 94/M(N)/951/57 dated 28.2.2000 or latest instructions shall be followed.

**c) EXAMINATION OF TRAIN AT ORIGINATING STATION**

- i. The train examining staff must ensure that the wagons are in fit condition and do not have any rejectable defects. A certificate has to be given to the Station Master by Sr. SE/JE(C&W) to this effect before despatch of the train. Before issuing fit Certificate, train examining staff to ensure requisite percentage of brake power. For details refer Chapter 3.
- ii. The level of air pressure on the engine & brake van alongwith the percentage of effective brake cylinders must be recorded on the brake certificate duly countersigned by the driver and guard.
- iii. Wagons, which have been humped, must be specially checked for damages occurring due to impacts during humping.

**d) MAKING WAGONS FIT TO RUN BY PASSENGER TRAIN**

Goods wagon may be attached to a passenger train provided the maximum speed to the train does not exceed 100 Kmph. The wagons must satisfy the following condition:- (RDSO letter No. MW/BCNA dated 30.05.2003 and MW/BOXN dated 04.07.2003.)

- i. They are fully fitted with operative brake cylinders
- ii. The wagon should not be overloaded or unevenly loaded
- iii. Wagon fitted with wheels having no star marks on journal cap to be ensured by duly opening the Axle Box cover
- iv. Wagons should not be overdue POH/ROH

**e) INTENSIVE EXAMINATION**

The purpose of intensive examination of goods stock is to permit extended run of through trains by raising the general standard of fitness of rolling stock by concentrated attention at the time of despatch from originating yards.

**Note:** The details of above examinations are given in Chapter 3.

### 203. ROH OF AIR BRAKE WAGON WITH CASNUB BOGIE

Wagon stock should be given Routine Over-Haul (ROH) at the nominated sick line/wagon depots, where proper facilities are provided (for details, see para 206, table No. 2.2). The ROH schedule is as follows:

- a) Lift the body, keep it on trestles and run out bogies.
- b) Strip bogie component for examination and repair as below:
  - Strip spring & spring suspension arrangement including snubbing device. Check springs for free height and other defects. Replace where required.
  - Examine Bogie frame. Check frame alignment as per instructions contained in RDSO Technical Pamphlet No. G-95.
  - Examine pivot for welding defects/cracks/abnormal depth due to wear. Replace where necessary and lubricate with graphite flakes to IS:495 in dry condition.
- c) Strip brake gear levers and rods for examination of worn out/damaged parts.
- d) The equipment shall be given attention in accordance with the maintenance manual issued by respective air brake equipment manufacturer and RDSO technical pamphlet no. G-97.
  - i. Cleaning of strainer discs (Reference 6 & 218 of the pamphlet SBA 795/258 of P4aG type Distributor Valve)
  - ii. Lubrication of brake cylinder/cleaning of its strainer
  - iii. Check for easy operation of isolating cock & anti-pilferage device of distributor valve cut-off angle cock, manual quick release valve & isolating cock.
  - iv. Draining of Auxiliary Reservoir
  - v. Checking of hose coupling for serviceability
  - vi. Cleaning of strainer
  - vii. Dirt collector to be cleaned
  - viii. Leakage in pipes and joints to be checked
  - ix. After carrying out above items of work the wagon shall be tested for proper function of air brake system with single car test device in accordance with the procedure indicated below :
    - Connect the BP coupling of single car test rig to the corresponding coupling of the wagon to be tested .The couplings of the other end of the wagon to be closed with dummy coupling heads .Fix pressure gauge on the brake cylinder.
    - The single car test device should now be coupled to the main line of a compressor through a pipe.
    - Carry out the preparation and testing in accordance with the procedure given in the manufacturers Maintenance Manual and record the reading in the test proforma.
    - For passing the wagon, all the parameters shall be within specified limits.
- e. Clean horizontal lever, hand brake & gears and lubricate
- f. Examine head stock for damage, bent/cracks

- g. Refit brake gear levers and rods, lubricate pins and other equipment and apply graphite to horizontal levers of empty load box
- h. Replace worn out brake blocks
- i. Check wheel profile, turn the wheels. UST of Axle to be carried out & turning of wheel to worn wheel profile during ROH be done.
- j. All the wheels are to be checked ultrasonically & ensure stamping as per Annexure IV and End Axle cap bolts are to be tightened up by torque wrench with proper torque (40 kg-m) and in no case old locking plates are to be reused .
- k. CBC Knuckles and coupler body are to be checked by contour gauge as per Technical Pamphlet no. G-76. Anti creep/ articulated rotary operation of locking arrangement to be checked.
- l. Manual adjustment of brake gear to be done in accordance with wheel diameter. Setting of Empty load device and A & E dimension of SAB shall also be done before SWTR test.
- m. Modification work are to be attended as issued by RDSO from time to time.
- n. CTRB of wheel should not be over due POH schedule.

## 204. CATEGORISATION OF WAGON REPAIR

*Classification of wagon repairs have been rationalised under the following nomenclature:-*

- a) **Petty Repairs** :- Repairs involving not more than 8 man - hours. Such repairs are to be normally carried out on nominated lines in traffic yards in less than 8 man hours.
- b) **Medium Repairs** :- Repairs involving more than 8 man - hours and upto 100 man - hours. These would normally cover repairs to underframe members viz. head stock, middle bars, sole bars, changing of axle guards, wheel changing heavy panel patching, heavy floor repairs, etc. Such repairs are to be carried out in sick lines.
- c) **Special Repairs** :- Repairs to heavily damaged wagons involving more than 100 man hours. Such repairs may be carried out either in the workshops or in major sick line. Recommended work areas where serious repairs should be carried out are given in the Table 2.4 at the end of this chapter. Repair to under frame members and other heavy work should be dealt in properly equipped major and medium sickline. Repair to under frame members viz. patching of headstock, sole bar and middle bars, strengthening of bulged ends, replacement of end angle, fitment of more than 5 new full width panel patches, replacement of axle guards to be done in sickline / wagon depot.

***“BOXN wagon variants requiring repair are classified as under:***

**Category A** : BOXN wagons requiring petty repairs which can be attended in sick lines.

**Category B** : unloadable BOXN wagons, which require attention/body repairs in well equipped sick lines or ROH depots.

**Category C**: unloadable BOXN wagons requiring very heavy repair on body/floor. These may be attended in wagon depots nominated for Category C repairs or in workshops.

**Note** : unloadable BOXN wagons in the age-group of 12-18 yrs. may be taken up for upgraded rehabilitation (BOXNR) as per RDSO's document No. WD-16-BOXNR-2010 of Sep. 2010.

JE/SSE(C&W) shall do the classification /marking of the wagons under the above 3 categories in open line. For booking the wagon to workshop for category C repairs, prior approval of CRSE(Fr.) should be taken. In case the Category C repairs are arising on account of damages during loading/unloading, a report should be sent by the SSE(C&W) of the depot where the damages are detected to the Sr.DME(C&W) of the division as well as Sr.DME(C&W) where the damages are occurring.

BOXN wagons of 8-22 yrs. of age, which are heavily corroded or have extensive body repairs, may be selected for rehabilitation. During rehabilitation, wagon should also undergo POH and return date should be marked accordingly. All such rehabilitated wagons should be painted with golden yellow for easy identification.

BOXN C category wagons which are sent to workshop as NPOH with prior approval of CRSE(Fr.) , and which are not taken up for rehabilitation, should be given POH in case its POH is due within next 12 months. Similarly, such wagons which are falling due for ROH within next 6 months (but not due for POH within next 12 months) should be given ROH attention. Wagons so attended for POH/ROH should be stencilled with a fresh return date as per laid down periodicity for BOXN wagons.

The repair of BOXN wagons should be carried out as per instructions contained in RDSO's G-70."

## 205. CONDEMNATION OF WAGONS

For condemnation of rolling stock, the powers delegated to various officers on zonal railways through their Schedule of Powers may be used.

### a) Condemnation of over-age wagons

Over aged wagon stock can be inspected personally by CWM/Dy. CME/WM-Incharge/Sr.DME and condition report prepared and personally signed. Condemnation can be approved by any of these officers.

### Codal life of wagon stock:

[ Railway Board's letter No.2004/M(N)951/2 Dated 26.05.2006 ]

SN	Type of wagon stock	Codal life
01	Open bogie wagon with air brake & CASNUB bogie	30 Years
02	Bogie Tank wagon with air brake & CASNUB bogie	40 Years
03	All other type of bogie wagons with air brake & CASNUB Bogie.	35 Years

**Certain issues have been clarified in Railway Board's letter No. 2007/M(N)/60/7 dated 21.10.2010. The same are summarised below:-**

### b) Condemnation of under-age wagons

Under aged wagon stock should be inspected personally by CWM/Dy.CME/WM-Incharge/Sr.DME and condition report prepared and personally signed. Condemnation proposals should be sent to CME/CRSE for approval duly concurred by associated finance i.e., WAO of the workshop concerned, further this proposal to expedite the whole process, following procedure to be adopted:-

BG and MG wagons should be condemned on 'as is where is' basis and moved from division to the yards/stations nominated by DRMs. Each DRM should nominate sufficient number of yards/stations on their division for disposal of condemned wagons. Workshops can continue the present practice of sending the wagons to scrap yards.

### Policy for Pre-Mature Condemnation of Wagons:

Board (MM & FC) have approved the following policy for pre-mature condemnation of the wagons vides Rly. Boards letter No 2007/M(N)/60/7 dated 21.10.2010.

SN	Category of wagons	Competence for approving premature condemnation
01	All accident damaged wagons & Vacuum brake stock	CMEs
02	Non Accident Air Brake Stock of morethan 25 years of age	CMEs with FA&CAOs concurrence
03	Non Accident Air Brake Stock of the age of 25 Years or less	Railway Board ( In this case, the proposal should be duly vetted by FA&CAO and approved by GM).

Board's approval will normally be granted within 90 days from the date of receipt of proposal, in case the boards approval is not received within this time limit, the proposal will be deemed to have been approved and Railway may go ahead with the condemnation. The above policy does not restrict premature condemnation of any specific type of wagons permitted under specific instructions from the Railway Board.

**c) Use of Over-aged/ Condemnable Wagons for Departmental Purposes****(Ref: Rly. Board's letter No. 2007/M(N)/951/5 dated 11.11.2011)**

Overaged/ condemnable wagons which no longer remain unusable as traffic wagons, may be used for departmental purpose, with or without modifications, subject to the following provisions:

- i. Overaged/ condemnable wagons may be used for departmental purpose with the approval of authority competent for condemnation of such wagons.
- ii. In case departmental use requires modifications to be carried out on the wagons, such modifications should, invariably, have approval of RDSO except in cases where such modified wagons are pre-existing. For pre-existing modifications, approval of CME will be necessary.
- iii. Wagon modification work shall be carried out only at a POH workshop or at an open line wagon depot maintained by the CME.
- iv. Wagon selected for departmental use should provide service of minimum one POH cycle with prescribed preventive maintenance. The POH periodicity of such stock shall be same as the original wagon type.
- v. Departmental wagons may be used upto an age limit of 40 years on condition basis. The condition of such stock shall be reviewed in every ROH and POH to assess its suitability for continuity in service based on the extent safety norms.
- vi. In case it becomes necessary for any departmental stock to continue in service beyond age of 40 yrs., CME may extend the life of such stock, maximum one year (financial year) at a time upto an age limit of maximum 50 years. The annual condition reports of such wagons prepared by in-charge by base wagon depot, duly endorsed by the coordinating branch officer of Mechanical and the user department shall be put up to CME for approval prior to commencement of the financial year. Standard maintenance shall be carried out on such wagons during the period of extended life as per prescribed periodicity and all safety norms will be observed.
- vii. No departmental wagon shall be permitted to be in service beyond the age limit of 50 years.



**206. POH & ROH INTERVAL**

**TABLE No. 2.1**  
**POH INTERVAL OF AIR BRAKE STOCK**

Sr. No.	Wagon Stock	POH (Years)	
		First	Subsequent
01	BOXN, BOXNHS, BOXNHA, BOXNCR, BOXNHL	6	4.5
02	BOXNR	4.5	4.5
03	BCN, BCNA, BCNAHS, BCNHL	6	6
04	BOST, BOSTHS, BOSTHSM2	6	4.5
05	BRN, BRNA, BRNAHS, BRN22.9, BFNS, BRHNEHS, BLC-A, BLC-B, BLL-A, BLL-B	6	4.5
06	BLCAM/BLCBM	6	4.5
07	BFKN (Container)	4	3.5
08	BOY	3	3
09	BTPH	4.5	4.5
10	BTPN	6	6
11	BOBR & BOBRN, BOBYN	6	6
12	BTPGLN, BTCS	4	4
13	BTALN, BTALNM	4.5	4.5
14	BOXNLW Stainless steel wagons	6	6
15	BOXNEL, / BOYEL (25 t axle load)	3	3
16	BOBRNEL, BOBSNM1	3	3
17	BVZI, BVZC Brake van	2	2
18	BVCM Brake van	2	2
19	BOMN	6	4.5
20	BRSTN, BWTB	6	6
21	BCACM, BCACBM	4.5	4.5
22	BTFLN, BTOH	6	6
23	BCFC	6	4.5
24	BCCNR	6	6
25	BAFRDR	6	4.5

**Note:**

1. Wagons become due POH on the last date of the month indicated in the return date.
2. Empty wagon will be marked sick for POH up to 30 days in advance of the due date
3. Loaded wagons will be allowed up to 30 days after the due date of POH.

**TABLE 2.2**  
**ROH INTERVAL OF WAGONS**

Sr. No.	Wagon Stock	ROH (Months)		
		First ROH	Subsequent ROH of First POH Cycle	ROH of Subsequent POH Cycle
1.	BOXN, BOXNHS, BOXNHA, BOXNCR, BOXNR	18	18	18
2.	BOXNHL	24	24	18
3.	BOST, BOSTHS, BOSTHSM2	18	18	18
4.	BLCAM/BLCBM, BLLA, BLLB, BLC-A/BLC-B	24	18	18
5.	BFKN (Container)	18	18	18
6.	BCN, BCNAHS, BCNA, BCNHL	24	24	24
7.	BCCNR	24	24	24
8.	BOXNLW	24	24	24
9.	BRN, BRNA, BRNAHS, BRN22.9, BFNS, BRHNEHS,	18	18	18
10.	BOBR, BOBRN, BOBRNEL, BOBSNM1	24	24	24
11.	BTPN, BTPH, BTALN, BTAL, BTFLN, BTOH, BTALNM	18	18	18
12.	BTCS, BTPGLN	24	24	24
13.	BOY	18	18	18
14.	BOBYN	24	24	24
15.	BOXNEL, BOYEL	12	12	12
16.	BVZI, BVZC, BVCM Brake Van	12	12	12
17.	BOMN, BRSTN, BWTB	24	24	24
18.	BCACM, BCACBM	18	18	18
19.	BCFC	18	18	18
20.	BAFRDR	18	18	18

### 207. WORK AREAS WHERE ATTENTION TO BE GIVEN

Table 2.3 summarises the nature of work to be done during various examinations and repairs in sickline. It is clarified that activities shown under sick line are the one's which can be under taken in sickline based on the need. These are not to be carried out on each and every wagon visiting sickline.

# **WORK AREAS**

# **WHERE ATTENTION**

# **TO BE GIVEN**

**TABLE 2.3**  
**WORK AREAS WHERE ATTENTION TO BE GIVEN**

Sr. No.	Nature of Repairs		Repairs to be under taken at X			
			Intensive repairs	Sick lines	ROH	POH
1.	<b>BODY REPAIR WORK (Common for all)</b>					
	<b>UNDERFRAME- Sole Bar</b>					
	Scrap the portion of sole bar at door ways, clean and apply primer paint followed by Top coat		-	-	X	X
	<b>SIDE WALL- Skirting</b>					
	1. Check and patch if corroded then apply primer and top coat on the patch		-	X	X	X
	2. Side Doors- Check damage and repair clean & lubricate hinges		X	X	X	X
	3. Side Pillars- Check cracks at the base & repair		-	X	X	X
	4. Patching of body, roof, door or floor plates straightening bulged ends repairs to angle irons, stanchions and crib angles etc.		-	X	X	X
	5. Making wagons water-tight (Covered wagons)		-	X	X	X
	6. Fitting/replacement of door fastening road, door cotter pin eye, bolt hook and eye locking pin on empty wagons and closing of doors.		X	X	X	X
	7. Fitting/replacement of door fastening rod guide, door hasp which requires riveting on empty wagons. Repairs by welding to door fittings.		-	X	X	X
	8. Hand rail/foot board deficient/or damaged, insecurely fastened at door way of guard's brake van		X	X	X	X
2.	<b>UNDER GEAR REPAIR WORK ( Common for all )</b>					
	Brake Linkage- Check free movement		X	X	X	X
	Hand Brake - Check proper working		X	X	X	X
3.	<b>BOGIE REPAIR WORKS</b>					
	<b>A. CASNUB BOGIE</b>					
	<b>BOLSTER</b>					
	1. Pocket slope liner	Change liner if thickness less than 5 mm	-	-	X	X
	2. Rotation stop lugs	Provide liners (thickness to suit) if dimensions less than 514 mm	-	-	X	X
	3. Inner Column Gib	Provide liners (thickness to suit) if dimension more than 142 mm	-	-	X	X
	4. Land surface	Provide liners (thickness to suit) if dimension less than 442 mm	-	-	X	X
	5. Outer Column Gib	Renew by welding if dimension more than 241 mm	-	-	X	X

Sr. No.	Nature of Repairs		Repairs to be under taken at X			
			Intensive repairs	Sick lines	ROH	POH
	<b>SIDE FRAME</b>					
	1. Column Friction Liner	Change liner if dimension more than 455 mm	-	-	X	X
	2. Column sides	Provide liners (thickness to suit) if dimension less than 209 mm	-	-	X	X
	3. Anti rotation lugs	Provide liners (thickness to suit) if dimension more than 526 mm	-	-	X	X
	4. Key seat to pad 22 W	Provide liners (thickness to suit) if dimension more than 276 mm	-	-	X	X
	5. Crown Roof 22WM	Provide liners (thickness to suit) if dimension more than 321 mm	-	-	X	X
	6. Crown Roof 22NL	Provide liners (thickness to suit) if dimension more than 326 mm	-	-	X	X
	7. Pedestal Crown Sides	Renew by welding if dimension less than 147 mm	-	-	X	X
	8. Pedestal Jaw 22 W	Provide liners (thickness to suit) if dimension more than 275 mm	-	-	X	X
	9. Pedestal Jaw 22 WM	Provide liners (thickness to suit) if dimension more than 283 mm	-	-	X	X
	10. Pedestal Jaw 22 NL(Short)	Provide liners (thickness to suit) if dimension more than 195 mm	-	-	X	X
	11. Pedestal Jaw 22 NL(Long)	Provide liners (thickness to suit) if dimension more than 241 mm	-	-	X	X
	12. Pedestal Sides 22 W	Provide liners (thickness to suit) if dimension less than 102 mm	-	-	X	X
	13. Pedestal Sides 22 WM	Provide liners (thickness to suit) if dimension less than 102 mm	-	-	X	X
	14. Pedestal Side 22 NL	Provide liners (thickness to suit) if dimension less than 78 mm	-	-	X	X
	<b>WEDGE</b>					
	1. Slope Surface	Replace the Wedge if slope surface wear is 3 mm	-	-	X	X
	2. Vertical Surface	Vertical surface from centre line of spigot wear limit: 54 mm Reclaim the worn surface by welding.	-	X	X	X
	<b>CENTRE PIVOT (BOTTOM)</b>					
	1. Vertical Side 22 W	Renew by welding if wear more than 4 mm	-	-	X	X
	2. Vertical Side 22 WM	Renew by welding if wear more than 3 mm	-	-	X	X
	3. Vertical Side 22 NL	Renew by welding if wear more than 3 mm	-	-	X	X
	4. Seat Side 22 W	Renew by welding if wear more than 3 mm	-	-	X	X
	5. Seat Side 22WM	Renew by welding if wear more than 3 mm	-	-	X	X
	6. Seat Side 22 NL	Renew by welding if wear more than 3 mm	-	-	X	X

Sr. No.	Nature of Repairs		Repairs to be under taken at X			
			Intensive repairs	Sick lines	ROH	POH
	<b>COIL SPRING</b>					
	1. Outer	Group and use in sets. Replace if free height at or less than 245 mm	-	X	X	X
	2. Inner	Group and use in sets. Replace if free height less than 247 mm	-	X	X	X
	3. Snubber	Group and use in sets. Replace if free height less than 279 mm	-	X	X	X
	<b>ADAPTER</b>		-	-	X	X
	Crown Surface	Replace if worn 3.5 mm or more	-	-	X	X
	Side lug	Replace if wear more than 3 mm on either side	-	-	X	X
	Thrust shoulder	Replace if depth exceeds 0.7 mm	-	-	X	X
	Machined relief	Replace if depth less than 0.8 mm	-	-	X	X
	<b>BOGIE BRAKE GEAR</b>					
	Pins & Bushes	Change if clearance more than 1.5 mm	X	X	X	X
4.	<b>AIR BRAKE SYSTEM</b>					
	<b>Distributor Valve</b>	<b>Overhauling</b>	-	-	-	X
	Distributor Valve	Test on SWTR	-	X	X	X
	DV Isolating Cock	Examine operation	X	X	X	X
	DV Release valve	Examine operation	X	X	X	X
	DV Filter	Clean	-	-	X	X
	<b>BRAKE CYLINDER</b>					
	Filter of Escorts & RPIL make	Clean	-	-	X	X
	Brake Cylinder of Greysham & WSF make	Lubricate	-	-	X	X
	<b>CUT OFF ANGLE COCK</b>					
	Angle cock	Examine and lubricate	X	X	X	X

Sr. No.	Nature of Repairs		Repairs to be under taken at X			
			Intensive repairs	Sick lines	ROH	POH
	Rubber Seals	Change	-	-	X	X
	<b>DIRT COLLECTOR</b>		-	-	-	-
	Dirt Collector	Clean	-	X	X	X
	Sealing Ring	Change	-	-	X	X
	<b>RESERVOIR</b>					
	AR & CR	Drain	-	X	X	X
	Sealing Ring	Change	-	-	X	X
	<b>METAL PIPES &amp; JOINTS</b>					
	Pipe Joints	Examine leakage & repair	X	X	X	X
	Seals (20 mm & 32 mm)pipe	Change	X	X	X	X
	Guard's Emergency Brake Valve	Examine operation	X	X	X	X
	Isolating cock of BVZC Brake Van	-do-	X	X	X	X
	Quick Coupling	-do-	X	X	X	X
	Load Sensing Device	-do-	-	X	X	X
<b>5.</b>	<b>SLACK ADJUSTER ( COMMON FOR ALL)</b>					
	Slack Adjuster	Test Functioning, repair if required	X	X	X	X
	“A” dimension	Adjust	X	X	X	X
	“e” dimension	Adjust	-	X	X	X
	M20 Anchor Pin nut	Ensure securing by welding to pin	-	X	X	X
	Air Brake System	Test on SWTR as per procedure	-	X	X	X
	Brake Block	Ensure Std. Key, Spilt pin & all new brake blocks	X	X	X	X
	NB: For detailed main procedure refer RDSO manual G-97.					

Sr. No.	Nature of Repairs		Repairs to be under taken at X			
			Intensive repairs	Sick lines	ROH	POH
<b>6.</b>	<b>CENTRE BUFFER COUPLER ( COMMON FOR ALL)</b>					
	<b>CBC BODY</b>					
	Coupler Body	Examine & replace on condition basis	-	X	X	X
	CBC Contour	Examine, replace if required	-	X	X	X
	Shank Wear Plate	Replace on condition	-	X	X	X
	<b>KNUCKLE</b>					
	Nose	Replace if wear more than 9.5 mm with HTE knuckle	X	X	X	X
	Knuckle pin	Replace on condition	X	X	X	X
	Knuckle Stretch	Examine, Replace if required	-	-	X	X
	<b>STRIKER CASTING</b>					
	Wear Plate	Replace	-	-	X	X
	Striker casting	Replace on condition	-	-	X	X
	<b>COUPLER MECHANISM</b>					
	Anti Creep Protection	Examine and repair	X	X	X	X
	Lock lift assembly	Examine	X	X	X	X
	Operation Mechanism	Examine	X	X	X	X
	Lock	Examine	-	X	X	X
	<b>DRAFT GEAR</b>					
	Slack	Measure & take correction	-	-	X	X
	<b>GENERAL</b>					
	Yoke pin support	Replace on condition	-	X	X	X
	Buffer Height	Examine & Correct if required	X	X	X	X
	<b>NB:</b> 1. For detailed maintenance Practices in open line refer RDSO's Manual G-76 2. For detailed maintenance Practices in Workshop refer RDSO's Manual G-80 3. Knuckle with nose more than 4.3 mm and less than 9.0 mm can be used in yard.					



Sr. No.	Nature of Repairs		Repairs to be under taken at X			
			Intensive repairs	Sick lines	ROH	POH
7.	<b>WHEEL AXLE &amp; BEARING ( COMMON FOR ALL)</b>					
	<b>AXLE</b>					
	Ultrasonic Testing	(If wheel is changed) To be carried in every ROH/POH & reject if fails	-	-	X	X
	Deep Notches due to gearing of pull rod	Reject if depth is more than 5 mm	X	X	X	X
	Axle end holes	Clean and lubricate in case end cover is opened	-	X	X	X
	<b>WHEEL</b>					
	Tread profile	Check with tyre defect gauge	X	X	X	X
	Height of flange	If height more than 31 mm do not use under ROH wagon	-	-	X	X
	Smooth flange	If flange not completely smooth do not use under ROH wagon	-	-	X	X
	Wheel profile	Turn to WWP if above clauses are not met for use under ROH wagon.	-	X	X	X
	<b>BEARING TAPERED CARTRIDGE</b>					
	Cup	Rotate the bearing for unusual sound check up for Crack/chipping	-	-	X	X
	Seal	Check seal for external damage/dent	-	X	X	X
	Backing Ring	Check backing ring for looseness & vent fitting on backing ring with vent hole ( the vent fitting should be intact or the vent hole should be plugged)	-	-	X	X
	Locking Plate	Use new locking plate when ever and cover is opened	-	-	X	X
	Axle end Cap screw	Clean and lubricate in case end cover is opened	-	-	X	X
	Load Zone Change	Change load zone area of the cup while lowering bogie side frame	-	-	X	X

### NOMINAL, ROH & MAXIMUM CLEARANCES IN CASNUB BOGIES

S. No.	Particular	Bogie Type	Measurement of Location			Total Clearance in mm			Nominal Clearance
			New/ renewed	ROH	Worn/ condemned	New	ROH	Max.	
1.	<b>Lateral clearance between Side frame&amp; Bolster</b>								
	Side frame Column sides	All bogies	216	210	206				
	Bolster column jib	W(M) & NLB bogie	234	240	244	18	30	38	18±3
		All other bogies	241	247	251	25	37	45	25±3
2.	<b>Lateral clearance between Side frame pedestal and Adapter</b>								
a)	Side frame pedestal sides	W(M), LCCF Bogie	105	102	101	25	32	35	25+3/-0
	Adapter sides	Wide Jaw Adapter	130	134	136				
b)	Side frame pedestal sides	All Narrow Jaw Bogies	81	78	77	16	23	26	16+6/-1.5
	Adapter sides	Narrow Jaw Adapter	97	101	103				
3.	<b>Lateral clearance between Side frame crown and Adapter</b>								
a)	Side frame Crown sides	W(M) Bogie	152	147	144	4	15	20	4+/-0
	Adapter crown	Wide Jaw Adapter	156	162	164				
b)	Side frame Crown sides	All Narrow Jaw Bogies	152	147	144	3.5	14.5	19.5	3.5+/-0
	Adapter Crown	Narrow Jaw Adapter	155.5	161.5	163.5				
4.	<b>Longitudinal clearance between Side frame pedestal and Adapter</b>								
a)	Side frame Pedestal jaw	W(M), LCCF Bogie	278	283	286	10	19	24	10+5/-0
	Adapter sides	Wide Jaw Adapter	268	264	262				
b)	Side frame Pedestal jaw	All Narrow Jaw Bogies	190	195	198	9	18	23	9+2/-3
	Adapter sides	Narrow Jaw Adapter	181	177	175				
5.	<b>Longitudinal clearance between Side frame column and Bolster land surface</b>								
	Side frame column	All bogies	450	455	458	6	14	20	6+/-0
	Bolster land surface	All bogies	444	441	438				
6.	<b>Clearance between Side frame anti-rotation lug Bolster rotation stop lug</b>								
	Anti- rotation lugs	All bogies	522	526	528	4	12	16	4+3/-0
	Bolster rotation stop lugs	All bogies	518	514	512				
<b>NOTE: Nominal clearances given above are sum of both sides. For other details please refer G-95.</b>									



*( MAINTENANCE MANUAL FOR WAGONS- 2015 )*

# CHAPTER – 3



# YARD MAINTENANCE



## CHAPTER 3

### YARD MAINTENANCE

The efficient working of freight stock is closely linked to the standard of yard maintenance. Several factors are responsible for good and quality examination/repairs in the yard. The method of examination is described in the succeeding paragraphs.

#### **301. NOTIFICATION OF EXAMINATION POINTS:**

Railways should notify the nodal examination points authorised to issue brake power certificates for running of air brake trains on End-to-End, Premium Examination and Close Circuits patterns. These nodal points should have adequate facilities like cemented pathways, welding points, proper lighting etc. for proper examination of air brake trains. The BPC shall be issued only from these nodal examination points.

#### **302. PATTERN OF FREIGHT TRAIN EXAMINATION:**

*The important instructions for the examination of freight trains and issue of BPC are summarised below :*

##### **1. END TO END EXAMINATION**

The rake should normally be intensively examined in empty condition except when back loading of rake has to be done at stations/sidings. After such intensive examination, the empty rake should be moved to the loading station as per the requirement of traffic.

- i) The BPC of empty rake may have no destination mentioned. However, after loading the empty rake, the operating staff (commercial staff, if operating staff is not posted at that station) will ensure that the destination of the loaded train is clearly mentioned on the BPC and the same BPC will then become valid upto such destination.
- ii) No Loco pilot should move the loaded train from the loading point unless the destination is clearly mentioned on the BPC. BPC of the loaded train without destination will be considered as invalid.
- iii) At the destination, after unloading, the rake must be examined once again in the empty condition and the above cycle repeats. In the absence of freight train examination facilities at the unloading point, the empty rake/back loaded rake must be examined at the first freight train examination point in the direction of movement. The movement of empty rake/back loaded rake from the unloading point to the first freight train examination point will be permitted on Loco pilot and Guard's certificate for which the instructions given at **303** shall be followed.

**The End-to-End BPC shall remain valid provided:**

- i. The destination is mentioned on the BPC of the loaded train.
- ii. Rake Integrity is not disturbed by more than **04** wagons (in case of BLCA/BLCB, the maximum limit of wagons which can be detached/replaced during run are **05**, i.e. 01 unit = 05 wagons) and intensively examined wagons given fitness by train examining staff may be attached as replacement.

**BACK LOADING OF TRAINS:**

When back loading is done at a station where freight train examination facilities exist, the loaded rake should be examined at that station only and BPC issued. In cases where back loading is done at a non-TXR station, such trains can be:

- a) Either checked by flying squad, if operationally feasible.
- b) Or, if it is not possible, permitted to run on a Guard & Loco pilot's memo for which the instructions given at para **303** should be followed.

Running of trains on Loco pilot's and Guard's memo, will be permitted only up to the first freight train examination point in the direction of train movement.

**2. PREMIUM EXAMINATION**

The BPC of premium rakes shall have a validity of 12 days with 3 days additional grace period to facilitate examination in unloaded condition. The following stamp shall be provided on the BPC of Premium rakes:

**This BPC is valid upto .....(mention date)  
 After this date NO FRESH LOADING IS PERMITTED  
 (3 days grace period after this date is allowed for rakes loaded  
 upto above date)**

**The following conditions have been prescribed for Premium rakes (vide Bd's letter No. 2005/ M(N)/951/13 dated 07/10. 04.2006) :**

- I. Premium end to end rakes will be intensively examined in empty condition and certified by examination points nominated by CME & COM. Such premium examination points should either be 'A' category or upgraded to 'A' Category examination point.
- II. If any of the conditions, i.e. examination in empty condition or examination at nominated points is not satisfied, rake will not be certified as premium rake and will operate as normal end to end rake.
- III. Brake Power Certificate issued for such premium end to end rakes will be valid for 12 days from the date of issue. During this 12 day period, the rakes will be allowed for multiple loading / unloading.
- IV. After each loading / unloading, the rake will be examined by Guard and Loco pilot before commencement of journey and observations will be recorded under the

relevant columns of the Brake Power Certificate. In case of mechanized loading/unloading, examination by TXR is desirable.

- V. The rakes will be turned out with minimum 95% Brake Power.
- VI. After the completion of 12 days, the rakes should be offered for next intensive examination at the first examination point in the direction of movement. To avoid examination in loaded condition, a grace period of 3 days shall be permitted. However, after expiry of the grace period, i.e. after completion of 15 days after the date of issue of BPC, even a loaded premium rake shall be offered for examination at the first TXR point in the direction of movement. Further, in no case, Premium rakes shall be offered for loading through bypass routes or through yards which are not nominated for examination. After examination, the rake will be certified as premium rake subject to fulfillment of above mentioned conditions, otherwise as conventional end to end rake.
- VII. Movement of Premium rakes will be monitored thorough FOIS by Traffic and Mechanical departments.
- VIII. The format for Brake Power Certificate for Premium end to end rakes (to be printed on good quality **green colour** paper) is enclosed at **para 315**.

**3. Close Circuit Rakes Examination**

Railway must ensure that the infrastructural facilities at all the CC examination points are upgraded to ‘A’ category.

- (a) As far as possible, the close circuit air brake rakes should be formed from off-ROH and off-POH wagons.
- (b) The complete history of wagon and its components, i. e. Bogie, Draft gear, Coupler, AB System, Wheel & CTRB, etc. should be maintained by the Base Depot.
- (c) The **Originating Brake Power** for air braked goods trains running **in close circuit, shall be 100 %** with adequate brake block thickness
- (d) Further, Zonal Railways shall maintain detailed record w.r.t. enroute detachments, brake power and detachments during examination of these rakes.

The BPC of CC rakes shall be valid for 6000/7500 Kms or 30 days + 5 days, whichever is earlier. Grace period of 5 days is allowed if **the rake is moving towards the base depot**. The following stamp shall be provided on the BPC of CC rakes:

**This BPC is valid up to .....(mention date)**  
**After this date NO FRESH LOADING IS PERMITTED**  
**(5 days grace period after this date is allowed if the rake is moving towards the base depot)**

- e) The BPC of CC Rake issued at the nodal point shall remain valid provided:
  - i. The kilometrage have been logged in correctly and continuously (if not, the BPC will be deemed to be valid for 20 days only from the date of issue). It is the responsibility of the crew to check that entries regarding distance are clearly and continuously recorded.

- ii. The rake integrity is not changed and only the listed wagons are included.
- iii. The rake is running in the predefined circuit only as mentioned on the BPC.  
(Breaking the rake into parts and reforming the same parts, will not be deemed to have broken the rake integrity).

No intermediate examination of the Close Circuit rake is required. It would be the responsibility of the Loco pilot and Guard to check the unloaded CC rake at the unloading point and ensure brake continuity before starting.

- f) **Normally, all Close Circuit freight trains should be given intensive examination during day light hours. However, if Close Circuit freight trains are examined during night hours, minimum illumination level of 100 to 150 Lux is required for under gear examination as well as repair work of rake.**
- g) BPC issued after thorough freight examination in empty condition must be revalidated after loading. Revalidation includes conducting brake continuity test, ensuring completeness/securing of brake gears and endorsing on intensive BPC. No wagons shall be detached from the rake unless safety is affected.

**CC rakes shall be subject to the following conditions:**

- I. CC Rakes should be maintained in the examination yards which have No line of OHE Passing over the maintenance lines.
- II. CC rakes shall be monitored closely through FOIS by all Sr. DOMs to ensure that these rakes are worked to their respective base depots before completion of stipulated KMs/ days. Rakes with invalid BPC shall normally not to be permitted to run in service.
- III. All the cases of violation of this limit shall be analyzed by the concerned Division / Zone where such rake gets detected, either on run or during subsequent examination, for adequate corrective and/ or preventive action (if necessary).
- IV. In case Km / Days limit is breached due to lack of monitoring or otherwise, and the rake is in empty condition, it shall be pushed to nearest TXR point for Revalidation and endorsement on BPC by TXR that the train is safe to run up to the base depot.
- V. Such potentially unsafe rakes mentioned under (g) above, when detected in loaded condition, shall be subjected to GDR check and pushed to destination. After unloading, the empty rake shall be offered to the nearest TXR point for Revalidation and endorsement on BPC by TXR that the train is safe to run in empty condition upto its nominated base depot.
- VI. The potentially unsafe rakes from the point of detection to the nearest TXR point, will move on GDR check.



#### 4. POST LOADING AND POST TIPLING EXAMINATION

[ Reference Railway Board's letter No. 2005/ M (N)/ 951/ 13 dated 08.02.2006 and letter No. 98/ M(N)/ 951/ 12/ Pt. 1 dated 17.05.07 ]

- a) After tipping, the rake should be subjected to post-tipping check either by TXR staff or by Guard and Loco pilot in case of non-provision of TXR staff in the siding.
- b) As local condition may vary from siding to siding, based on recommendations of CME & COM, GMs may decide whether the post-tipping check on a particular point will be entrusted to TXR staff or Guard & Loco pilot. While deciding the matter one way or other, the following may be kept in mind:-  
Recovery of necessary charges from the owners of such sidings in case of any defects / damages are noticed.
- c) Post tipping check by Guard & Driver should be done as per format given at **para 303**.
- d) Rules regarding starting of trains from non-TXR points after examination by Guard and Loco pilot should be strictly enforced.

#### 5. GDR CHECK

- I. GDR check should be done for post loading/back loading of a rake.
- II. After tipping, the rake will be subjected to post-tipping examination and the check may be carried out by Guard & Loco pilot.
- III. If BPC has become invalid then GDR Check should be done before taking the rake to the nearest train examination point in the direction of movement.
- IV. In case of the Attachment/detachment of the wagon, or reversal of power at Non-TXR point, continuity of the Brake pipe pressure must be ensured by Loco pilot & Guard.

#### 303. Guidelines for GDR Check

(Railway Board's Letter No. 2002/M(N)/204/10 Vol.I dated 30.07.2009)

**All CBCs couplings are coupled and it should also be ensured that CBCs are locked and the operating handle properly set in the slot.**

- a. All Air hoses pipes are properly coupled and secured.
- b. Air hose at the end of train is properly placed on air hose carrier.(stand)
- c. All the angle cocks are in open condition except for the angle cock at the end of the train which is in closed condition.
- d. Empty/Load device handles are kept in the correct position on loaded/empty rakes.
- e. Numbers of dummy/in-operative cylinders are not exceeding the limits prescribed.
- f. There are no loose fittings/hanging parts like pull rod, brake beam, safety brackets and brake blocks, etc. which endanger safe running of the train.
- g. All hand brake levers/wheels are released.

- h. It shall be ensured by the Guard that all the doors of the covered & open wagons are properly closed or secured in open condition in case of perishable/lime stone consignments.
- i. Any other abnormalities noticed are to be recorded in the BPC. Guard & Loco pilot shall prepare a memo jointly on a plain sheet in triplicate indicating the brake power and deficiencies, if any, and shall append their signatures and both of them shall retain a copy of the same.
- j. Guard should obtain SM/YM's endorsement on two copies of the joint memo and hand over the third for SM/YM's record.
- k. SM/YM will inform the section control after making the endorsement on the joint memo and obtain clearance for the train to move.
- l. Continuity of the Train pipe is confirmed through VHF/Whistle code before starting the train.
- m. Fitment of Air Brake Gauges is mandatory by Guard of the train.
- n. Ensuring that the rake is cleared with **twin pipe brake system if BPC has endorsement as twin pipe, subject to a compatible loco being attached to the train.**

### **304. General Condition for Freight Train Examination:**

- a. All freight trains should be subjected to thorough examination in empty condition at originating stations.
- b. In exceptional cases, the back loaded freight trains can be examined as per instructions mentioned in **para 302 item 1.**
- c. All freight trains shall be re-examined if stabled for more than 24 hours by SSE/JE (C&W) in yard and by Guard and Loco pilot in non C&W station up to next C&W point in the direction of movement for examination, as per Railway Board's Joint Procedure Order placed at **para 304.**
- d. Rake Integrity is not disturbed by more than **04** wagons (in case of BLCA/BLCB, the maximum limit of wagons which can be detached/replaced during run are **05** i.e. 01 unit = 05 wagons) and intensively examined wagons given fitness by train examining staff may be attached as replacement.

### **305. STEPS OF FREIGHT TRAIN EXAMINATION**

**The Freight Trains shall be subject to the following examinations:**

- a) Rolling-in / Terminating examination.
- b) Intensive examination of originating trains including repairs, detachment of damaged/sick wagons, brake testing, etc.
- c) Issue of Brake Power Certificate after ensuring brake continuity of the formed load.

**306-DETAILS OF FREIGHT EXAMINATION:****306 (A). ROLLING-IN / TERMINATING EXAMINATION**

All terminating trains should be given rolling-in examination while entering the station/yard of the train examination depot. To carry out this examination the Train Examiner and his staff should take up positions on both sides of the lines short of the normal halting place on which the train is to be received. The following inspection should be carried out during the rolling in examination:

- i. In-motion inspection and observation of under gear of wagons for any loose or dangling components and flat places on tyres/wheels.
- ii. Immediately after the train has come to a halt, all axle boxes should be felt/ temperature measurement taken with contact-less thermometers and those, which are found running at high temperature (more than 90<sup>0</sup>C), should be marked sick.
- iii. Examination of any abnormal behaviour of any of the vehicles or any other observation which may be related to the safety of the train.
- iv. The rolling-in examination must be conducted to detect any skidded wheel.
- v. Incoming BPC should be collected by the C&W staff.

**306-B. FREIGHT TRAIN EXAMINATION AND REPAIRS -**

Once, the train has been offered for examination by Traffic Department, the rake should be protected at both the ends before undertaking the maintenance. IRCA Part-III shall be referred during examination.

The following examination and repair activities shall be carried out:

- i. Inspection and repairs of running gear fittings.
- ii. Inspection and repairs of brake gear and spring gears.
- iii. Inspection and repairs of draw and buffing gear.
- iv. Checking and making good the deficiency of safety fittings, safety brackets, safety loops, etc.
- v. Replacement of brake blocks:
  - Brake blocks should be replaced on reaching condemning thickness as given in para **308 A**.
  - To ensure correct fitment of brake blocks, only spring steel key as per RDSO Drg. No. W/BG-6150 should only be used.
  - After fitment of brake block and key on brake head fitment of split pin should be ensured.
- vi. Correct fitment of washers, bulb cotters and all brake gear pins to be ensured.
- vii. Correct functioning and positioning of empty load device.
- viii. Checking and proper securing of doors of covered wagons.

- ix. Look for abnormal and /or unequal CBC height, Wear plate, Knuckle, etc. to the extent possible by visual examination. In case of doubt, the CBC height should be measured.
- x. Meticulous check of brake cylinders, distributor valves, auxiliary reservoir control chambers and other pipe points should be carried out to ensure that these are in proper working order. Isolating cocks and angle cocks to be checked for proper position. Brake cylinder should be released and checked for piston stroke as per para **308 B** for empty and loaded position.
- xi. After brakes are released, the wheel profile should be examined visually. If any defect is noticed, it should be checked with tyre defect gauge and wagon to be marked sick for wheel changing, if required. If bent axle is suspected wheel gauging must be done.
- xii. The bogies, complete side frames and bolsters are to be visually examined for cracks and missing parts. Bolster springs, snubbers, spigots, centre pivots fastening, side bearer and elastomeric pads should be checked for defects, if any.
- xiii. Examine brake rigging components with special attention to brake beam deformation and wear on integral brake shoe bracket. Check intactness of the pull and push rods with pins, washers, split pins and cotters, etc. Hand brakes must be checked for smooth and effective operation.
- xiv. Visual examination of under frame members, body, door mechanism, CBC wear or deficiency of parts to be marked and their operation to be checked.
- xv. Brake power should be tested.
- xvi. Where a rejectable defect can not be attended to on the train in the yard, the wagon shall be damaged labelled for attention in the sick line.
- xvii. Brake adjustment shall be done as per wheel diameter by adjusting End Pull Rod hole position.
- xviii. Visual examination of under frame members, body, door mechanism for any defects/ damages. Attend, if necessary.

### **306C. AIR BRAKE TESTING OF RAKES HAVING SINGLE PIPE BRAKE SYSTEM :**

A rake consisting of air brake wagons should be tested with rake test rig. This rig may be used for testing the train in yard before attaching the engine. The rake test rig has compressed air supply and a mobile test rig. The mobile test rig has a cubical structure and is mounted on wheels. The following activities shall be carried out:

- i) Attach the locomotive/compressor through the test rig to the train & couple brake pipes. Ensure correct coupling with pipes so that there is no leakage of air from coupled joints
- ii) The coupling should be done with angle cocks in closed position.
- iii) Open the angle cocks of loco after coupling brake pipe.
- iv) Open the angle cock of the brake pipe on all the wagons. Check for continuity of brake pipe by reducing and rebuilding brake pipe pressure. The verification should invariably be carried out through the pressure gauge provided in Guard's Brake Van.

- v) After the brake pipe pressure has stabilised in the locomotive and rearmost vehicle, move the driver's automatic brake valve handle towards application position to reduce the brake pipe pressure from 5 kg/cm<sup>2</sup> to 4 kg/cm<sup>2</sup>
- vi) After the brake pipe pressure has been stabilised, close the brake pipe isolating cocks provided between additional C2 relay valve and brake pipe of the locomotive.
- vii) Wait for 60 seconds for temperature and gauge settlement. Then note the drop in pressure in the brake pipe gauge in the locomotive for five minutes.
- viii) The drop in brake pipe pressure gauge shall not be more than 0.25 kg/cm<sup>2</sup> per minute.
- ix) Examine for leaky components, malfunctioning of distributor valves, brake cylinders, control and auxiliary reservoirs, angle cocks, BP hoses, etc.
- x) If the leakage rate is more than the value indicated in para viii, check for excessive leakage on individual wagon as indicated below:
  - A hissing sound would be audible at points where leakage is heavy.
  - Once the hissing sound is heard from a particular area, pin point the location of leakage by applying soap water solution.
  - Use of permitted material viz. Teflon tape for arresting the leakage at threaded joints.
- xi) In case leakage is heavy and cannot be arrested, the wagon may have to be isolated/detached
- xii) In case where leakage can be arrested temporarily by tape and the nature of leakage is such that it requires attention at primary depot, clear marking on the wagon must be made to draw attention of primary depot for adequate attention.
- xiii) In case the leakage is from the distributor valve and cannot be arrested, close the distributor valve isolating cock. In such a condition, clear marking should be provided on the wagon to indicate this defect to primary depot. Do not close brake pipe angle cocks under any circumstances either for isolation of wagons or for any other purpose whatsoever except for carrying out shunting operation after which the angle cocks should again be opened to ensure continuity of brake pipe.

### **306C. AIR BRAKE TESTING OF RAKES HAVING TWIN PIPE BRAKE SYSTEM**

#### **Rake Test :**

A schematic layout of rake test rig (RTR) is shown in Fig (A). A rake of wagon stock can be tested with this Test Rig. This Rig may also be used for testing the train in yards before attaching the engine.

The Rake Test Rig unit has air supply and mobile test rig. The mobile test rig is having a cubical structure and is mounted on wheels. It can be taken to the yards and sick lines. The procedure is as follows:

- A. Carry out Visual Examination of rake.
- B. Prepare Test Rig for Rake Test.
- C. Conduct Leakage, Service Application and Release Test.

Visual inspection is a check of air brake sub-assembly for any damage on the brake pipe, hose coupling etc and then rectifying it. The steps are :-

- i) Inspect loose suspension brackets and anti-pilferage devices of all air brake sub-assemblies.
- ii) Visually inspect for any defect/damage in the brake pipe, hose pipe, coupling etc.
- iii) Rectify or replace the problematic part/sub-assembly.

Rake Test can be performed by using a portable device called 'Test Rig' or by Locomotive. The Test Rig provides all facilities like locomotive to conduct the test. The source of compressed air supply to the Test Rig is through a compressor installed in the wagon depot for Brake Pipe and Feed Pipe of the test rig. The Air Dryer should also be provided just before connecting brake pipe and feed pipe for supply of dry air.

Attach the rake test rig to the rake through the couplings. Carry out following tests as per the procedure given in G-97 Annexure-XI {MP guide No.11 (Rev.01) amendment No.01 of Jan-2010} for checking capability of locomotives for Charging/Releasing of train brakes, checking of leakage in the train, checking leakage in feed pipe, brake cylinder operative percentage, and procedure to be followed at way side.

**Note: In case rake test rig is not available testing shall be done by locomotive.**

***Following examination must be carried out before rake testing***

- Hand Brakes of all wagons are fully released.
- Operating handle of empty load box is in correct position i.e. 'Empty' position when wagon is empty or lightly loaded and in 'Loaded' position when wagon is loaded beyond the specified value.
- Hose couplings of brake pipe & feed pipe on consequent wagons are coupled to one another to form a continuous air passage from the locomotive to the rear end of train.
- All the angle cocks except those at the rear end of the train are kept OPEN.
- Hose coupling at the rear end of the train is placed on hose coupling support.
- Isolating cocks of Distributor Valve on all wagons are in OPEN position.

### **1. Checking of Continuity and Leakage in Rake:**

- A. Attach the Diesel/Electric locomotive/Test Rig to the rake fitted with twin pipe air brake system and couple brake pipes and feed pipes. Ensure correct coupling with brake and feed pipe in a manner that there is no leakage of air from coupled joints.
- B. The coupling should be done with angle cocks in closed position.
- C. Open the angle cocks of loco after coupling feed pipe and brake pipe.
- D. Open the angle cock of the brake pipes and the feed pipes on all the wagons and check for continuity and leakage of brake pipe and feed pipe by reducing and rebuilding brake pipe and feed pipe pressure operating by A9 brake valve & angle cock fitted in feed pipe on locomotive (on wagon side) respectively. The verification should invariably to be carried out through the pressure gauges (BP& FP) provided in Guard's Brake Van.

**Brake Pipe pressure in train (kg/cm<sup>2</sup>)**

S. N.	Length of the train	RTR/Locomotive	Brake Van
1	UP TO 56 BOXN WAGONS	5.0	4.8
2	BEYOND 56 BOXN WAGONS	5.0	4.7

**Feed Pipe pressure in train (kg/cm<sup>2</sup>)**

S.N.	Length of the train	RTR/Locomotive	Brake Van
1	UP TO 56 BOXN WAGONS	6.0	5.8
2	BEYOND 56 BOXN WAGONS	6.0	5.7

**NOTE:** If the pressure is not within specified limit as given above then check for leakage in rake and correct it.

**Leakage Rate Test:**

- E. After the stabilizing pressure as given in above table, move the driver's automatic brake valve handle (A-9) towards application position to reduce brake pipe pressure from 5.0 kg/cm<sup>2</sup> to 4.0 kg/cm<sup>2</sup>.
- F. After the brake pipe pressure has been stabilized –
  - i) Close the brake pipe isolating cock provided between additional C2W Relay valve and brake pipe of the locomotive or isolating cock of Test Rig for checking BP leakage.
  - ii) Close the isolating cock provided between feed valve and feed pipe of the locomotive or isolating cock of FP for checking FP leakage.
- G. Wait for 60 sec for temperature and gauge settlement then note the drop in pressure in brake pipe & feed pipe pressure gauge in locomotive for 05 minutes.
- H. The drop in brake pipe & feed pipe pressure gauge shall not be more than **0.25 kg/cm<sup>2</sup>/min.**
- I. If the leakage rate is more than the value indicated in (H), check for excessive leakage on individual wagon as indicated below –
  1. A hissing sound would be audible at points where leakage is heavy.
  2. Once the hissing sound is heard from a particular area, pin-point the location of leakage by applying soap water solution.
  3. Use of permitted material viz. Teflon tape arresting the leakage.
- J. In case leakage is heavy and cannot be arrested, the wagon may have to be isolated/detached.
- K. In case where leakage can be arrested temporarily by tap and the nature of leakage is such that it requires attention at primary depot, clear marking on the wagon should be to draw attention of primary depot for adequate attention.
- L. In case the leakage is from the distributor valve and cannot be arrested, isolation of the wagon can be carried out by closing the distributor valve isolating cock. In such condition, clear marking should be provided on the wagon to indicate this defect to primary depot. Do not close brake pipe angle cocks under any circumstances, either for isolation of wagons or for any purpose whatsoever, except for carrying out shunting operation after which the angle cocks should again be opened to ensure continuity of brake pipe.

**2. Service application and Release Test:**

- A. Move the driver's automatic brake valve handle (A-9) towards service brake application position and drop the value of brake pipe pressure (BP) between **1.3 to 1.6 kg/cm<sup>2</sup>**.
- B. Brake blocks of all wagons should apply after brake application and brake blocks on wagons are mating with the wheels after brake application.
- C. Check the piston stroke of all wagons, all should be within specified limit for piston strokes for different types of wagons is given in para 308B.  
  
If the piston stroke is incorrect then, record "A" Dimension, it should be  $70 \pm 0^2$  mm in empty and loaded condition.
- D. Check all brake cylinders. Wagons with inoperative brake cylinders should be marked unfit and detached.
- E. After the release of brake, the piston of brake cylinder should fully inside and brake blocks are away from the wheels.
- F. Guard's emergency brake valve: Ensure that Guard Emergency brake valve is working properly by operating it.
- G. BPC (Brake Power Certificate): Ensure that Loco Pilot, Guard and TXR have checked the details given in the certificate and signed for its compliance.

**3. Brake cylinder operative %:**

- 1. The trains originating from primary depot should have a brake cylinder operating percentage of 100% in case of CC rake. For premium rakes, minimum originating brake power percentage is 95% and for end to end rake is 90%.
- 2. Train examination staff should check the operative percentage by observing gripping of brake blocks on wheels.

**4. Procedure to be followed at Way-Side Station:**

- 1. If the leakage rate is found more than the value indicated in 1(H), locate the source and arrest the leakage as per the procedure given in 1(I).
- 2. In case the leakage can be arrested temporarily by tape and the nature of leakage is such that it requires attention at primary depot, clear marking on the wagon should be done to draw the attention of primary depot for adequate attention.
- 3. In case the leakage is from distributor valve, follow the procedure given in 1(L).
- 4. In case the leakage is heavy and can not be arrested and wagon has to be detached, contact the control and obtain further advice.



**NOTE:1.** It is clarified that the maximum originating brake power for air braked goods trains running on end to end pattern of examination shall be **90%** except wherever local restrictions have specified higher levels of brake power to meet specific requirements. Exception shall only be made after prior personal approval of Chief Rolling Stock Engineer has been obtained for each individual.

**NOTE:2.** Whenever a rake is stabled, it must be secured properly as per rules given in G&SR of Zonal Railways.

\*\*\*

### PROFORMA FOR RAKE TEST

**Type of rake :**

**Type of Wagons :**

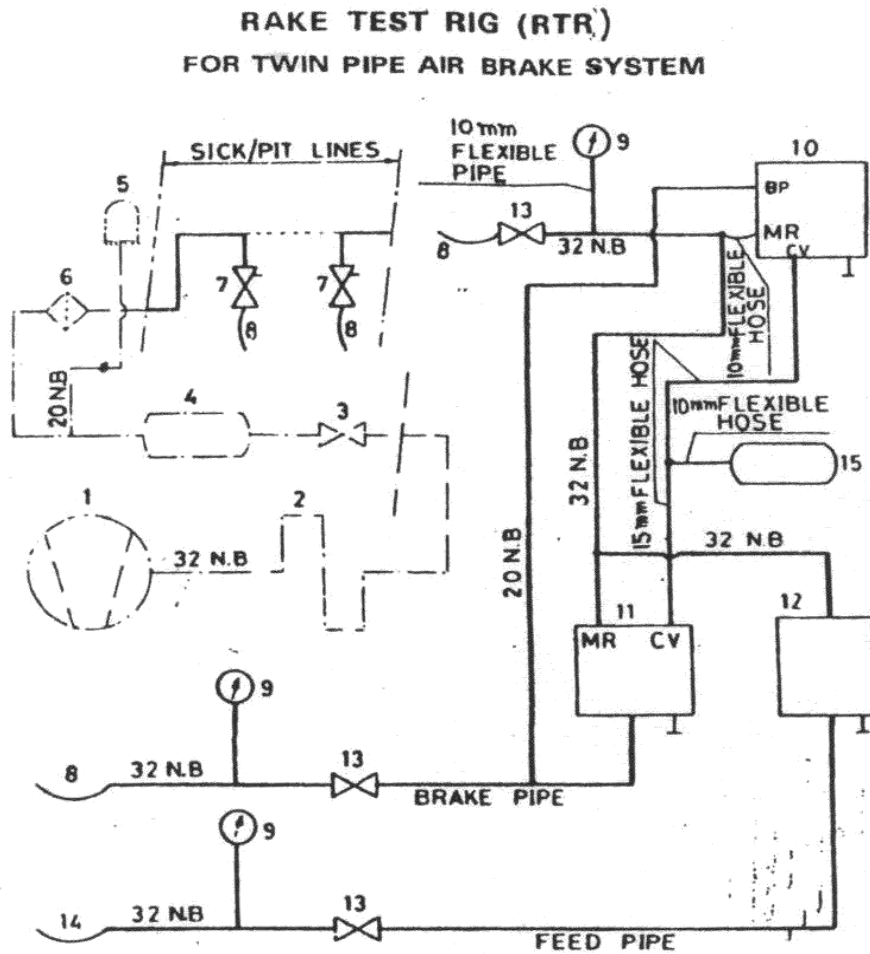
**Type of DVs :**

**BP pressure :**

**FP pressure :**

S.N.	Check	Specified	Actual
1.	<b>Pressure at last Wagon</b>		
	a) Brake pipe	Up to 56 wagons 4.8 Kg/cm <sup>2</sup> (min.) Beyond 56 wagons 4.7 Kg/cm <sup>2</sup> (min.)	
	b) Feed pipe	Up to 56 wagons 5.8 Kg/cm <sup>2</sup> (min.) Beyond 56 wagons 5.7 Kg/cm <sup>2</sup> (min.)	
2.	<b>Leakage Rate</b>		
	a) Brake pipe	0.25 Kg/cm <sup>2</sup> /min. (max.)	
	b) Feed pipe	0.25 Kg/cm <sup>2</sup> /min. (max.)	
3.	<b>Service Application and Release Test</b>		
	a) Brake application when B.P. pressure reduced between 1.3 to 1.6 Kg/cm <sup>2</sup>	Brakes should apply	
	b) Observe Piston stroke of brake cylinder	Piston in applied position and brake blocks are matting the wheels	
	c) Record the piston stroke	Piston stroke should be within specified limit.	
	d) Releasing of the brake when B.P. Pressure charge upto 5 Kg/cm <sup>2</sup>	Piston should be fully inside the brake cylinder.	
4.	Brake cylinder operating %	Trains originating from primary depot should have a brake cylinder operating percentage of 100%. <b>(In case of CC Rake)</b>	

**FIG-A**



**Note :—The equipments shown after the pit line are the parts of mobile test stand.**

Item	Description	No. off	Item	Description	No. off
1.	Compressor 2000L/min. pressure 8-10 kg/cm <sup>2</sup>	1	8.	Brake hose coupling BP	2
2.	After cooler	1	9.	Single pressure gauge 6"	3
3.	Check valve	1	10.	Driver's Brake valve	1
4.	Main reservoir 300L.	1	11.	Relay valve DU-22	1
5.	Safety valve	1	12.	Feed valve F-2	1
6.	Filter	1	13.	Isolating cock	3
7.	Angle cock	2	14.	Brake hose coupling FP	1
			15.	Equalising reservoir 9L	1

**AIR SUPPLY SYSTEM**

- This consists of a compressor (1), after cooler (2), check valve (3) main reservoir (4), safety valve (5) and filter (6). All these items are to be installed in a room in a yard.
- The compressor generates pneumatic pressure of 10 kg./cm<sup>2</sup> and compressed air is stored in main air reservoir MR(4). The safety valve (5) opens out if the pressure exceeds 10 Kg./cm<sup>2</sup>. The oil and dirt will be separated out in the filter (6). The check valve (3) prevents back flow of air while compressor is off.
- The compressed air line is connected to the pipe line in the sick line/yard. Angle cock and hose coupling (BP) are provided at various points depending upon the train formation and check points in sick line.

**MOBILE TEST RIG**

- The rig consists of brake hose coupling BP (8) and isolating cock (13) at the inlet of the mobile test rig. The air connection can be tapped from one of the points of sick-line. The mobile test rig is provided with driver's brake valve (10) and an equalizing reservoir (15).
- Brake pipe in the rake is charged while driver's brake valve (10) is kept in released and running position. The driver's brake valve inlet is connected to MR. It regulates the pressure to 5 kg./cm<sup>2</sup> through the relay valve (11). Isolating cock (13) is provided to isolate BP from driver's brake valve (10).
- The relay valve has been provided in the system for augmenting the feeding capacity of driver's brake valve. The hose coupling of BP is connected to the brake pipe coupling of the rake.
- The MR line is connected to the feed valve (12) and regulatory pressure of 6 kg/cm<sup>2</sup> is obtained from the outlet. Feed pipe in the rake will be charged through feed valve (12), isolating cock (13) and brake hose coupling FP (14).

**TOOLS AND EQUIPMENT**

- [1] Rake Test Rig/Locomotive.
- [2] Open End spanner 18x19"
- [3] Spanner 10 mm & 12 mm

### 306E. COMMON PROBLEMS IN BOGIE MOUNTED BRAKE SYSTEM AND REMEDIES

1.	<b>Brake Cylinder – Leakage</b>		
	It is observed that dust and dirt enters the brake cylinder through the flange area, hereby causing leakage of Brake cylinder. Parts of plastic cap etc. used on Pipes are found inside the cylinder body. Dirt particles mixed with grease are also found inside the Brake cylinders.		
	<b>Action by en-route operating Staff</b>	<b>Action by Depot / Workshop</b>	<b>Preventive Action</b>
Isolate the defective BC with the help of isolating cock.	Brake cylinder to be replaced and defective BC to be repaired.	<ul style="list-style-type: none"> <li>➤ The protection cap over the brake cylinder should be removed prior to its connection with hose pipe only.</li> <li>➤ Blow the BC pipeline before connecting the Brake cylinder. This can be done by making few Brake applications.</li> </ul>	
2.	<b>Brake Cylinder - Improper fitment of BC Flexible Hoses</b>		
Tighten the bolts properly to prevent leakage, else isolate the defective BC with the help of isolating cock.	Tighten the bolts properly if possible, else replace the bolts with correct size bolts.	Care should be taken to ensure that correct size of hardware is used and is properly tightened to ensure trouble free service.	
3.	<b>Brake Cylinder - Improper handling &amp; storage resulting in damage to Brake cylinder</b>		
If the outer tube is damaged and the brake cylinder is not working, Isolate the defective BC with the help of isolating cock.	Replace the Brake cylinder and the defective BC is to be repaired.	Proper care should be taken in storage & handling of brake cylinders. Use trolley for movement of wooden cases of Brake cylinder.	
If the hand brake cable is damaged, hand brake may become inoperative.	Replace the Brake cylinder and the defective BC is to be repaired.	Proper care should be taken in storage & handling of brake cylinders. Use trolley for movement of wooden cases of Brake cylinder.	
4.	<b>Brake Cylinder – Not releasing</b>		
1. Due to malfunctioning of DV. Staff should put handle of Isolating cocks to close position to vent air. Isolate the DV	Move the handle of Isolating cocks to close position to vent the air from brake cylinder. Isolate the DV by moving the R-charger handle to close position.	Repair / replace the DV.	
2. Due to malfunctioning of BC (Action by enroute staff) (Isolate the Brake Cylinder by Isolating cock)	The internal mechanism of brake cylinder is damaged. Isolate the defective BC with the help of isolating cock. It will release the air pressure from the Brake cylinder. If this doesn't work, remove the pin connecting the push rod and lever to free the system.	Replace the Brake cylinder and same to be repaired.  Re-connect the system and provide the necessary APDs.	

		Suitably tie the push rod and lever to prevent it from touching the wheel. (Is this action by W/s)	Apply brakes to adjust the system.
5.	<b>APM Device – Improper fitment</b> The bracket of APM Device is not properly fitted on the underframe, as a result, the sensor arm is not properly touching the side frame on the Bogie.		
	<b>Action by en-route operating Staff</b>	<b>Action by Depot / Workshop</b>	<b>Preventive Action</b>
	No action is possible.	The position of the bracket is to be corrected to ensure that the working of APM valve is proper.	Care should be taken during the welding of APM Device bracket on under-frame. It should be ensured that the sensor arm is correctly touching in the centre of the side frame.
6.	<b>APM Device – Improper fitment of flexible hoses</b> If the APM Device flexible hoses are not properly fitted, they can get cut / damaged.		
	Tie the flexible hose properly through some suitable means to under-frame member.	Provide suitable clamp to ensure that the flexible hose is not loosely hanging.	Care should be taken during the fitment by providing suitable clamp / bracket.
7.	<b>APM Device – Leakage from the mounting bracket connecting the pipes</b>		
	<b>Action by en-route operating Staff</b>	<b>Action by Depot / Workshop</b>	<b>Preventive Action</b>
	Tighten the bolts properly to prevent leakage.	Tighten the bolts properly if possible. In case an incorrect bolt size has been used, it could have damaged the bracket also. Bracket needs to be replaced.	Care should be taken to ensure that correct size of bolts are used and properly tightened to ensure trouble free service.
8.	<b>Missing of split pins – Brake Head Damage / Missing</b> The absence of split pin above Brake head pin can result in pin moving out. Further, this could result in dropping of brake head and thereby causing the Brake Beam to touch the wheel and get damaged.		
	Isolate the bogie by operating the isolating cock to close position.	Install the new parts which have been damaged. Provide split pins & APDs in a proper manner.	Care should be taken to ensure that split pins and APDs are properly provided.
9.	<b>Missing of split pins – Bogie Components damaged</b>		
	Isolate the bogie by operating the isolating cock to close position.	Install the new parts which have been damaged. Provide split pins & APDs in a proper manner.	Care should be taken to ensure that split pins and APDs are properly provided.
10.	<b>Missing of APDs – Split pin used on Brake Cylinder Pin</b>		
	<b>Action by Depot / Workshop</b>		<b>Preventive Action</b>
	Provide the bush and dowel on the pin.		Care should be taken to ensure that the bush and the dowel should be used on brake cylinder mounting pins.
11.	<b>Missing of APDs – On the pin of Primary Brake Beam</b>		
	APDs to be provided over the mounting pins.		Care should be taken to ensure that the mounting pins are provided with APDs.

12.	<b>Missing of APDs – On the pin of Secondary Brake Beam</b>		
	<b>Action by Depot / Workshop</b>		<b>Preventive Action</b>
	APDs to be provided over the mounting pins.		Care should be taken to ensure that the mounting pins are provided with APDs.
13.	<b>Missing of APDs – On the pin of Push Rod</b>		
	<b>Action by Depot / Workshop</b>		<b>Preventive Action</b>
	APDs to be provided over the mounting pins.		Care should be taken to ensure that the mounting pins are provided with APDs.
14.	<b>Inappropriate APDs on APM Device</b>		
	Proper APD to be provided over the APM Device.		Care should be taken to ensure that the APD provided on the APM Device is appropriate so that it perform its intended function.
15.	<b>Hand brake - Incorrect location of Brackets</b>		
	Brackets to be moved to its correct location as per RDSO drawing.		Care should be taken to ensure that the brackets locations are correct as per the drawing. This can be checked by applying the brakes for proper functioning.
16.	<b>Missing of APDs – On the pin of Primary Brake Beam</b>		
	APDs to be provided over the mounting pins.		Care should be taken to ensure that the mounting pins are provided with APDs.
17.	<b>Missing of APDs – On the pin of Secondary Brake Beam</b>		
	Do the necessary correction and check whether the brakes are functional.		Care should be taken during the fitment of hand brake arrangement. Check the working of the hand brake arrangement by applying the brakes.
18.	<b>Missing of APDs – On the pin of Secondary Brake Beam</b>		
	<b>Action by en-route operating Staff</b>	<b>Action by Depot / Workshop</b>	<b>Preventive Action</b>
	Tie the hanging part to the under frame to prevent it from touching the moving parts of wagon.	Install new component. Provide the APDs to prevent re-occurrence.	APDs should be provided to prevent the moving out of components during service.
19.	<b>Wrong use of Isolating cock in BC Line</b>		
	In case, wherein wrong isolating cock has been used, if required isolate the wagon through DV instead of bogie.	Replace the isolating cock to with-vent type and check its working.	Care should be taken to use isolating cocks with vent in the BC line. During the testing, check the vent position of isolating cock by moving the handle to closed position during application and ensuring that the BC pressure gets exhausted.

### 306-F ISSUE OF BRAKE POWER CERTIFICATE –

All freight trains after being subjected to thorough freight examination will be given a Brake Power Certificate (BPC).

The standard formats for Brake Power Certificate are enclosed at **para 315**.

The brake power certificates of End to End **air brake stock** will be **White**. The colour of BPC for **Premium and CC Rakes** shall be **Green and Yellow** respectively.

The **minimum originating brake power** for air braked goods trains, running on **end-to-end** pattern of examination, shall be **90%** except wherever local instructions have specified higher level of brake power to meet specific requirement. Exception shall

only be made after prior approval of Chief Rolling Stock Engineer has been obtained for each individual case.( Reference RB's letter No.94/M(N)/951/57 dated 29.9.95)

The **originating brake power** for air braked goods trains, running **in close circuits shall be 100 %** with adequate brake block thickness. The originating brake power for air braked Premium rakes shall be **95%**.

Brake pipe pressure required in the air braked train with locomotive should be as follows:

<u>No. of wagons</u>	<u>On Locomotive</u>	<u>Min. on last wagon</u>
Up to 56	5.0 & 6.0 Kg/Cm <sup>2</sup> .	4.8 & 5.8Kg/Cm <sup>2</sup>
Beyond 56	5.0& 6.0 Kg/Cm <sup>2</sup>	4.7&5.7 Kg/Cm <sup>2</sup>

**xiii) The following procedure should be followed to issue the BPC after attachment of the locomotive:**

- All BP and FP hoses/ hose pipes on the train should be coupled up. The angle cocks in case of air brake stock at both ends of the wagon in brake pipe should be open. The angle cock at the end of brake van must be in closed position.
- Attach front wagon BP hose to BP hose & FP hose to FP hose of the locomotive.
- Ensure firmness and tightness of hoses with palm ends coupling and clips.
- Ensure that all the cut off angle cocks on brake pipes are in open position.
- Attend to all leaks by replacing MU washer, leaky hoses and angle cock assembly, if requisite BP & FP pressure is not coming in the last vehicle.
- Inoperative or defective brake cylinders should be isolated by putting the isolating cock handle in closed position.

### **307. PROCEDURE FOR EXAMINATION & SAFETY CERTIFICATION OF DEPARTMENTAL ROLLING STOCK:**

Examination and certification of the safety of wheels, under gear and structure of Brake Down crane is the responsibility of the Mechanical supervisor (SSE/Loco/Diesel/ C&W), who is the custodian of the crane. The safety certification shall be carried out at a periodicity of 30 days. Similarly, self propelled ART/ARMES are also to be examined and certified for the safety of structure and under gear at a periodicity of 30 days by the nominated Mechanical Supervisor (Loco/Diesel/ C&W Supervisor).

- i. All the departmental wagon stock which may run with goods trains, like camping, mobile training cars, OHE wiring trains etc. shall be allotted a C&W depot for Primary maintenance nominated by Chief Mechanical Engineer (or by nominated Mechanical Officer). The allotted depot shall be painted on the stock end wall. Wheels, under gear and structure of the stock shall be examined for safety and certified by the Mechanical Supervisor at the nominated C&W depot. This certificate shall be valid for a maximum period of 30 days from the date of issue.
- ii. Rolling stock, which cannot be dispatched to the nominated depot for primary maintenance shall be offered to the C&W Supervisor at the nearest Train Examination point for inspection and certification of wheels, under gear and structural safety. This certification shall be valid for 30 days from the date of issue



- iii. All departmental wagons in material trains/ballast trains/PQRS trains etc. shall be examined in terms of IRCA Pt.III 3.2.1. A detailed joint circular shall be issued by a Committee consisting of CME, CE & COM of the zonal railway or their nominated officers, which inter alia should include detailed guidelines for examination by C&W Supervisor for running of departmental trains/PQRS rake.
- iv. Tower wagons shall be inspected for safety in terms of Para 20317(2) of AC Traction manual by the Mechanical Supervisor (C&W Supervisor) of the nominated C&W depot nearest to the TRD depot where the Tower wagon is based. The base depot of the Tower wagon shall be painted on its end wall. For this purpose, C&W depot shall be nominated by Sr.DME/DME of the division in consultation with concerned Sr.DEE/TRDs. The certification shall be valid for a maximum period of 30 days/6000 kms, whichever is earlier. Thereafter, the Tower wagon shall be offered to the nominated C & W Supervisor for examination and safety certification again. In case, the Tower wagon is operating in a division away from the nominated depot, the same shall be offered to the nearest Train examining point for C&W examination as soon as the validity of the certificate expires.
- v. Track machines shall also be subjected to wheel, under gear and structural safety examination and certification by the Mechanical Supervisor at periodic intervals as decided by concerned Zonal Railways.
- vi. Notwithstanding the above periodic inspection by the nominated C & W Supervisor/Mechanical Supervisor, the Supervisor in charge/custodian of the rolling stock in question shall carryout inspection of the rolling stock before starting the operation. In case he notices/suspects any abnormality in the rolling stock regarding structural and under gear safety, he shall immediately arrange to offer the rolling stock for C & W examination afresh.

The Station Master shall not give permission to start the departmental train/any departmental rolling stock unless the supervisor in charge produces the valid safety certificate issued by the nominated Mechanical Supervisor in terms of GR 4.31 and GR 4.35.

( Rly.Bd's Letter No.2004/M(Safety)/Deptl. Stock dtd. 20.05.2004.)

### **308. IMPORTANT PARAMETERS TO BE ENSURED DURING FREIGHT TRAIN EXAMINATION:**

#### **308 A. BRAKE GEAR LIMIT AND CLEARANCES:**

<b>Description</b>	<b>Limit</b>
Brake block condemning limits	10 mm
Yard leaving thickness of brake block except BOY wagon	20 mm
'A' dimension of air brake stock fitted with CASNUB bogie except BOBRN wagon	70 mm +2 - 0
'A' dimension of BOBRN wagon	27 mm +2 - 0

#### **308B. PISTON STROKE:**

<b>Type of wagon</b>	<b>Piston Stroke</b>	
	<b>Empty</b>	<b>Loaded</b>
BOXN, BCN/BCNA, BRN, BTPGLN	85 mm +/- 10	130 mm +/- 10
BOXNHL, BCNHL	85 mm +/- 10	120 mm +/- 10

Type of wagon	Piston Stroke	
	Empty	Loaded
BTPN	85 mm +/- 10	130 mm +/- 10
BOY	90 mm +/- 10	135 mm +/- 10
BVZC	70 mm +/- 10	--
BOBRN	100 mm +/- 10	110 mm +/- 10
BOBYN	100 mm +/- 10	110 mm +/- 10
BLC	95 mm +/- 10	120 mm +/- 10
BVZI	32 mm	
BOSTHS, BTPN, BOBSN	85 mm +/- 10	130 mm +/- 10
ALL TYPES OF WAGON BMBS (KNORR BREMSE DESIGN)	54 ± 10 mm	--

**308C. BUFFER HEIGHT :**

Description	Limit
Buffer height from Rail level	Max. 1105 mm (Empty)
	Min. 1030 mm (Loaded)

**309. IMPORTANT PARAMETERS TO BE ENSURED DURING SICK LINE/ DEPOT ATTENTION****309 A. NOMINAL CLEARANCES OF CASNUB BOGIES**

Description	22W 22W(RETRO)	22W(M)	22NL NLB, NLM, NLC	22HS HS(MOD1), HS(MOD2), IRF108HS
Lateral clearance between side frame and bolster	18 mm	18 mm	18 mm	25 mm
Lateral clearance between side frame and axle box/adopter	25 mm	25 mm	16 mm	16 mm
Longitudinal clearance between side frames and axle box/adopter	2 mm	10 mm	9 mm	9 mm
Longitudinal clearance between side frame and bolster	6 mm	6 mm	6 mm	6 mm
Clearance between anti rotation lug and bolster	4 mm	4 mm	4 mm	4 mm

**309 B. WEAR LIMITS :**

Description	Limits
Adapter Thrust shoulder	0.7 mm
Adapter Crown lugs	4.0 mm
Adapter crown seat	3.5 mm
Adapter side lugs	3.0 mm
Adapter sides	3.0 mm
Side frame column friction plate	4.0 mm
Side frame column sides	5.0 mm
Side frame anti rotation lug	3.0 mm

Pedestal crown roof	5.0 mm
Pedestal crown sides	4.0 mm
Pedestal sides	2.0 mm
Pedestal jaw	4.0 mm
Bolster liner wear limit	5.0 mm
Bolster land surface	3.0 mm
Bolster column sides – Inner/Outer	5.0 mm

**309 C. LOAD/SNUBBER SPRINGS OF CASNUB**

Type of Bogie	Location	Free Height Nominal (mm)	Free condemning height (mm)
CASNUB 22W, W(Retro), W(M), NL, NLB, NLM & NLC	Outer	260	245
	Inner	262	247
	Snubber	294	279
CASNUB 22 HS	Outer	260	245
	Inner	243	228
	Snubber	293	278
CASNUB 22 HS (MOD-I)	Outer	253	238
	Inner	225	210
	Snubber	304	289
CASNUB 22 HS (MOD-II)	Outer	253	238
	Inner	222	207
	Snubber	304	289

**309 D. WEAR LIMIT FOR FRICTION WEDGE BLOCK**

Vertical Surface	7 mm
Slope Surface	3 mm

**309 E. CENTRE PIVOT WEAR LIMIT**

	CASNUB 22(W)	OTHERS
Vertical sides	5.5 mm	4.0 mm
Seat	4.0 mm	4.0 mm

**309 F. ELASTOMERIC PAD & CONSTANT CONTACT SIDE BEARER:**

Description	Nominal dimension	Dimension after permanent set (condemning size)
Elastomeric Pad	46 mm	42 mm
Constant contact side bearer pad		
a). Metal Bonded rubber pad	114 mm (pad only)	109 mm
b).PU CCSB for CASNUB 22HS	142.5 mm (With three rings)	137
c). PU CCSB for CASNUB 22NLB	134 mm (With two rings)	128.5

**309G. WHEEL & AXLE**

Description	Limits	
	New	Condemn.
Wheel dia used on BOXN/CASNUB bogie)	1000 mm	906 mm
Wheel dia used on BLC/ BLL	840 mm	780 mm

**310. INFRASTRUCTURE & FACILITIES REQUIRED IN THE YARD**

(Please refer to **Chapter 11** on Infrastructure Facilities)

**311. MACHINERY & PLANT ITEMS**

(Please refer to **Chapter 11** on Infrastructure Facilities)

**312. TOOLS REQUIRED**

(Please refer to **Chapter 11** on Infrastructure Facilities)

**313. MAN HOURS FOR VARIOUS TYPES OF EXAMINATIONS**

The man-hours for examination of various types of stock are given below **as a guideline**. CMEs of Zonal railways may however permit variation based on local conditions, typical characteristics prevailing at site and availability of infrastructural facilities.

**TABLE 3.2 Man-hours for Examination of various types of stock**

SN	Stock	Type of Examination		
		Terminating	Intensive	Originating
01	C.C. Examination	6 man hrs.	100 man hrs. per Rake	10 man hrs.
02	Intensive Examination (End-to-End running)	6 man hrs.	56 man hrs. per Rake	10 man hrs.

**Note:**

1. The distribution of intensive staff, gang wise with tools and material is given in Table 3.3.
2. The bench marking of staff for various wagon maintenance activities is under consideration and finalisation of Railway Board with Review committee. After finalisation, the para-313 shall be replaced with new bench mark recommendations of Railway Board.

[ Railway Board Letter No. 2008/M(N)/951/28 dated 05.01.2016 item No. 5 ]

**314. Examination of Container Trains (BLC/BLL Rakes)****(Ref: Railway Board's letter No. 2007/M(N)/951/67 dated 20.11.2008)****a. Additional points for examination of Container trains**

- The examination points for **Container trains** should be developed and provided with all necessary resources including infrastructural facilities, maintenance spares and staff, etc. for examination.
- The list of MANDATORY AND OPTIONAL FACILITIES is given in **Chapter 11**

**b. Special conditions for examination of container trains (Close Circuit)**

- The BLC rakes shall be based for maintenance at the nominated CC base depot. The examinations of BLC rakes shall be done in empty condition, i.e. without containers on the wagons.
- All CC rakes shall be given intensive examination at their base depot after which fresh BPC shall be issued these rakes, valid for 6000 Km or 30 days, whichever is earlier. In case kilometers are not logged on BPC, the validity of BPC shall be for 20 days only from date of its issue (including the date of issue). The rake shall be returned back to its base depot within validity of the BPC. The name of the base depot shall be clearly mentioned on the BPC. Route specific isolated cases, requiring more than 6000 Km validity, shall be dealt by Railway Board on case to case basis.
- Infrastructure facilities at all points nominated for CC examination of container trains shall be upgraded to "A" category (by ZRs in case the examination point is in the yard and by the concerned operator in case it is inside the ICD) on top priority.
- Till facilities are upgraded to "A" category, concerned DRMs (for points in Railway yards) and CTOs (for points inside ICDs) should ensure that proper lightening arrangements, material handling equipments, welding facilities are made available at these points immediately by hiring (if not possible otherwise) so that quality of examination/ repairs and safety is not compromised.
- All the rakes examined on CC pattern shall be subjected to safe to run examination by TXR (at TXR point) or by Guard & Loco pilot (at other points after every loading / unloading. Such safe to run examination, will be followed by endorsement or revalidation of original BPC. In such safe to run examination only brake power, hanging parts and other defects, which can be noticed visually on wagon loaded with containers, shall be checked and given proper attention.
- All CTOs shall monitor movement of their CC rakes and ensure that the rakes are worked back to their respective base depots before completion of stipulated kilometers/ days limit.
- All CTOs shall advise daily position of rake wise details of base, km and days since last examination to CRSE of the concerned ZR and Sr. DME of the concerned division through fax / email. Rake wise record shall be maintained on day to day basis by the divisional TXR control and also by the CC base depot. For this, CC base depots and TXR

control in the divisions shall be provided with computers, fax machine, telephone & broadband connection in GM/ DRM's powers.

- Rake with invalid BPC shall normally not be permitted to run in service. Further loading shall not be permitted in rakes with invalid BPC.
- In case the BPC of CC rake becomes invalid due to completion or near completion of 6000 km or 30 days (20 days if km are not logged on BPC) after issue of last BPC, at other than its base depot, it shall be handled in the following manner.

**c. In empty condition (containers off loaded from wagons):**

Rake shall be offered at the nearest TXR point for intensive examination, where after examination its BPC will be revalidated for a period of 7 days, with endorsement on BPC by TXR that rake is safe to run up to its base depot. During this period of 7 days, one loading/ unloading shall be permitted in the direction of CC base depot. The revalidation of BPC in above manner is permitted only once and rake shall be returned to its CC base depot within this 6 days period. Else, the rake shall lose its CC character and will become end to end rake. Re- conversion of such end to end rakes to CC shall be permitted only after personal approval of CME and COM of the concerned ZR.

**d. In loaded condition (container loaded on the wagons):**

Rake shall be offered at the nearest TXR point, for safe to run examination and endorsement on BPC by TXR that train is safe to run up to its destination. After unloading of consignment at destination, such potentially unsafe rake shall be offered at the nearest TXR point for safe to run examination and endorsement by TXR on BPC that the train is safe to run in unloaded condition up to its CC base depot. With containers loaded on wagon, shall be done only in case of extreme urgency with prior approval of COM & CME of concerned ZR.

- Container rakes detained for more than 24 hrs. at TXR point, shall be subjected to safe run examination and endorsement on BPC by TXR that the rake is safe to run for the remaining validity period of BPC.
- Besides special conditions mentioned herein above, with respect to examination and operation of container trains, all other instruction regarding maintenance of air braked freight stock and 6000 km CC rakes, issued from time to time, shall be observed.
- All necessary resources including infrastructural facilities, maintenance and unit exchange spares and staff etc. should be provided at above mentioned points, for ROH of container wagons. GM/ DRM should provide these resources under their extant powers within two months.

**e. Safety of Container wagon**

(Ref: Railway Board's letter No. 2006/M(N)/951/3 dated 02.03.2010)

- Locks of all the container wagons should be checked during intensive examination and 100% availability of operating lock should be ensured before giving BPC.
- Sufficient number of unit exchange spares should be made available to the maintenance units so that wagon are not detained for want of locks.

**f. Commissioning of new BLC / BLL Rakes**

All new rakes of BLC/ BLL wagons shall be commissioned by their respective CC base depot. The depot under taking commissioning of new BLC / BLL rakes will send detailed wagon-wise commissioning depot of such rakes to all concerned including Northern Railway, for centralize planning for ROH/ POH of all BLC/ BLL wagons. During movement of new rakes from the manufacturer's placed to CC based depot, rake can be loaded one time in the direction of CC base depot.

**g. Examination of Container Rakes in Loaded condition**

It is not feasible to examine BLC/ BLL wagons with containers loaded on wagons as under frame safety items can not be attended because of lower wheel diameter and floor height. In order to carry out examination of rakes in loaded conditions (container on wagon) on non pit lines, following inputs are required:

- Replacement of under frame mounted brake system with bogie mounted brake system for which a suitable design should be developed by RDSO.
- Mechanized defect detection systems like acoustic bearing detectors and online bogie monitoring systems etc. to be installed within 50 kilometers from base so that list of defects become available to TXR.

CTO may provide input as above or construct examination pit in their ICD or examination of rakes.

**315. Standardisation of Brake Power Certificates for various Train examinations.**

The Brake Power Certificate of End to End air brake stock will be White. The colour of BPC for Premium rake shall be Green and for CC Rakes, it shall be Yellow.

Minimum originating brake power for air braked goods trains, running on end-to-end pattern, Premium rakes & Close Circuits Rakes, shall be as per para 306F .

**Format-I, Format-II & Format -III** have been given for End to end examination, Premium examination and Close Circuit rakes examination respectively.

<b>BPC No.</b>	<b>Depot</b>	<b>Date</b>	<b>No.</b>

This rake is fitted with single pipe / twin pipe air brake system (Please tick)

**(Format – I)**

**BRAKE POWER CERTIFICATE FOR AIR BRAKE (GOODS)  
(END TO END EXAMINED RAKE)**

ISSUED BY : (Nominated Intensive Exam. Point/Div./Rly)

CUG/P&T No. of Depot

Destination (Valid up to)

Date

Train No.

Loco No.

Load & Stock

Total No. of Bk. Cyls.

No. of Operating Cylinders

Brake Power %

Air Pressure on Departure

	BP Pressure in Kg/cm <sup>2</sup>	FP Pressure in Kg/cm <sup>2</sup> (in case of Twin pipe rakes)
<b>In Locomotive</b>	<input style="width: 100%; height: 20px;" type="text"/>	<input style="width: 100%; height: 20px;" type="text"/>
<b>In Brake Van</b>	<input style="width: 100%; height: 20px;" type="text"/>	<input style="width: 100%; height: 20px;" type="text"/>

Engine attached at

Information by YM

Air pressure ready at

**INSTRUCTIONS**

**A. GUARDS AND LOCO PILOTS:**

***Before starting the train, guard and loco pilots should ensure:***

- i) No loco pilot move the loaded train from the loading point unless the destination is clearly mentioned on the Brake Power Certificate.
- ii) Continuity of air pressure from first to last vehicle of the train.
- iii) Before starting, train, crew should ensure CBC push & pull to avoid train uncoupling.
- iv) If BPC is invalid, inform the Control Office and take necessary instructions from C&W Controller.
- v) The incoming Loco Pilot shall hand over the brake power Certificate to relieving Loco Pilot. If he is leaving the train without relief, it shall be deposited with the nominated authority who will give it to the out going Loco Pilot.
- vi) The out going Loco Pilot & Guard will satisfy themselves from the listed wagon Nos. that the brake power certificate pertains to their train.

**THIS CERTIFICATE IS VALID:**

1. Provided the destination is mentioned on the BPC of the loaded train.
2. Provided the composition of the rake is not changed by 4 or more wagons.
3. Provided the rake is not stabled for more than 24 hours in train examination yard.
4. In case of BOST/BRNA, round trip BPC valid for 2000KMs/12 Days shall be issued by TXR after certification of loading & securing of the consignment. (Bds letter No. 2013/M(N)/951/22/CC Rakes dated 23.03.2015)



**B. LIST OF WAGONS IN ORDER:**

SN	WAGON No.	SN	WAGON No.	SN	WAGON No.	SN	WAGON No.
1		16		31		46	
2		17		32		47	
3		18		33		48	
4		19		34		49	
5		20		35		50	
6		21		36		51	
7		22		37		52	
8		23		38		53	
9		24		39		54	
19		25		40		55	
11		26		41		56	
12		27		42		57	
13		28		43		58	
14		29		44		59	
15		30		45		60	

Loco Pilot's Name & Signature	Guard's Name & Signature	SSE/JE(C&W) Name & Signature

**C. DETAILS OF CONTINUITY AND CHECKS CARRIED OUT BY GUARD AND DRIVER (GDR CHECKS) after each loading/unloading.**

S. No.	Date	Station	Loco Pilot Name & Signature	Guard's Name & Signature	SM/Dy. SS Name & Sign	Any Problem with the wagons
01						
02						
03						
04						
05						
06						
07						

**D. PARTICULARS OF WAGONS DETACHED/ATTACHED ENROUTE**

[ To be filled by Guard & Loco Pilot )

Sr. No.	Date	Stn	Wagon Nos. Detached/Attached	Reasons
1.				
2.				
3.				
4.				
5.				

**E. ENROUTE PROBLEMS NOTICED & ATTENTION GIVEN**

Date	Loco No.	Loco Pilot's/Guard Name	Loco Pilot/Guard's HQ	PROBLEMS & ACTION TAKEN		Sign of LP / Guard/STN. Staff
				STN	NATURE	

<b>BPC No.</b>	<b>Depot</b>	<b>Date</b>	<b>PM No.</b>

This rake is fitted with Single pipe / Twin pipe air brake system (Please tick)

**(Format – II)**

**BRAKE POWER CERTIFICATE FOR PREMIUM RAKE**

**This BPC is valid for 12 days, i.e. upto-----(mention date).**  
**After this date NO FRESH LOADING IS PERMITTED**  
**(3 days grace period after this date is allowed for rakes loaded upto above date)**

**ISSUED BY : (Exam. Point/Divn./Railway)**

**CUG/P&T No. of Base Depot:**

Date

Train No.

Loco No.

Load & Stock

Total No. of Bk. Cyls.

No. of Operating Cylinders

Brake Power %

Air Pressure on Departure

	BP Pressure in Kg/cm <sup>2</sup>	FP Pressure in Kg/cm <sup>2</sup> (in case of Twin pipe rakes)
<b>In Locomotive</b>		
<b>In Brake Van</b>		

Engine attached at  Information by YM  Air pressure ready at

**INSTRUCTIONS**

**A. GUARDS AND LOCO PILOTS:**

***Before starting the train, guard and loco pilots should ensure:***

- i) No loco pilot to move the loaded train from the loading point unless the destination is clearly mentioned on the Brake Power Certificate.
- ii) After each loading unloading point, before starting Loco pilot, Guard and station staff shall ensure that BPC is valid. The train should be subjected to GDR check as per Check list.
- iii) Continuity of air pressure from first to last vehicle of the train.
- iv) Before starting, train, crew should ensure CBC push & pull to avoid train uncoupling.
- v) If BPC is invalid, inform the Control Office and take necessary instructions from Traffic & C&W Controller.
- vi) The incoming Loco Pilot shall hand over the brake power Certificate to relieving Loco Pilot. If he is leaving the train without relief, it shall be deposited with the nominated authority who will give it to the out going Loco Pilot.
- vii) The out going Loco Pilot & Guard will satisfy themselves from the listed wagon Nos. that the brake power certificate pertains to their train.

**THIS CERTIFICATE IS VALID:**

1. Provided the composition of the rake is not changed by 4 or more wagons.
2. Provided the rake is not stabled for more than 24 hours in train examination yard.
3. 3days grace period is not for loading of train.

**B. LIST OF WAGONS IN ORDER:**

SN	WAGON No.	SN	WAGON No.	SN	WAGON No.	SN	WAGON No.
1		16		31		46	
2		17		32		47	
3		18		33		48	
4		19		34		49	
5		20		35		50	
6		21		36		51	
7		22		37		52	
8		23		38		53	
9		24		39		54	
19		25		40		55	
11		26		41		56	
12		27		42		57	
13		28		43		58	
14		29		44		59	
15		30		45		60	

Loco Pilot's Name & Signature	Guard's Name & Signature	SSE/JE (C&W) Name & Signature

**C. DETAILS OF CONTINUITY AND CHECKS CARRIED OUT BY GUARD AND DRIVER (GDR CHECKS) after each loading/unloading.**

S. No.	Date	Station	Loco Pilot Name & Signature	Guard's Name & Signature	SM/Dy. SS Name & Sign	Any Problem with the wagons
01						
02						
03						
04						
05						
06						
07						

**D. PARTICULARS OF WAGONS DETACHED/ATTACHED ENROUTE**

[ To be filled by Guard &amp; Loco Pilot )

Sr. No.	Date	Stn.	Wagon Nos. Detached/Attached	Reasons
1.				
2.				
3.				
4.				
5.				

**E. LOADING/UNLOADING DETAILS [ To be filled by Guard ]**

LOADING	Station.	Date of Loading	UNLOADING	Station.	Date of Unloading
1 <sup>st</sup> Loading			Destination		
2 <sup>nd</sup> Loading			Destination		
3 <sup>rd</sup> Loading			Destination		

**F. ENROUTE PROBLEMS NOTICED & ATTENTION GIVEN**

Date	Loco No.	Loco Pilot's/Guard Name	Loco Pilot/Guard's HQ	PROBLEMS & ACTION TAKEN		Sign of LP / Guard/STN. Staff
				STN	NATURE	

**(Format – III)**

**BRAKE POWER CERTIFICATE FOR AIR BRAKE (GOODS)  
CLOSE CIRCUIT EXAMINED RAKE [CC Rakes]**

**ISSUED BY : (Exam. Point/Divn./Railway)**

**CUG/P&T No. of Base Depot:**

**Nominated Close Circuits**

**BPC No.**  **DATE**

CC Rake ID No	Base Depot	Date	Month	Year	Hrs.	Min.	Sec

*This BPC is valid for 30 days, i.e. upto-----(mention date) or 6000 / 7500 Kms, whichever is earlier.  
A further grace period of 5 days is allowed if the rake is moving towards the base Depot  
**NO FRESH LOADING IS PERMITTED AFTER ----- (mention date) or completion of 6000 / 7500 Kms, whichever is earlier.***

**This rake is fitted with Single Pipe / Twin Pipe air brake system (Please tick)**

**This BPC is valid for the Close Circuit :..... (Mention the circuit)**

**INSTRUCTIONS**

**A. GUARDS AND LOCO PILOTS:**

1. Before starting the train, guard and driver should ensure:
  - i) Continuity of air pressure from first to last vehicle of the train.
  - ii) Validity of BPC, If found invalid, inform the control office immediately and take necessary instructions from Traffic controller in consultation with C&W Control/Sr.DME/C&W.
  - iii) Before starting, train crew should ensure CBC push & pull to avoid train uncoupling.
2. Loco Pilot and guard should correctly log the kilometres earned on the BPC. If no, the BPC will be deemed to be **valid for 20 Days only** from the date of issue.
3. The incoming Loco Pilot shall hand over the brake power Certificate to relieving Loco Pilot. If he is leaving the train without relief, it shall be deposited with the nominated authority who will give it to the out going Loco Pilot.
4. The out-going Loco Pilot & Guard will satisfy themselves from the listed wagon Nos. that the brake power certificate pertains to their train.

**B. STATION STAFF:**

They should be vigilant for averting any theft or tampering with this rake. Any incident of theft tampering to be reported to C&W Control and entry made by Guard in the space provided.

**THIS CERTIFICATE IS VALID –**

- I. Provided the rake integrity as listed in the BPC is maintained and replacement of not more than 04 wagons has taken place during the entire run.
- II. Provided the rake is not stabled for more than 24 hours in train examination yard.
- III. Provided the rake is running in pre-defined close circuit as mentioned above.

**C. TO BE FILLED AT THE ORGINATING EXAMINATION POINT BY TRAIN EXAMINING STAFF:**

1. Train No.  2. Loco No.

3. Load & stock  4. Total No. Bk. Cyls.

5. No. of Operating Cyls.  6. Brake Power %

7. Air Pressure on Departure:

	<b>BPP</b> Kg/cm <sup>2</sup>	in	<b>FPP in Kg/cm<sup>2</sup></b> (in case of Twin pipe rakes)
<b>In Locomotive</b>			
<b>In Brake Van</b>			

8. Engine attached at time  9. Information by YM at time

10. Air pressure ready at time  11. Line No.

**LIST OF WAGONS IN ORDER**

S. No.	WAGON No.	S. No.	WAGON No.	S. No.	WAGON No.
1		21		41	
2		22		42	
3		23		43	
4		24		44	
5		25		45	
6		26		46	
7		27		47	
8		28		48	
9		29		49	
19		30		50	
11		31		51	
12		32		52	
13		33		53	
14		34		54	
15		35		55	
16		36		56	
17		37		57	
18		38		58	
19		39		59	
20		40		60	

<b>Loco Pilot's Name &amp; Sign</b>	<b>Guard's Name &amp; Sign</b>	<b>SSE/JE(C&amp;W) Name &amp; Sign.</b>







TABLE 3.3

**CATEGORISATION OF FREIGHT TRAIN EXAMINATION POINTS INCLUDING YARDS, SICK LINES AND ROH DEPOTS  
(As on 11-07-2017)**

S.	Railway	Division	NAME OF POINTS	Station Code	Prem. Points	CC Points	Exam. Yards	Sick Lines	ROH Depots
1	CR	BB	VADALA ROAD	VDLR			D	B	
		BB	KALYAN	KYN	Pr.		C	A	
		BB	TROMBEY	TMBY			D	B	
		BSL	BHUSAVAL	BSL	Pr.	CC	A	E	A
		NGP	AJNI	AQ (ICD)	Pr.	CC	A	A	C
		PA	MIRAJ	MRJ			C	E	
		SUR	WADI	WADI	Pr.	CC	A	B	
		SUR	DAUND	DD	Pr.		A	A	A
					<b>TOTAL</b>	<b>5</b>	<b>3</b>	<b>8</b>	<b>8</b>
2	ER	ASN	ANDAL-UP YARD	UDL-Up	Pr.	CC	B	A	A
		ASN	DURGAPUR STEEL EXCHANGE	DSEY	Pr.		C	E	
		ASN	ANDAL EMP- YARD	UDL (Emp-Yd)	Pr.		C		
		ASN	SITA RAMPUR	STN			F	F	
		ASN	ANDAL DN YARD	UDL (Dn Yd)	Pr.		C	B	
		HWH	PAKUR	PKR	Pr.	CC	C	A	
		MLDT	JAMALPUR	JMP			F	F	
		MLDT	MALDA TOWN	MLDT	Pr.		A	A	
		SDAH	NAIHATI	NH	Pr.	CC	A	A	A
		SDAH	BUGBUG	BGB			F	F	
		SDAH	CHITPUR	CP	Pr.	CC	A	A	
		SDAH	MAJERHAT	MJT (ICD)/(KoPT)		CC	A	F	
			<b>TOTAL</b>	<b>8</b>	<b>5</b>	<b>12</b>	<b>11</b>	<b>2</b>	
3	ECR	DHN	BARVADIH	BRWD		CC	A	A	A
		DHN	PATHER DIH	PEH	Pr.	CC	D	C	
		DHN	OBRA	OBR	Pr.	CC	C	B	
		DHN	PATRATU	PTRU	Pr.		E	F	

		<b>MGS</b>	MUGALSARAI	MGS (DRY)	<b>Pr</b>	<b>CC</b>	<b>A</b>	<b>B</b>	<b>A</b>
		<b>MGS</b>	MUGALSARAI	MGS (DDY)			<b>F</b>		
		<b>MGS</b>	MUGALSARAI	MGS (UDY)	<b>Pr.</b>		<b>D</b>		
		<b>SEE</b>	NARAYANPUR ANANT	NRPA	<b>Pr.</b>		<b>C</b>	<b>B</b>	
		<b>SEE</b>	GHARHRA	GHZ	<b>Pr.</b>		<b>E</b>	<b>F</b>	
				<b>TOTAL</b>	<b>7</b>	<b>4</b>	<b>9</b>	<b>7</b>	<b>2</b>
<b>4</b>	<b>ECoR</b>	<b>KUR</b>	CUTTC	CTC	<b>Pr.</b>		<b>D</b>	<b>B</b>	
		<b>KUR</b>	PARADEEP	PRDP			<b>D</b>	<b>F</b>	<b>A</b>
		<b>SAMBALPUR</b>	KATABHANJI	KBJ			<b>D</b>	<b>F</b>	
		<b>WAT</b>	VISAKHAPATNAM-ORE EXCHANGE	VSKP-OEC	<b>Pr.</b>	<b>CC</b>	<b>A</b>	<b>A</b>	<b>A</b>
		<b>WAT</b>	VISAKHAPATNAM-RAW MAT YARD	VSPS-RMUY	<b>Pr.</b>	<b>CC</b>	<b>A</b>	<b>A</b>	<b>A</b>
		<b>WAT</b>	VISAKHAPATNAM-RECEPTION YARD	VSKP-R Yd	<b>Pr.</b>	<b>CC</b>	<b>A</b>		
		<b>WAT</b>	VISAKHAPATNAM	VSKP-CSL				<b>A</b>	<b>A</b>
		<b>WAT</b>	VISAKHAPATNAM	VSPS-FPY	<b>Pr.</b>		<b>B</b>		
		<b>WAT</b>	RAIGADA	RGDA			<b>F</b>		
				<b>TOTAL</b>	<b>5</b>	<b>3</b>	<b>8</b>	<b>6</b>	<b>4</b>
<b>5</b>	<b>NR</b>	<b>DLI</b>	TUGLKABAD	TKD	<b>Pr.</b>	<b>CC</b>	<b>A</b>	<b>A</b>	<b>A</b>
		<b>DLI</b>	GHAZIABAD	GZB	<b>Pr.</b>		<b>B</b>	<b>A</b>	
		<b>DLI</b>	SAKURBASTI	SSB			<b>B</b>	<b>B</b>	
		<b>FZR</b>	LUDHIANA	LDH	<b>Pr.</b>	<b>CC</b>	<b>A</b>	<b>A</b>	
		<b>FZR</b>	AMRITSAR	ASR			<b>D</b>	<b>A</b>	
		<b>FZR</b>	JULANDHAR	JUC	<b>Pr.</b>		<b>C</b>	<b>F</b>	
		<b>FZR</b>	JAMMU TAVI	JAT			<b>F</b>	<b>A</b>	
		<b>LKO</b>	LUCKNOW	LKO			<b>B</b>	<b>A</b>	
		<b>MB</b>	MORADABAD	MB					<b>A</b>
		<b>UMB</b>	AMBALA	UMB	<b>Pr.</b>	<b>CC</b>	<b>A</b>	<b>A</b>	<b>A</b>
		<b>UMB</b>	KHANAALAMPURA	KJGY	<b>Pr.</b>	<b>CC</b>	<b>A</b>	<b>A</b>	<b>A</b>
		<b>UMB</b>	BHATINDA	BTI	<b>Pr.</b>		<b>A</b>	<b>A</b>	
				PTK			<b>F</b>		
		<b>UMB</b>		RTP			<b>F</b>		
				<b>TOTAL</b>	<b>7</b>	<b>4</b>	<b>13</b>	<b>11</b>	<b>4</b>
<b>6</b>	<b>NCR</b>	<b>AGC</b>	BAD	BAD	<b>Pr.</b>		<b>A</b>	<b>A</b>	<b>C</b>
		<b>ALD</b>	KANPUR	GMC (ICD)/CPC	<b>Pr.</b>	<b>CC</b>	<b>C</b>	<b>A</b>	<b>A</b>
		<b>ALD</b>	KLPL(ICD)/Panki	Panki			<b>A</b>		

		<b>ALD</b>	DADRI	DER (ICD)		<b>CC</b>	<b>A</b>		
		<b>ALD</b>	ARIL(ICD)/Khurja	KRJ			<b>A</b>		
		<b>JHS</b>	JHANSI	JHS	<b>Pr.</b>		<b>A</b>	<b>F</b>	<b>C</b>
				<b>TOTAL</b>	<b>3</b>	<b>2</b>	<b>6</b>	<b>3</b>	<b>3</b>
<b>7</b>	<b>NER</b>	<b>LJN</b>	GONDA	GONDA	<b>Pr.</b>		<b>A</b>	<b>F</b>	
				<b>TOTAL</b>	<b>1</b>	<b>0</b>	<b>1</b>	<b>1</b>	<b>0</b>
<b>8</b>	<b>NFR</b>	<b>KIR</b>	NEW JALPAIGUDI	NJP	<b>Pr.</b>	<b>CC</b>	<b>A</b>	<b>A</b>	<b>A</b>
		<b>LMG</b>	NEW GUHATI	NGC	<b>Pr.</b>		<b>A</b>	<b>A</b>	<b>A</b>
		<b>RNY</b>	NEW BOGAIGAON	NBQ	<b>Pr.</b>		<b>A</b>	<b>A</b>	
		<b>TSK</b>	NEW TINSUKHIA	NTSK	<b>Pr.</b>		<b>A</b>	<b>A</b>	<b>B</b>
				<b>TOTAL</b>	<b>4</b>	<b>1</b>	<b>4</b>	<b>4</b>	<b>3</b>
<b>9</b>	<b>NWR</b>	<b>AII</b>	MADAR	MD	<b>Pr.</b>	<b>CC</b>	<b>A</b>	<b>A</b>	<b>B</b>
		<b>JP</b>	PALI (ICD KRIBHCO)	PALI		<b>CC</b>	<b>D</b>		
				<b>TOTAL</b>	<b>1</b>	<b>2</b>	<b>2</b>	<b>1</b>	<b>1</b>
<b>10</b>	<b>SR</b>	<b>MAS</b>	JOLARPET	JTJ	<b>Pr.</b>	<b>CC</b>	<b>A</b>	<b>A</b>	<b>A</b>
		<b>MAS</b>	TONDIYARPET	TNPM (ICD)	<b>Pr.</b>	<b>CC</b>	<b>A</b>	<b>A</b>	<b>B</b>
		<b>MAS</b>	MADRAS HARBAR	HOM			<b>F</b>	<b>F</b>	
		<b>MAS</b>	ARRAKORAM/MELPAKKAM	AJJ/MLPM		<b>CC(BLC)</b>	<b>D</b>		
		<b>MAS</b>	PATTAVIRAM SIDING	PTMS			<b>F</b>		
		<b>MDU</b>	MEILAVATTAN	MVN	<b>Pr.</b>		<b>B</b>	<b>A</b>	
		<b>SA</b>	ERODE	ED	<b>Pr.</b>		<b>D</b>	<b>A</b>	
		<b>TPG</b>	TRICHCHIRAPALLI GOODS YARD	TPGY	<b>Pr.</b>		<b>A</b>	<b>F</b>	
		<b>TPG</b>	UDAGAMANDALAM	UMG		<b>CC(BOBRN)</b>	<b>F</b>		
		<b>TVC</b>	EARNAKULAM MARSHLING YARD	ERMG	<b>Pr.</b>	<b>CC</b>	<b>B</b>	<b>A</b>	
		<b>TVC</b>	IRUMPANAM	IPN	<b>Pr.</b>	<b>CC (BTPN)</b>	<b>B</b>	<b>A</b>	
				<b>TOTAL</b>	<b>7</b>	<b>6</b>	<b>11</b>	<b>8</b>	<b>2</b>

11	SCR	BZA	VIZAYVADA	BZA	Pr.	CC	A	A	A
		BZA	KAKINADA PORT	COA	Pr.		E	A	
		GTL	GOOTY	GY	Pr.	CC	D	A	A
		HYB	NIZAMABAD	NZB					
		NANDED	PURNA	PAU	Pr.		D	F	
		SC	SANATNAGAR	SNF (ICD) (SNAG)	Pr.	CC	A	E	
		SC	KAZIPET	KZJ			E	B	
		SC	RAMAGUNDAM	RDM	Pr.	CC	D	E	A
		SC	BELLAMPALLI	BPA	Pr.	CC	D	E	
				TOTAL	7	5	8	8	3
12	SER	ADA	BOKARO STEEL CITY EMP YARD	BKSC (EmpYd)	Pr.	CC			A
		ADA	BOKARO STEEL CITY OUT YARD	BKSC (OutYd)	Pr.		B	F	
		CKP	BANDAMUNDA EX YARD	BNDM Ex Yd	Pr.	CC	A		
		CKP	BANDAMUNDA DEP- YARD	BNDM Dep Yd	Pr.		C		
		CKP	BANDAMUNDA MED SICK LINE	BNDM MSL				A	
		CKP	BANDAMUNDA CENTRAL SICK LINE	BNDM CSL				A	A
		CKP	DONGAPOSU	DPS	Pr.	CC	D	F	
		CKP	TATA	TATA	Pr.	CC	D	A	A
		CKP	ADITYPUR	ADTP	Pr.	CC	B	A	A
		KGP	NIMPURA	NMP	Pr.	CC	B	A	A
		KGP	BHOJUDIH	BJE	Pr.		D	A	
		KGP	HALDIA	HLZ	Pr.		F	F	

				TOTAL	10	6	9	9	5
13	SECR	BSP	BILASPUR	BSP	Pr.	CC	A	F	A
		BSP	LIPTON SIDING/AKALTARA	LIL-AKT			C		
		BSP	KORBA	KRBA	Pr.		C	F	
		NGP	DONGAR GARH	DGG	Pr.		A	F	
		R	BHILAI MARSHLING YARD	BMV (Rep Yd)	Pr.	CC	B	A	
		R	BHILAI EXCHANGE YARD	BIA (ExYd)	Pr.		B	B	
		RAIPUR	BHILAI PP YARD	BIA (PP Yd)	Pr.	CC	A	A	A
		RAIPUR	DALLI RAJHRA	DRZ		CC	E	F	
				TOTAL	6	4	8	7	2
14	SWR	MYS	HARIHAR	HRR		CC	A	A	
		MYS	MYSORE NEW GOODS TERMINAL	MNGT			C	A	B
		SBC	SETELITE GOODS TERMINAL	SGT	Pr.	CC	A	A	
		SBC	WHILD FIELD	WFD (ICD)		CC	A		
		UBL	HOSEPET	HPT		CC	B	C	B
		UBL	JSWT(Pvt.Siding)				A		
		UBL	NAVALUR	NVU			B	A	
				TOTAL	1	4	7	5	2
15	WR	ADI	GANDHI DHAM	GIM	Pr.	CC	A	A	B
		ADI	SABARMATI	SBI (ICD)	Pr.	CC	A	A	A
		ADI	VATVA	VTA					A
		BRC	BARODA YARD	BRCY	Pr.	CC	A	A	B
		BRC	KARCHIA	KRCA	Pr.	CC	A	A	B
		RJT	HAPA	HXP	Pr.		A	A	B
		RTM	RATLAM	RTM					B

		RTM	SAMBHUPURA	SMP	Pr.	CC	A	A		
				<b>TOTAL</b>	<b>6</b>	<b>5</b>	<b>6</b>	<b>6</b>	<b>7</b>	
16	WCR	JBP	NEW KATNI	NKJ New	Pr.	CC	D	A		
		JBP	NEW KATNI-DEP YARD	NKJ Dep Yd	Pr.	CC	A		A	
		JBP	NEW KATNI-OLD YARD	NKJ Old					A	
		BPL	GASS AUTHORITY LTD Vijaipur	GAIL Siding				B		
		KTT	SAKTPURA siding of kota therma power	SKT				D		
		JBP	ETARSI	ET	Pr.			D	A	B
		KTT	KOTA	KTT	Pr.			D	A	C
		JBP	SATNA	STA	Pr.	CC	D	A	A	
					<b>TOTAL</b>	<b>5</b>	<b>3</b>	<b>7</b>	<b>5</b>	<b>4</b>
<b>IR - GRAND TOTAL</b>					<b>83</b>	<b>57</b>	<b>119</b>	<b>100</b>	<b>47</b>	





**TABLE 3.4****DISTRIBUTION OF INTENSIVE STAFF, GANG WISE WITH TOOLS AND MATERIAL TO CARRY**

<b>S. No.</b>	<b>Gang</b>	<b>Tools</b>	<b>Material to carry</b>	<b>Items to be examined/Repaired ( Air Brake )</b>
1	“A” having 2 Sk +2U/Sk	Hammer 2, Monkey spanner Chisel 1, Spanner 2 (3/8”X 7/16” & 2”X 1/2”)	MU washer /BP hose-2, MS bolts 2X1/2, Knuckle pin-4, Dummy plug-2 (spare)	CBC & its components, setting of CBC lock piece with toggle, knuckle pin, Brake pipe & BP air hose, MU washer, angle cock, Isolating cock.
2	“B” having 3Sk+ 3U/Sk	Hammer 3, Chisel 2 Round Punch 2, Spanner 2 (3/8”X 7/16”	Brake block, Brake gear pins, Brake gear cotter No.5,6&7. Split pins 2-1/2”X1/4”, 3-1/2”X5/16”, 4”X3/8” Brake shoe key, washers (Plain & spring) , other type of split pins	Brake blocks, brake shoe key, split pin, washer, cotter and brake shoe key safety fittings, APD, Brake beam safety bracket, safety loops, bolts, SAB safety bracket, Pull rod safety bracket, tyre defect gauge
3	“C” having 1Sk+ 2U/Sk	Hand Hammer 1, Chisel 1 Spanners 1/2”X 3/8”, 5/8”X 3/4” 3/8”X 7/16” 1/4”X 5/16”	Guard van valve with diaphragm.	Distributor valve, piston stroke, Brake power by testing the rake with air compressor and testing rig.
4.	“D” having 3Sk +3U/Sk	Hand Hammer 3, Chisel 3 Punch Round 3 Punch cotter 3 Ring spanner 2, Plain spanner2 1/2X5/8” and 3/4X7/8”	Buffer bolts 3-1/2X3/4”, spring washer,.	EM pad, bolster spring, snubber spring, adopter, side frame key, side bearer, Centre pivot top, Centre pivot pin.
5.	“E” having 1Sk +2U/Sk	Hand Hammer 2 Spanner 1/2X3/8 -1	-----	Axle boxes, Rolling in examination, work with “C” gang for Testing brake power and other Misc. work.

**TABLE 3.5**  
**WARRANTY PERIOD OF VARIOUS FREIGHT STOCK ITEMS**

<b>SNo.</b>	<b>Description</b>	<b>Warranty Period</b>	<b>Reference</b>
1.	New Wagons	24 Months from the date of commissioning.	Rly. Board's letter No. 2006/RS(!) /954/31/1566 dated 27.10. 06
2.	CTRB	48 Months from the date of supply or 36 Months from the date of commissioning.	RDSO's STR No. AB/RB-39 (Rev.-3) Amendment No. 2
3.	Adapters	48 Months from the date of supply or 36 Months from the date of commissioning.	RDSO's STR No. AB/RB-39 (Rev.-3) Amendment No. 2
4.	BP Hoses	36 Months from the date of supply or 24 Months from the date of commissioning.	RDSO's Specification No. 02-ABR-02
5.	Brake Cylinder	36 Months from the date of supply or 24 Months from the date of commissioning.	RDSO's Specification No. 02-ABR-02
6.	SAB	36 Months from the date of supply or 24 Months from the date of commissioning.	RDSO's Specification No. 02-ABR-02
7.	CC Pads	30 Months from the date of supply.	RDSO's STR No. WD-03-Misc-86 (Rev-3) ) Amendment No. 3
8.	PU Side Bearers	30 Months from the date of supply.	RDSO's Specification No. WD-38-Misc-2004 (Rev-1) )
9.	EM Pads	30 Months from the date of supply.	RDSO's Specification No. WD-20-Misc-95 (Rev-3) )
10	CBC Coupler, Yoke, Knuckle	54 Months from the date of supply or 42 Months from the date of commissioning.	RDSO's STR No. 48-BD-08
11.	Draft Gear	54 Months from the date of supply or 42 Months from the date of commissioning.	RDSO's STR No. 48-BD-08
12	Distributor Valve	36 Months from the date of supply or 24 Months from the date of commissioning.	RDSO's Specification No. 02-ABR-02
13	Angle Cock	36 Months from the date of supply or 24 Months from the date of commissioning.	RDSO's Specification No. 02-ABR-02
14.	Composite Brake Block	18 Months from the date of supply.	RDSO's Specification No. WD-13-ABR-2006



*( MAINTENANCE MANUAL FOR WAGONS- 2015 )*

# CHAPTER - 4



# WAGON BODY



## **CHAPTER 4**

### **WAGON BODY**

#### **401. INTRODUCTION**

The superstructure attached to the underframe of a wagon is called wagon body. It consists of body side and ends with their supporting structures such as stanchions, corner angle in case of open wagons, copings, roof structures, carlines; roof sheets in the case of covered wagons; hoppers and their supporting members in case of hopper wagons; tank barrels, cladding, if any, and supporting saddles in the case of tank wagons. Doors, door fittings, operating handles, louvers for ventilation and various fittings such as cleats, handles, hooks, footsteps, hand brake wheel and ladders also form part of the body.

This chapter is concerned with the body or superstructure of general purpose open and covered wagons, hopper wagons, bogie flat wagons including container wagons and military wagons. The Superstructure and fittings of tank wagons are dealt with separately in the Chapter 9 on Tank wagon.

#### **402. GENERAL CONSTRUCTION OF OPEN WAGON**

##### **A. SIDES**

Sides are made up of side panels and side stanchions, which are attached to the underframe by crib angles and side stanchions. They include top copings, intermediate copings if any, doors, door fittings, hand holds, tarpaulin cleats and label holders.

##### **B. ENDS**

Ends are similar in construction to sides in that they consist of end panels, end stanchions, top copings and intermediate copings. Attachment to the underframe is by means of end floor angles, corner angles and through the stanchions. Corner angles connect the ends with the sides. Open wagons have reinforcing angles at each end together with reinforcing gussets and corner pressings at the corner top.

##### **C. DOORS**

Each side of the wagon is provided with door for manual unloading. The doors are hinged at the bottom with locking arrangement by chainless cotter at the top. In BOXN wagons two locking bolts per door have been provided to avoid slipping of chainless cotter during tipping of wagon.

#### **403. GENERAL CONSTRUCTION OF COVERED WAGON**

##### **A. SIDES**

Sides are made up of side panels and side stanchions, which are attached to the underframe by crib angles. They include top copings, doors, door fittings, label

holders, rain protection angles above swing doors, door striking plates and anti bleeding device below the flap doors.

**B. ENDS**

Ends are similar in construction to sides in that they consist of end panels, end stanchions, top copings and in some cases, intermediate copings. Attachment to the underframe is by means of end floor angles, end angles and through the stanchions. Covered wagons are provided with ventilators at the upper end of body ends. Corner angles connect the ends with the sides.

**C. ROOF**

Roofs of covered wagons consist of roof sheets and carlines. Roof sheets are much thinner than the sheets used for the body sides and end panels.

**D. DOOR**

Each side of the wagon is provided with door for manual unloading. The doors consist of swing doors at the top with label holder hinged to the angles on the sides and flap doors at the bottom, hinged at the bottom with Anti bleeding device.

**404. GENERAL CONSTRUCTION OF FLAT WAGON AND WELL WAGON**

**A. ENDS**

Flat/well wagons do not have side wall and roof. The superstructure consists of either fixed or flexible ends. These are fixed to the underframe through stanchions, side attachment plates and crib angle.

**B. SIDE STANCHION**

Flexible side stanchions are attached to the sole bar through brackets. In addition, support brackets are also provided in rail wagons and well wagon. In container flat wagons, retractable anchoring locks are provided.

**405. GENERAL CONSTRUCTION OF HOPPER WAGON**

**A. SIDES**

Sides are made up of side panels and side stanchions, which are attached to the underframe. They include top copings, side stiffeners, doors in side discharge wagons, and label holders.

**B. ENDS**

Ends consist of end panels, end stanchions, end top copings and in some cases, stiffeners. Attachment to the underframe is through the stanchions. Corner angles connect the ends with the sides.

**C. DOOR AND DOOR OPERATING MECHANISM**

Hopper wagons are provided with either side discharge/centre discharge doors or both. Door operating mechanism is generally manually operated by means of bevel wheel and worm wheel connected to door operating hand wheel. In some

special type of hopper wagons like BOBRN, pneumatically operated door operating mechanism has been provided.

#### **406. NATURE OF REPAIRS REQUIRED IN WAGON BODY**

Apart from wagons involved in accidents or other serious mishaps, attention is normally necessitated because of the following defects:-

- i. Corrosion of panels, floor plates and roof sheets.
- ii. Puncturing of panels due to improper loading, inadequately secured consignments or deliberate tampering.
- iii. Bulging of ends due to shifting of loads.
- iv. Tearing of panels, fracture of stanchions and shearing of rivets due to severe impacts, and shifting of loads.
- v. Corrosion of end floor angles and crib angles.
- vi. Bulging of side usually occur after a prolonged period in service.
- vii. Slackening of rivets due to the combined effect of ageing, corrosion, wear and tear.
- viii. Weakening of welded joints due to loss of weld metal by corrosion, wear and tear.
- ix. Wearing out of door hinges.
- x. Damage to door fittings because of wear and tear or mishandling.
- xi. Distortion of doors mainly because of mishandling.
- xii. Failure of welded joints.
- xiii. Distortion or cracking of stanchions and other structural members because of abnormal loads, e.g., those due to defective clamping on tippers.
- xiv. Wear and tear or breakage of miscellaneous fittings, such as ladders, cleats, label holders etc.
- xv. Damages due to mechanised loading/ unloading (Payloaders/ Tippers)

#### **407. CORROSION IN WAGON BODY**

*The corrosion of wagon floor and roof sheets results from:*

- i. Water logging in crevices and overlaps. This is greatly accentuated if cleaning is neglected, since the accumulated dust and refuse retain moisture for a prolonged period.
- ii. Contact of panels with residues from corrosive consignments e.g., salt, fertilizers etc.
- iii. Spillage of corrosive fluids due to defective packing or rough handling.
- iv. Escape of corrosive vapours from the consignment.
- v. Inadequate protection from weathering because of poor painting or inadequate surface preparation.
- vi. The current practice is to paint only the exterior of the wagon body and not the interior, except for inside panels up to a height of 230 mm from floor, rivet seams in the case of covered wagons, the swing and flap doors and the roof. The interior is left largely unpainted because paints have hitherto not been available which could withstand the constant scrubbing action of the consignment against the wagon walls. It is nevertheless a fact that most of the time corrosion originates from the interior of a wagon rather than the exterior.

## **408. ANTICORROSIVE MEASURES**

- i. The most important anti corrosive measure to be taken in day to day working is to ensure that the wagon is kept thoroughly clean and receives special attention in this respect after it has transported a corrosive or hygroscopic commodity.
- ii. The second important step to prevent corrosion is to ensure that cleaning, surface preparation and painting are carried out with due thoroughness. The correct procedure to be followed in major maintenance schedules is given at the end of this chapter. The procedure to be adopted at the time of minor repairs should come as close to this as practicable.
- iii. While attending to miscellaneous repairs, panel patching or welding; it is important to ensure that surfaces in contact are well fitted to avoid water pockets. Due care is to be taken to clean and paint the affected surfaces to prevent corrosion by electrochemical action.
- iv. Use of Stainless Steel (IRS: M44) has been started in wagon rehabilitation/ new manufacture. This material has much better corrosion resistance.

## **409. REJECTABLE DEFECTS**

The inspection of wagon body is to be carried out in sicklines and workshops as per procedure laid down in IRCA Part-III Rule 4.2 & 4.7.

## **410. REPAIRS IN SICKLINE & ROH DEPOT**

### **410A PANEL PATCHING**

The bottoms of body side and end sheets are particularly vulnerable to destruction by corrosion and also puncturing by miscreants. If the area to be patched extends beyond 260 mm from the floor height, either two standard patches of 5 mm thickness should be used one above the other or a single special patch of 5 mm thickness and a width of 520 mm should be used. In case two or more adjacent panels require patching at a time, the complete length of corrosion can be covered by a special patch, which must, however, extend from stanchion to stanchion, as shown in figure 4.1. The standard panel patches for BOXN wagons are given in Table- 4.1. For detailed instructions of panel patching for BOXN wagon RDSO Drg. No. WD-94047-S-1 may be referred. In case of BCN/BCNA wagons, the thickness of plate should be 3.15 mm for end & sides and 1.6 mm for roof and the sizes depends on affected area to be covered for repair.



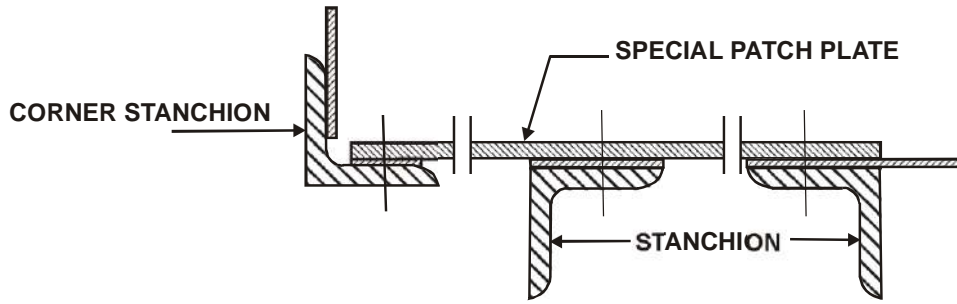


FIG 4.1

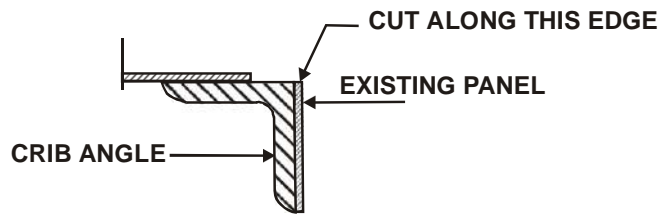


FIG 4.2

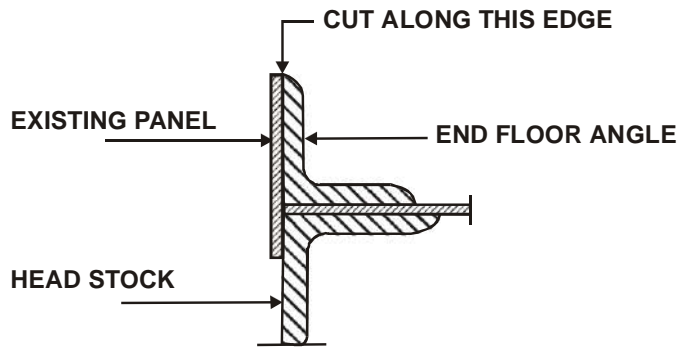


FIG 4.3

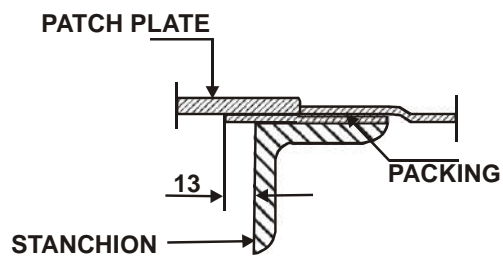


FIG 4.4

TABLE- 4.1

## PANEL PATCHES FOR BOXN WAGON

S. No	Width (mm)			Plate length (mm)	Plate thickness (mm)	Material specification
	Step size A	Step size B	Step size C			
1.	300	610	1275	552	5	IS:2062 E250
2.	300	610	-	552	5	"
3.	300	680	-	1470	5	"
4.	300	680	-	1445	5	"
5.	300	525	1170	1445	5	"
6.	315	-	-	1470	5	"
7.	300	600	850	445	5	"
8.	820	-	-	445	5	"
9.	300	600	850	555	5	"
10.	820	-	-	555	5	"
11.	300	600	850	700	5	"
12.	820	-	-	700	5	"

- i. For locations other than the skirting plates, damaged panels should be replaced by using standard patches. These patches should invariably be of the same thickness as the damaged panel.
- ii. Sick lines may weld or rivet smaller patches to take care of minor damages, but in no case, should a patch of less than 100 mm on any one side be used. If the patch is attached by riveting there should not be less than 8 rivets securing the patch. The pitch of the rivets must also not exceed 90 mm.
- iii. Standard patch plates should, preferably be kept ready in stock in shops and sicklines after proper surface cleaning and painting with two coats of zinc chromate primer.

**410B. PROCEDURE FOR WELDED PATCHES**

- i. Examine and mark the area of patch to be cut. Cut the corroded panel along crib/end floor angle and up to a height suitable for standard patches, as shown in Fig. 4.2 and 4.3. The 2.5 mm thick old panel sheet at the stanchion should be retained as a packing piece if not badly corroded. Otherwise use fresh 5 mm thick packing (RDSO Drawing No. WD-94047-S-1). The packing should extend 13mm wherever lap welding of the new patch with packing piece is involved (See Fig. 4.4).
- ii. Cut rivets on stanchion as required and end floor angle horizontal leg by 10 mm when fitting patches at the corners as shown in Fig.4.5. Take a standard patch plate from stock or prepare the same from plate of requisite thickness.

- iii. Cut floor plates by 8mm for fitting new patch, as shown in Fig. 4.5. As an alternative, the patch plate may be made to rest over the floor plate, as shown in Fig. 4.6 & 4.7. In case, floor plates also require renewal, the width of the floor plates should be reduced to follow the arrangement shown in Fig. 4.8 & and 4.9. Secure the standard patch on the wagon by means of tack welding. Weld all around.
- iv. Rivet 2.5mm packing piece in position as shown in Fig. 4.10.
- v. Overlapping portions should be welded on both sides as shown in Fig. 4.11 and 4.12.
- vi. Ensure continuous welding without any craters.
- vii. In case of bulged panels, the patch should be riveted to the panels, as shown in Fig. 4.13.
- viii. Clean and repaint the welded portion at locations where paint has been burnt off.

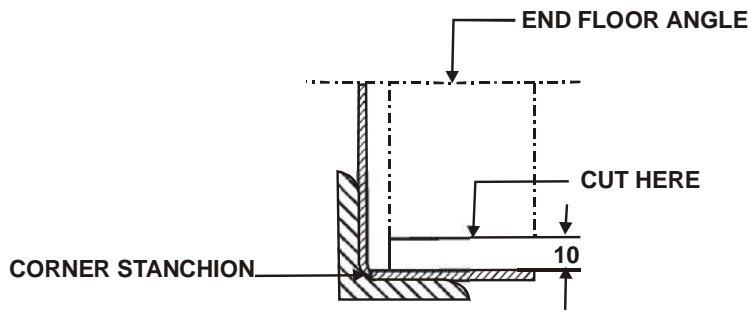


FIG. 4.5

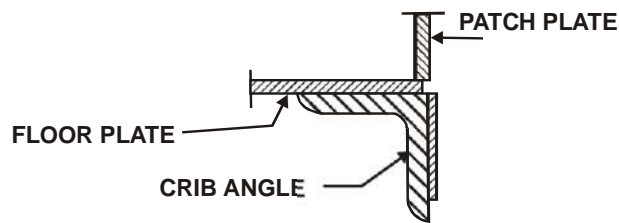


FIG. 4.6

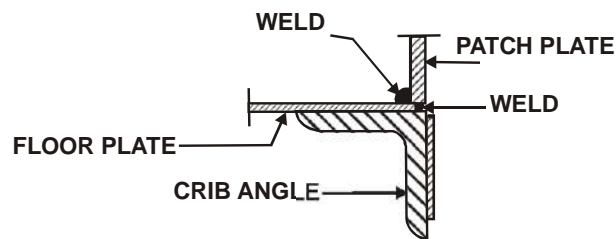


FIG. 4.7

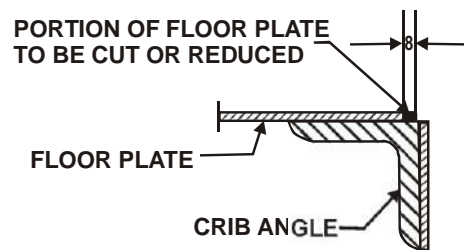


FIG. 4.8

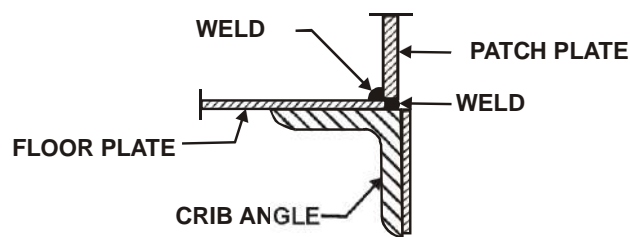


FIG. 4.9

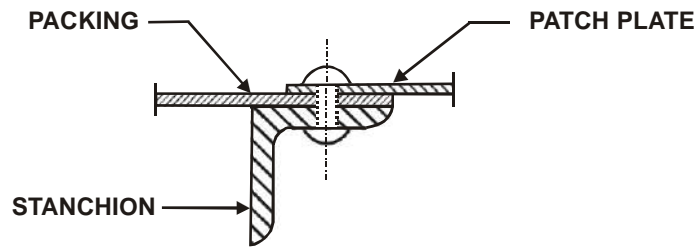


FIG 4.10

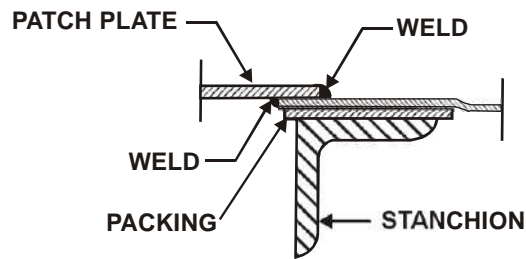


FIG 4.11

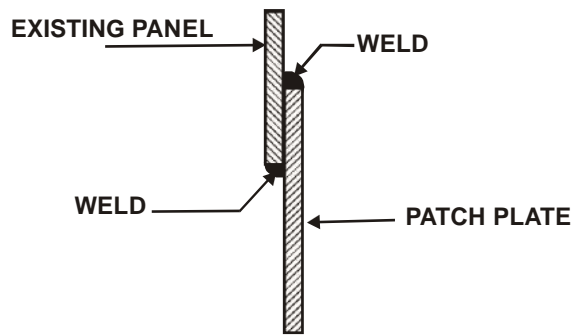


FIG 4.12

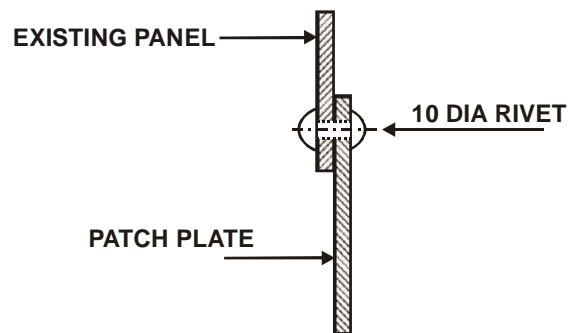


FIG 4.13

**410C. RIVETED PATCH**

Riveted patch should be avoided in workshops. These can however be applied in sickliness and ROH depots as per following procedure.

- i. Examine and mark the area of the patch to be cut.
- ii. Take a standard patch plate from stock or prepare the same from plate of requisite thickness.
- iii. Position the patch on the wagon and mark the location of the rivet holes.
- iv. Drill/punch the holes on both the patch and the wagon panel and secure the latter in position by temporary bolts and nuts.
- v. Rivet the patch in position.
- vi. Ensure that riveting is sound and with concentric snap heads, and also that mating edges are set properly leaving no gap in between.

**410D. REPAIRS TO BULGED ENDS**

If there are no serious damages to wagon ends other than bulging, the bulges can be effectively removed without dismantling. If two wagons with bulged ends are coupled together and a hydraulic jack is applied between them at the bulges, suitable packing being interposed between the jack and the wagon body. This method is particularly effective in dealing with dread-naught ends.

**410E. REPAIRS TO BODY STRUCTURAL MEMBERS (STANCHIONS, CARLINES AND COPINGS)**

- a. Damages to these members are usually due to rough handling, heavy shunting impacts or shifting of loads due to improper packing/stacking of the consignments. At first these components bulge out, but later even the rivets holding them to the underframe/superstructure members break out. It should be ensured that the bulging of these components does not cause infringements with the maximum moving dimensions. Bulging of these components by more than 25mm should be rectified. These components should be straightened without dismantling by pulling into correct position with the help of a chain and screw coupling or stripped and straightened either cold or by heating, as required and then riveted in position. Spot heating and cooling to straighten the stanchions can rectify bulging of all welded ends.
- b. In certain cases, these components may have developed cracks, or may have broken in pieces. Such of these components should be repaired by welding both the pieces and applying a stiffener angle prepared by bending a 6mm plate in the shape of an angle with its outer faces sitting flush in the inner profile of the member to be patched and welding it all round to the member. Elongated holes in these components should be filled up by welding and refilled.

**410F. WATER TIGHTENING OF WAGON**

Covered wagons must be kept watertight at all times. Covered wagons must be tested for water tightness at the time of leaving the workshop after POH or other repairs. All empty covered wagons attended to in sicklines, should also be tested for leaks, and made watertight by applying sealing compound before the onset of the monsoon season, a special drive should be instituted and sealing compound must be applied at

all points of covered wagon bodies, which are likely to leak particularly peripheries of riveted patches other overlaps and small holes.

Before the application of sealing compound, mechanical defects such as bulged panels severely distorted body structural members, gaping joints, loose rivets and other corroded areas must be attended to. It should be ensured that the surfaces are clean and dry before sealing compound is applied. An attempt must not be made to fill up large gaps or other openings with sealing compound. Holes more than 6 mm in diameter should be filled by rivets. Irregular openings and cuts with more than 25 mm length and 3 mm width should be repaired by patching or welding.

After a wagon has been made watertight, it should be marked "WT" with station code and date on the left-hand bottom corner of both sides.

#### **410G. REPAIRS TO DOORS AND DOOR FITTINGS (FOR MILD STEEL WAGONS)**

*The main defects arising in doors are:-*

- Distortion due to wedging or other mishandling
- Jamming of hinges
- Excessive clearances in hinges
- Inadequate overlap between flaps and door leaves
- Gaping of doors at the stanchions
- Distortion or breakage of tower bolts
- Breakage of hinges and
- Damage to gravity cotters, hooks and hasps.

Damaged doors of covered wagons are responsible for a very large proportion of claims due to wetting or pilferage of consignments. Warpage of flap doors is often responsible for jamming of flap door hinges. Special care must therefore, be taken in attending to doors.

Distorted or bulged doors must be taken down and straightened to ensure proper fit. Worn out hinges are responsible for sagging or gaping doors and inadequate overlap. Such hinges must be replaced with new or reconditioned ones.

Bent door stanchions and depressed crib angles must be straightened to ensure free functioning of doors and prevent gaping. Corroded crib angles must be cut out and replaced. Graphite grease should be introduced in all hinges, sliding cotters and other working parts.

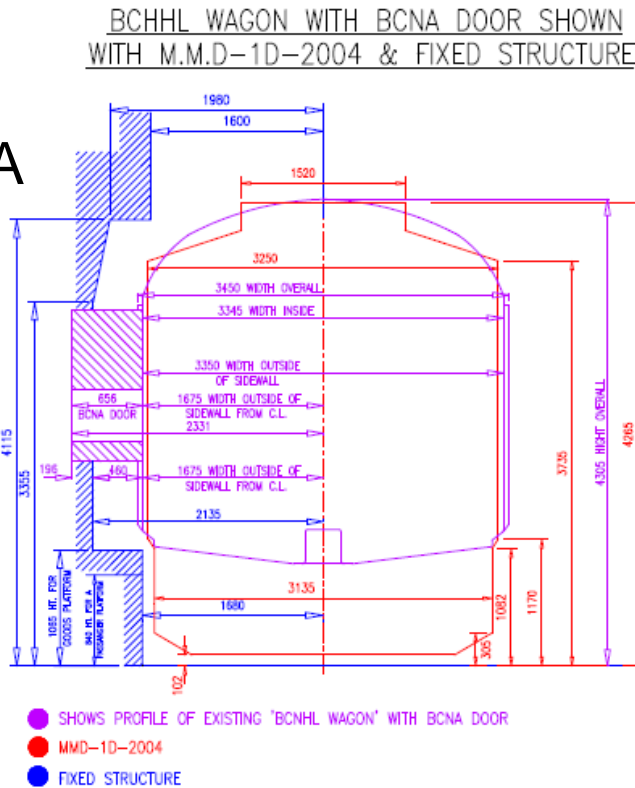
After repairs, doors must sit flush against striking plates with adequate overlap between leaves and without gaping at the stanchions or crib angles. Anti-bleeding devices and rain protection angles should also be checked and rectified where necessary.

In the case of hopper wagons, it should be ensured that when the doors are closed, no gap is left between the chute plate and frame, and that the operating gear works freely and is in good condition.

**410H. REPAIRS TO DOORS AND DOOR FITTINGS (FOR BCNHL WAGONS)**

**BCNHL** wagons have been fitted with doors which are different from conventional BCN doors. The first original design was initiated in May-2008, but some problems/defects were observed by the Zonal railways in field during loading unloading. The original(first) design is given in **photo-4.1**.

**BCNHL  
with BCNA  
door**



**BCNHL Door designs:**

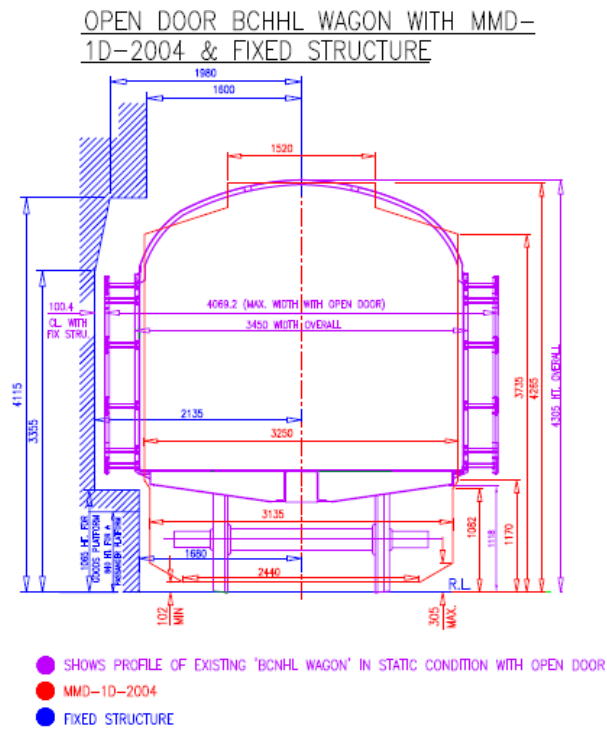
Original (First) Design (May'2008)



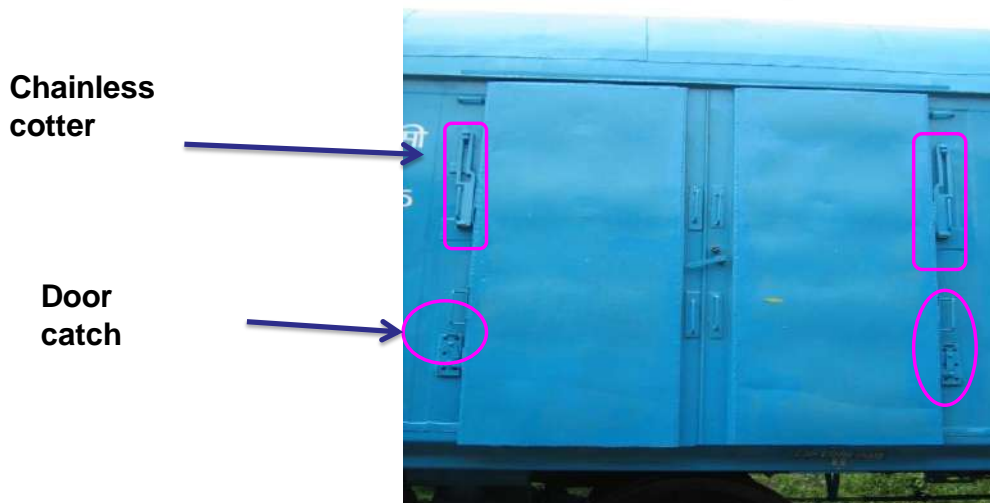
**Photo -4.1**



MMD  
&  
BCNHL

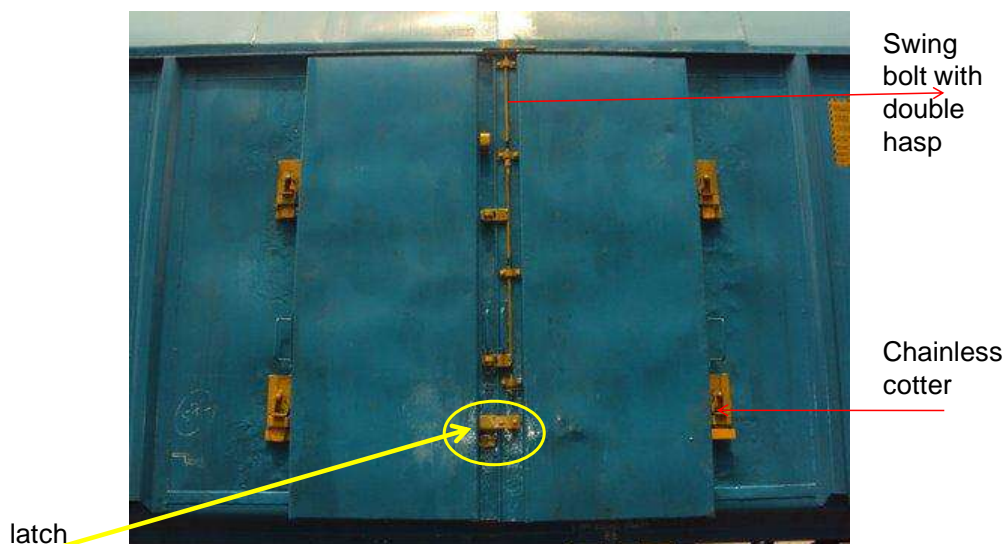


Observing problems in the field, design **Modification-I** was done in June-2009 vide RDSO drawing No. WD5-SRD-S-01 & S-02 and existing design was modified to eliminate gap between side wall and door at hinge, improving door securing & hence eliminating the possibility of door hitting & rain water seepage. See **photo-4.2**



**Photo-4.2**

Further after gaining experience, design modification-II was incorporated in June-2010 by providing tower-bolt on out side in place of inside the door. In this modification, small chainless cotter, (02 nos.) on outside were provided in place of existing long chainless cotters. See **photo-4.3**



Hinged Door- Modification-II-  
(Current, latest Design of Hinge Door).



Outer view of door locking arrangement



Inner view of additional door locking arrangement

**Photo- 4.3**

**B. Some other Door designs used in limited numbers on the wagons**

1. Design alteration (Pressed Door Design-4 hinges)-Variant-II was developed by RDSO in June-2009. See **photo-4.4**



**Photo -4.4**

- 2. Sliding door (Fabricated design) Bottom Roller design was developed by RDSO in August-2009 and was provided on trial on limited no. of wagons. See **photo-4.5**



**Photo -4.5**







- 3. Sliding door ( Pressed design) Top mounted Rollers on Guide channel was developed in April-2010 and was provided on the wagons on trial basis. See **photo-4.6**



**Photo -4.6**

### C. BCNHL POPULATION DISPERSION ( IN TERMS OF TYPE OF DOORS USED)

(Till the Rly Board Contract of -2012). See table below

BCNHL population dispersion								
S.No.	Door Design	Texmaco	HEI	Titagarh	BESCO	Modern	TOTAL	% of Total
1	ORIGINAL 	254	337	0	362	47	1000	12.6
2	MOD-I 	1688	0	1255	17	104	3064	38.7
3	BESCO DESIGN 	0	0	100	414	0	514	6.5
4	MOD-II 	921	592	302	210	960	2985	37.7
5	SLIDING (TWL) 	0	0	58	0	0	58	0.7
6	SLIDING (Texmaco) 	300	0	0	0	0	300	3.8
<b>TOTAL</b>							<b>7921</b>	<b>100.0</b>

### D. NEED OF DOOR MODIFICATIONS BY RDSO

Owing to severe Field issues in earlier versions (Original and Mod-I), Zonal Railways have already been advised to undertake retro fitment of modified locking arrangement (As per Mod-II) in the earlier versions of door assemblies. For above retro fitment, RDSO has issued procedure and drawing No. WD-10036-S-01/WD-06076-S-13 in June-2010.

### E. PROVISION OF MODIFIED DOORS IN NEW BCNHL WAGONS

From amongst the designs tried in the field, the door design with top mounted rollers ( 300 Wagons) have performed with the least field problems. This door design with modifications to address all field issues has been standardised for new BCNHL wagons. See **Photo-07**



**Photo -07**

### F. DESIGN MODIFICATIONS IN SINGLE PIECE PRESSED SLIDING DOOR (BCNHL DESIGN-D WAGONS).

#### (a) Roller Support Bracket:

The Roller support bracket, welding has been strengthened.

#### (b) Roller Design & associated changes in guide channel:

**b.1** The roller diameter increased to in order to ensure a roller overlap (with the guide channel) of 12mm in place of the existing 8 mm.

**b.2** The roller profile be modified from a flat profile to a convex profile, so that the existing line contact of the roller-guide channel, be modified to a point contact, to ensure smoother sliding motion of the door.

**b.3** The number & location of rollers be modified from the existing three rollers, equidistant along the door width to FOUR rollers, with two rollers each in the front & end of the door width.

#### (c) Rain Protector Strengthening:

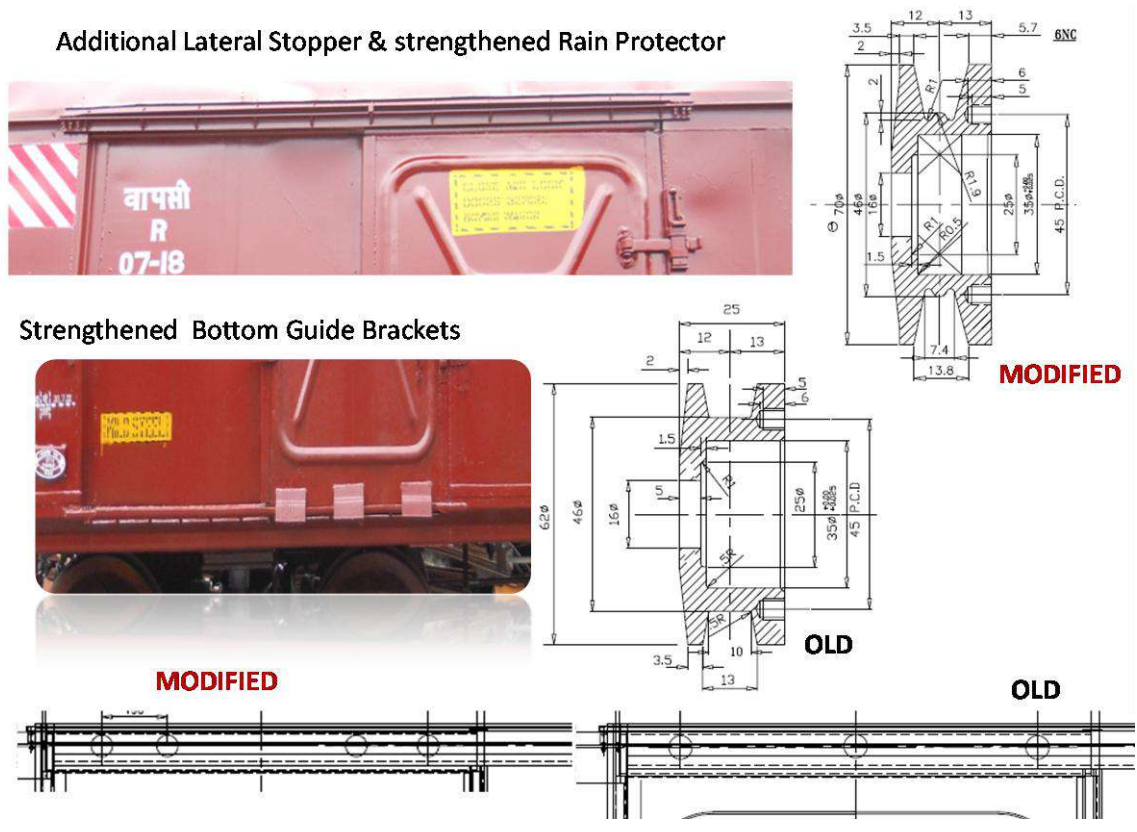
The thickness of the rain protector channel be modified from the existing 2.5mm to 4mm. In order to provide support, additional ribs be provided, in the rain protector member.

**(d) Provision of additional lateral stop member:**

In order to prevent a lateral falling/ movement of door sheet, an additional lateral stop member, needs to be provided.

**(e) Support in Bottom guide:**

To prevent blockage of the bottom guide owing to loose cement, a continuous slot has been provided. In order to provide strength to the bottom support, strengthening of the support be done by providing ribs at a pitch of 180mm between the auxiliary sole bar & the vertical face of the inside sole bar channel.



**(f) Back Sheet on door:**

The pressed impression on the door, results in a cavity that could lock/entangle loaded commodity bags, during the sliding motion of the door. To prevent the above, the depressed cavity be covered using off-cuts of the 1.6mm thick sheet. Sections of suitable sizes of this sheet (1.6mm thick) be welded on the inside of the pressed door sheet to cover the portion of the pressing & ensure a smooth door surface on the inside.

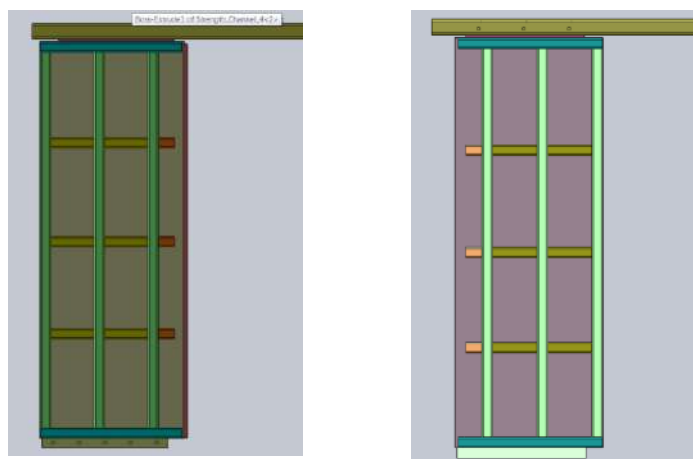
**(g) Strengthening the Bottom part of door sheet:**

During service in the field, the bottom part of the door, is reported to working-out from the provided slot. To strengthen the bottom portion of the door & to prevent its working out, a 6mm flat be welded at the bottom portion of the door sheet.

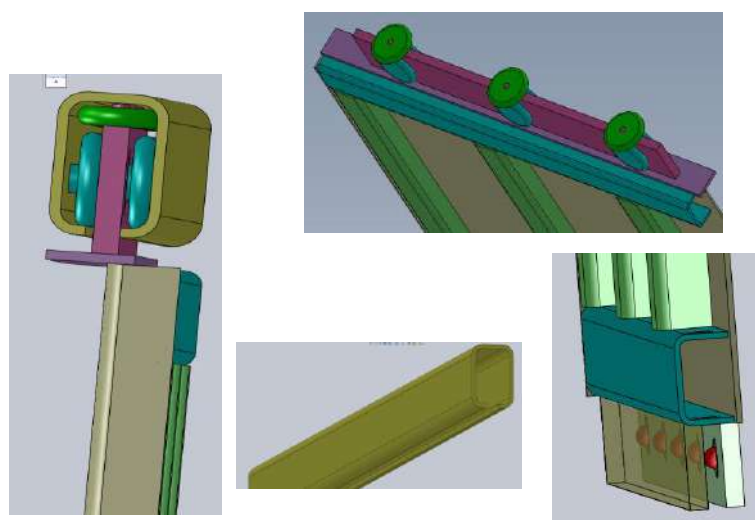
## G. RETROFITABLE SLIDING DOOR FOR OLDER BCNHL WAGONS

For older BCNHL wagons (manufactured prior to June'2010), & NECESSARILY warranting door replacements, a retrofitable two-part door design has been developed.

### Retrofit-able Sliding Door



### Retrofit-able Sliding Door



#### Highlights of the Retrofitable sliding door design:

- 2 Part Sliding Door.
- Sliding using 3 sets of rollers (on each door ) mounted on top portion of door.
- Door Supported at Bottom.
- Top pivoted door with ability to move laterally (on being pushed by loaded bags).
- Retrofitable design. Can be fabricated as a unit & be mounted on existing BCNHL wagons.

- Lower Weight (75 kgs of each door vs 105 kgs of Hinge door).
- No chances of hitting any fixed structure, since lateral projection less than side stanchions.
- Secured locking arrangement, easily operational from non-platform line.
- Ease of Loading/ Unloading owing to Sliding Door design.
- Ease of Maintenance- rollers fitted in guide channel, with end covers which can be replaced/ opened easily.
- Bearings in Rollers provided with dust cover & concealed to prevent ingress of dirt.
- To facilitate lateral movement transfer balls provided at door bottom.

#### **410L. CLEANING, SURFACE PREPARATION AND PAINTING**

The correct sequence and procedure for cleaning, preparation of metal surfaces to be painted and the painting thereof;

##### **a. Preparation of surface before painting**

The purpose of cleaning is to remove dirt, oil, grease, rust and other contaminants, which would prevent the paint film from adhering to the metal or would provide a nucleus for commencement of corrosion.

Cleaning by hammering, chiselling or scraping is unsatisfactory and should not be resorted to. The surface cleaning may be done by vigorously scrubbing with a stiff brush. All welded parts and adjacent surfaces should be thoroughly cleaned to remove residual alkaline flux and washed with hot water.

- b. A coat of priming paint should be applied immediately after the surface has been cleaned and dried. A delay of more than 4 hours may result in development of fresh rust on the surface. A second coat of primer must be given when the first coat is dry. Painting must be done under cover in a shed or shop. The painted surfaces must remain under cover until the paint is dry.
- c. Panel patches and riveting strips must be cleaned, as prescribed above, and given two coats of primer before storage or fitment.
- d. After completion of all repairs a final coat of finishing paint should be given to all painted surfaces.
- e. When the paint film is only partially damaged, it should be touched up with one coat of primer and then given the finishing coat.
- f. Surfaces, which will become inaccessible after assembly must be given complete painting before assembly.



#### **411. REPAIRS AND MAINTENANCE IN WORKSHOPS DURING POH AND NPOH**

- a. For body repairs, same procedure as described in para 410 A to 410 I above is to be followed.

**Note :-** The detailed procedure for painting and specifications for different coats of paint are given in general standard specification G-72 read with latest amendments which may be referred to for more details.

*In addition to the above, following items to be carried out during POH in workshops.*

**b. Lettering**

Lettering to be carried out as per IRCA Part III Rule 2.4 by stencilling the relevant figures.

- c. Punching of wagon particulars.  
d. PR plate  
e. Tare weight to be measured after POH and it should be marked up to one decimal.

#### **412. IMPORTANT PRECAUTIONS TO BE TAKEN WHILE CARRYING OUT WELDING**

Welding entails the risk of fire if combustible materials are present near the area being welded. To prevent such accidents, the following precautions must be taken:

**A. Loaded wagons**

It should be ensured that the content is not inflammable. Should the contents be inflammable they must be transhipped before welding is attempted.

Tank wagons should never be welded when loaded.

**B. Empty wagons**

It should first be ensured that no portion of an inflammable consignment packing material or dunnage is present in the area to be welded.

Empty tank wagons should be given welding repairs only in depots specially equipped for this purpose and only after thorough steam cleaning and testing to ensure that there are no inflammable/explosive vapours left.

**C. Wagons fitted with CTRBs**

No welding should be attempted without effectively earthing the member or component to be welded. Neglect in taking this precaution will result in passage of the return current through the CTRB, which may suffer severe damage leading to premature failure.

### **413. IMPORTANT DO'S AND DON'TS**

#### **Do's**

- i. Ensure that you have the proper tools required for the job. Use of improper tools can make matters worse.
- ii. Ensure that tools and equipment are in good condition.
- iii. See that rivet heads are properly formed with correctly profiled snaps.
- iv. While fitting patches to structural members, ensure that the pitch of rivets conforms to the original pitch in the structural members.
- v. See that doors are provided with all required fittings so as to ensure proper securing and prevent unauthorised opening.
- vi. Ensure that door hooks are intact and so placed that they will engage with the door eye in open position.
- vii. Ensure that all chains links and other attachments are in position and in working order.

#### **Don'ts**

- i. Do not use patches of less thickness than the original panel.
- ii. Do not patch existing patches.
- iii. Do not build up perforations in panel due to corrosion. Cut out and fit a new patch.
- iv. Do not permit empty wagons to run with open doors.
- v. Do not permit loaded wagons to run without properly secured doors.
- vi. Do not allow wagons with inadequately secured/lashed consignments.

### **414 MAINTENANCE OF STAINLESS STEEL WAGONS**

The Maintenance of Stainless Steel Wagons is covered in **APPENDIX-VI**

### **415 UPGRADED REHABILITATION OF BOXN TO BOXNR**

Vide Rly. Board's letter no. 2005/ M (N)/204/2 (RSP) dated 02.11.07 it has been decided that rehabilitation of BOXN wagons would be done to BOXNR design (stainless steel body).

*The constructional differences between BOXN & BOXNR are as follows:*

**A. TECHNICAL REQUIREMENTS FOR UPGRADED REHABILITATION OF BOXN WAGONS TO BOXNR SHALL BE DONE AS PER RDSO SPEC. NO. WD.16.BOXNR-2010 OR LATEST**

- After the rehabilitation and upgradation, the wagon shall be marked as BOXNR in place of BOXN. The major differences in constructional features of BOXN & BOXNR are as under:

**SIDE WALL**

	<b>BOXN</b>		<b>BOXNR</b>
(i)	Material mild steel	(i)	Material stainless steel(IRS:M44)
(ii)	Provided with 6 Nos. of side stanchions with 8mm thick hat section ( on one side)	(ii)	Provided with 9 Nos. of side stanchions with 6mm thick CRF hat section (on one side)
(iii)	Side sheets of 5mm thickness	(iii)	Side sheets of 3 mm thickness.
(vi)	Inside height of side wall is 1950mm from floor level.	(iv)	Inside height is 2127mm from floor level.
(v)	Two Nos. middle coping provided in sidewall.	(v)	Middle copings are not provided in side walls, except at corner side panels.
(vi)	Top coping provided with ISMC-100	(vi)	Top coping provided with press section of BOX 100x100x6mm thick.
(vii)	Side stanchion riveted with sole bar with two rows rivets.	(vii)	Side stanchion huck bolted with sole bar with single row.

**DOOR PLATE**

(i)	Door Plate provided with Mild Steel for 5 mm thickness	(i)	Door plate provided with stainless steel of 4 mm thickness.
-----	--------------------------------------------------------	-----	-------------------------------------------------------------

**END WALL**

(i)	Made with mild steel.	(i)	Made with stainless steel (IRS:M44)
(ii)	Each End wall provided with 4 Nos. of End stanchions of ISMC-150mm.	(ii)	End wall provided Two end stanchion in three pieces and two middle coping of Hat section 6 mm thickness.
(iii)	End top coping provided with ISMC-150 channel.	(iii)	End top coping provided with CRF section of BOX 100x100x6mm thickness
(iv)	End Sheet provided with 5 mm thick	(iv)	End Sheet provided with 3 mm thick

**FLOOR PLATE**

(i)	Floor Plate provided with Mild Steel for 6 mm thickness	(i)	Floor plate provided with stainless steel of 4 mm thickness.
-----	---------------------------------------------------------	-----	--------------------------------------------------------------

## B. DESCRIPTION OF WORK:

The rehabilitation of BOXN wagon body by using of CRF section (to RDSO's specification no. WD- 01 – CRF – 08 or latest) and stainless steel (IRS:M 44: 97 latest revision) will provide additional strength to body and reduce corrosion. The volume will also increase to fully utilize the capacity upto 22.9 Tonne axle load for coal.

### Note:

**The procedure, precautions and facilities required for repairs to Stainless steel wagons will be similar to above upgradation.**

## 416 LOCK BOLTS

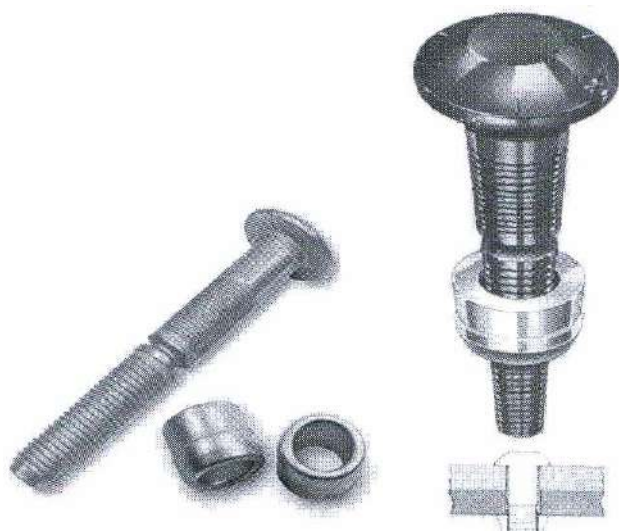
Almost all new wagons specially stainless steel wagons are provided with lock bolting instead of riveting. In repair/maintenance CP top of all wagons irrespective of materials are to be lock bolted. entire lock bolting is to be done with zinc plated/galvanized lock bolts (grade-8) having a minimum yield strength of 250 N/mm<sup>2</sup>.

Lock Bolts have been introduced in the fabrication of Wagons. Lock bolt fasteners consist of Lock bolt pin and collar, and are installed with the help of special installation tools, as follows-

- Lock bolt pin is placed in drilled hole, and collar is placed onto the lock bolt pin.
- Installation tool engages and pulls the lock bolts pin.
- Tool swages the collar onto lock bolt grooves.
- Pin tail breaks off the lock bolt pin.

*The advantages of Lock bolts are –*

- High strength
- Vibration resistant
- Fast and easy installation
- Maintenance free



**FIG. 4.14 LOCK BOLT**

**a) Proper Installation of lock bolts:-*****It should be ensured that:***

- (i) The collar of lock bolt are completely swaged. The collar of lock bolt fasteners not completely swaged may be causes of improper tool operation or worn anvil in nose.
- (ii) The pintail of fastener break without fail. The pintail of fastener fails to break due to improper installation/incorrect fasteners.
- (iii) After breaking of pintail, the extruded/projected portion of lock bolt should be in the range of 2.00 to 10 mm and collar should always be on annular groove of lock bolt.
- (iv) Mismatch of holes to be reamed properly to align and gas cutting to match holes is strictly prohibited.

**b) Recommendations for Zonal Railways/ ROH depots:**

**(RDSO vide letter No.MW/Lock Bolt dated 21.03.2014)**

- The Yard examination/ rake inspection should include checks for any failed/missing/ loose Lock bolts/ Collars, especially in critical locations. Necessary repair/ re-installation of correct lock bolt/ collars, should be subsequently ensured.
- Lock bolts, if found failed/ missing should not be replaced with bolt-nut. Such a fitment, would invariably render the assembly differentially fastened, leading to consequential failure of the assembly/ component.
- During procurement of lock bolts/ collars, pre-despatch inspection of lock bolts/collars should be specified. WTC detailing functional properties, detailed in RDSO's guideline or RITES inspection covering properties detailed in RDSO's circulated guideline, should be ensured/ specified in PO's.
- Lock bolt/ Collars failure noticed in wagons, should necessarily be reported to RDSO. For the guidance of ZR's the head marking details in lock bolts of all the three known sources are detailed in Annexure-VI. Records of the make of lock bolt/ collars, noticed issues in fitment & any probable reasons for noticed failure, should also be communicated. In case of under-warranty wagons, necessary warranty claims, should *also be lodged, as per defined procedure/process.*

## 417 NEW WAGON NUMBERING SCHEME

Monitoring and liquidating overage arrears of rolling stock is a focus area in the interest of safety of train operations. However, some of the Railways have reported difficulty in ascertaining the age of wagons where the manufacturer's plate is missing. Also computerization of wagon data is becoming cumbersome with development of various versions in a category e.g. BG bogie open wagons BOXN, BOXNHS, BOXNAHA, BOXNCR, BOXNHL, BOXNR and BOXNLW are being clubbed together by the computer cell and shown as BOXN in the holding. To overcome the above-mentioned problems and to facilitate computerization of the wagon data base, a new wagon numbering system was introduced by Railway Board as per letter no. 2000/M(N)/60/2/wagon census. Dated 4<sup>th</sup> July, 2003

In the new scheme, the wagon number shall consist of 11 digits as follows:

Type of wagon		Owning Railway		Year of Manufacture		Individual Wagon Number				Check Digit
C1	C2	C3	C4	C5	C6	C7	C8	C9	C10	C11

The codification for various types of wagons, owning railways, year of manufacture and individual wagon no. are as follows:

### Type of Wagon Codes (C1, C2)

<b>i)</b>	<b>Open Wagon</b>	<b>Code allotted</b>	<b>10 to 29</b>
	BOXN	10	
	BOXNHA	11	
	BOXNHS	12	
	BOXNCR	13	
	BOXNLW	14	
	BOXNB	15	
	BOXNF	16	
	BOXNG	17	
	BOY	18	
	BOST	19	
	BOXNAL	20	
BOXN-HL	22		
<b>ii)</b>	<b>Covered Wagon</b>	<b>Code allotted</b>	<b>30 to 39</b>
	BCNA	30	
	BCNAHS	31	
	BCCNR	32	
	BCN-HL	33	
<b>iii)</b>	<b>Tank Wagon</b>	<b>Code allotted</b>	<b>40 to 54</b>
	BTPN	40	
	BTPNHS	41	
	BTPGLN	42	
	BTALN	43	
	BTCS	44	
	BTPH	45	
	BTAP	46	

<b>iv)</b>	<b>Flat Wagon</b>	<b>Code allotted</b>	<b>55 to 69</b>
	BRNA	55	
	BRNAHS	56	
	BFNS	57	
	BOMN	58	
	BRSTH	59	
	BFAT	60	
	BLCA	61	
BLCB	62		

<b>v)</b>	<b>Hopper Wagon</b>	<b>Code allotted</b>	<b>70 to 79</b>
	BOBYN	70	
	BOBYNHS	71	
	BOBRN	72	
	BOBRNHS	73	
	BOBRAL	74	

<b>vi)</b>	<b>Well Wagon</b>	<b>Code allotted</b>	<b>80 to 84</b>
	BWTB	<b>80</b>	

<b>vii)</b>	<b>Brake Van</b>	<b>Code allotted</b>	<b>85 to 89</b>
	BVZC	85	
	BVZI	86	

#### **OWNERSHIP (RAILWAYS') CODES (C3, C4) :**

<b>SNo.</b>	<b>Name of Railways</b>	<b>Numerical codes</b>
1	Central Railway	01
2	Eastern Railway	02
3	Northern Railway	03
4	North East Railway	04
5	Northeast Frontier Railway	05
6	Southern Railway	06
7	South Eastern Railway	07
8	Western Railway	08
9	South Central Railway	09
10	East Central Railway	10
11	North Western Railway	11
12	East coast Railway	12
13	North Central Railway	13
14	South East Central Railway	14
15	South Western Railway	15
16	West Central Railway	16
17	Wagons owned by CONCOR	25
18	Wagons owned by other private parties	26

**YEAR OF MANUFACTURE CODE (C5, C6):**

This will consist of last two digits of the year of manufacture. For example wagon manufacture in 2016 will have code 16.

**INDIVIDUAL WAGON No. (C7, C8, C9, C10):**

This will be running serial number from 0001 to 9999. Numbers 0001 to 0999 will be departmental stock and 1000 to 9999 will be other (traffic) stock. This will be running number irrespective of year. For departmental, after 0999, the number will begin from 0001. For others, after 9999, the number will begin from 1000.

The series will not change with type of wagon. For example on ECR if 1001 is BOXNHS next wagon which may be BCNHS will be 1002.

**CHECK DIGIT – Method of calculation**

The CHECK DIGIT for each wagon is calculated using a six-step algorithm based on ten digit wagon number arrived at as indicated below.

<b>Type of wagon</b>		<b>Railway Code</b>		<b>Year of Manufacture</b>		<b>Individual wagon Number</b>				<b>Check Digit</b>
C1	C2	C3	C4	C5	C6	C7	C8	C9	C10	C11

Step – 1 Starting from the left, add all the characters in the even position.  
 $S\ 1 = C2 + C4 + C6 + C8 + C10$

Step – 2 Multiply the sum by 3 to get 3. S1

Step – 3 Starting from the left, add all the characters in the odd position.  
 $S\ 2 = C1 + C3 + C5 + C7 + C9$

Step – 4 Add the sum of step 2 to the sum of step 3 to get  $S4 = 3S\ 1 + S2$

Step – 5 Round this total up to the next multiple of 10

Step – 6 The check digit is the number required to be added to round up to the next multiple of 10.

**\* NOTE:** *If the total in S4 is already of 10, then the check digit is 0.*





*( MAINTENANCE MANUAL FOR WAGONS- 2015 )*

# **CHAPTER – 5**

# **UNDER FRAME**



## CHAPTER 5

### UNDER FRAME

#### 501. GENERAL

The type and size of a particular underframe is intimately related to the type and design of a wagon, as it constitutes the main load bearing sub-assembly for the vehicle. The overall dimensions and design of this structure take into account the quantum and pattern of loading on the vehicle as well as the track considerations. This in turn determines the permissible wheel base of a bogie wagon would be required for the purpose of carrying the required load. Accordingly, while designing an underframe, the loading per meter is also taken into account as this is to be permitted by the type of track available. The buffing and impact loads also govern the strength of the underframe and the shunting speeds permitted for the marshalling of the goods stock. In the case of bogie wagons, the load transfer to the bogie frame is by means of pivot arrangement and thus the bogie frame also assumes an equally important function.

#### 502. GENERAL CONSTRUCTION OF BG WAGON UNDERFRAME

A. The main members of a typical conventional BG wagon underframe are as under:

- i. Sole bars
- ii. Head stock
- iii. Longitudinal
- iv. Cross bars
- v. Bolster
- vi. Floor
- vii. Crib angle
- viii. End angle
- ix. Gusset plates and knees
- x. Centre Sill

B. The main underframe of a vehicle generally consists of two outer longitudinal member's viz. Sole bars and the two head stocks which are strengthened by two middle longitudinals and various cross members. The diagonals and gusset plates protect the under frame against diagonal deflection and help in absorbing and distributing the buffing loads over different members. As already mentioned, the gusset plates and knees are provided at critical locations to impart additional strength to the joints. The whole structure is so designed that various loads are uniformly distributed and no single member has to bear excessive load than designed for.

Various rolled/CRF sections are used for the underframe members. Channel/CRF/Press Z-section/Hat section are generally used for headstock and sole bars for facilitating fitment of Z-Sections etc. are used for centre sills. Welding is generally used for joining the underframe members. But in earlier wagons, riveting had been used for joining these members. In the case of bogie wagons, the underframe has comparatively stronger cross members, known as bolsters, for fitting the upper centre pivot casting, which rests on the bogie pivot.

C. All under-frames are given an initial camber at the time of manufacture so that under actual loading conditions, these do not sag.

D. The under-frame and all its members are necessarily to be true and square and these should conform to the manufacturing tolerances.

**E. The following tolerances are permitted in the new wagon construction:**

i)	Inside length	+ 5 mm (riveted) - 5 mm + 7 mm (welded) - 3 mm
ii)	Inside width	+ 3 mm - 3 mm
iii)	Inside height	+ 3 mm - 3 mm
iv)	Difference between diagonals	
	a. Under frame	5 mm
	b. Body side	5 mm
	c. Body end	5 mm
	d. Door opening	4 mm
	e. Door	3 mm
v)	Distance between bogie pivot centres	+ 3 mm (riveted) - 3 mm + 5 mm (welded) - 2 mm
vi)	Distance between bogie pivot centre and adjacent headstock	+2 mm - 2 mm
vii)	Distance between stanchions:	
	(a) Body side	+ 3 mm - 3 mm
	(b) Body end	+1.5 mm - 1.5 mm
viii)	Door opening (vertical or horizontal)	+ 0 mm - 3 mm
ix)	Door length	+ 5 mm - 0 mm
x)	Door width	+ 3 mm - 0 mm
xi)	Distance between door centre line to centre line of door hinge	+ 1.5 mm - 1.5 mm
xii)	Coupler height from rail level in case the bogies are fabricated by the wagon builder himself.	+ 0 mm - 5 mm
xiii)	Coupler height from bogie top pivot in case bogies are provided as free supply items.	+ 0 mm - 3 mm
xiv)	Tolerances on dimensions of non-pressure tank wagon barrels shall be as under:	
	a) Length of barrel measured over the centre of the two dished ends.	+ 10mm/-3mm

- |                               |             |
|-------------------------------|-------------|
| b) Diameter including ovality | + 3mm/-3 mm |
| c) Inside dia of man hole     | + 3mm/-3 mm |
| d) Height of dome             | + 3mm/-3 mm |

**NOTE:** Butting faces of two courses or a barrel course and dished end should be aligned to + 1 mm accuracy before welding.

- F. The other major sub-assemblies fitted to the underframe are as under:
- i. Draw gear/CBC sub assembly
  - ii. Container locking/anchoring arrangement (on container flats only).
  - iii. Side stanchions & lashing chains.
  - iv. Door operating mechanism on hopper wagons.
  - v. Top centre pivot
- G. The underframe is main load bearing member in the vehicle which is not only subjected to static loads but also dynamic impacts owing to the unevenness in the track. In addition to this, it has to successfully withstand heavy buffing impacts during the course of marshalling as well as heavy jerks have to be sustained by the draw gear at the time of starting of goods trains. Hence in order to ensure safe and smooth running of vehicles, the maintenance of underframe has to be done very carefully.
- H. It is therefore the duty of all supervisors both in workshops and divisions, to ensure that a thorough inspection of underframe is carried out at the time of POH. Other major repairs and all defects and deficiencies that come to notice must be given meticulous and thorough attention. The defects and deficiencies generally noticed together with recommended repair practices have been discussed in detail in this chapter.

Figures of the some typical BG bogie underframe are given at Fig. 5.11 to 5.13.

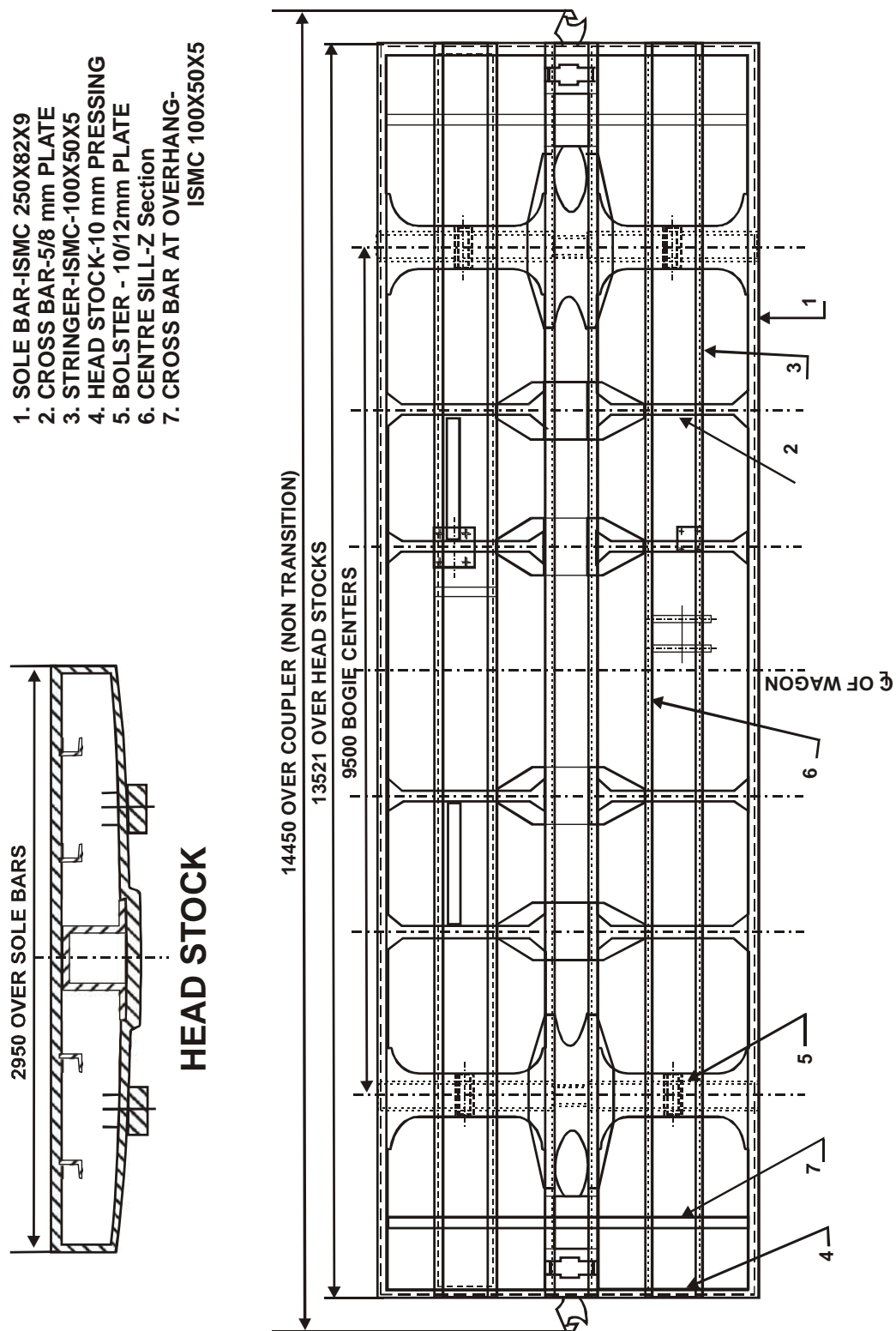
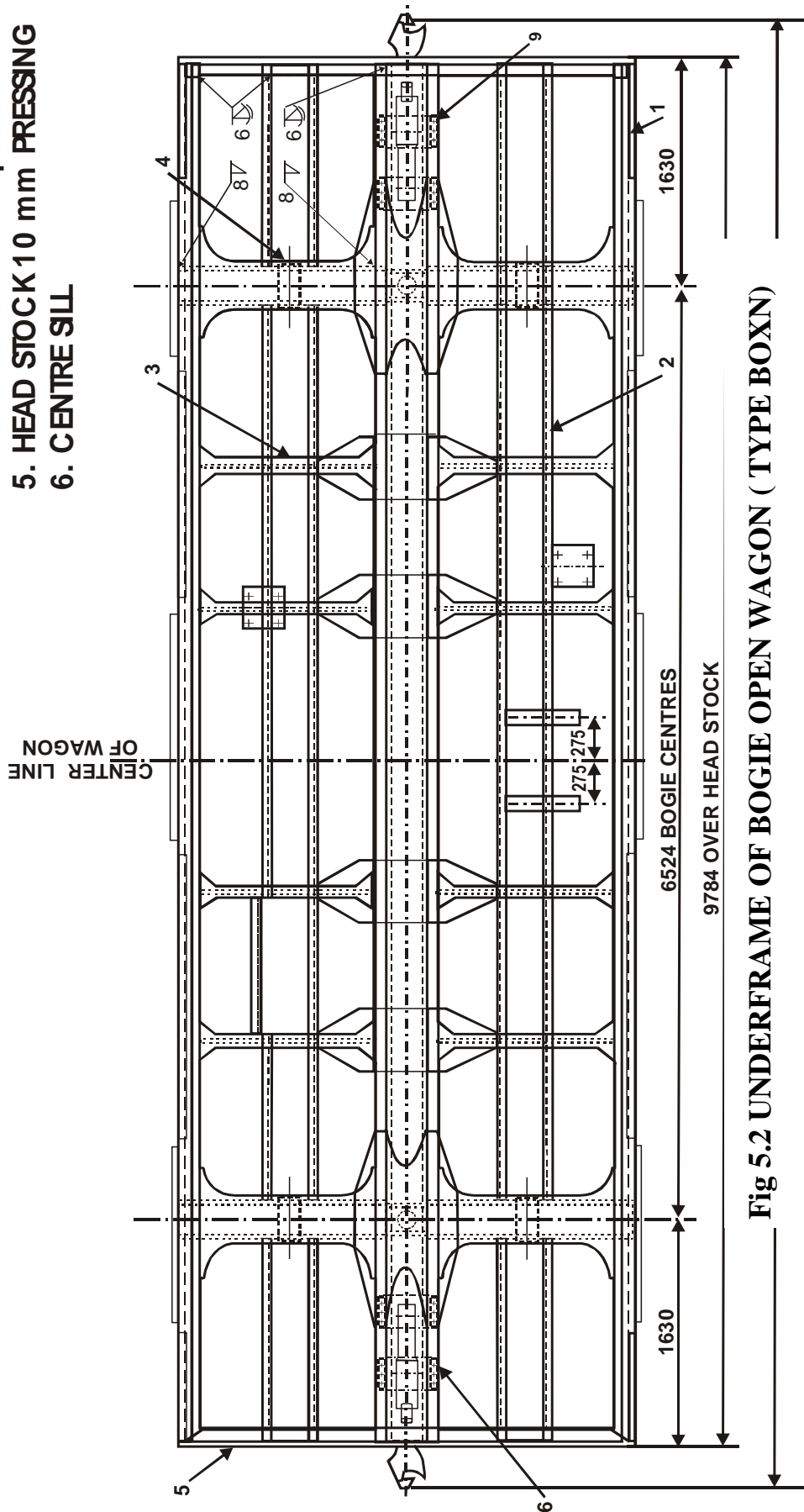


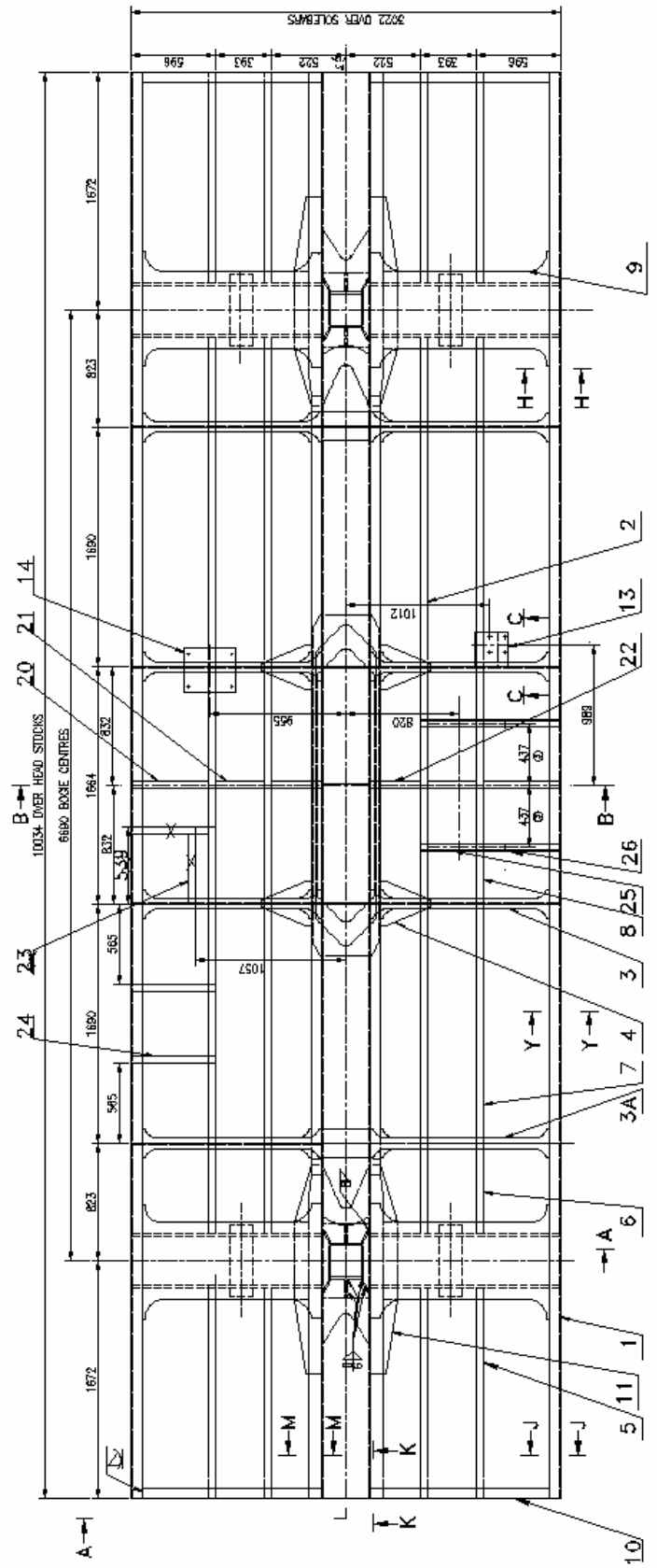
Fig. 5.1 BG WAGON TYPE “BCNA”

- 1. CROSS BAR 5/8 mm plate
- 4. BOLSTER 10/12 mm plate
- 5. HEAD STOCK 10 mm PRESSING
- 6. CENTRE SILL



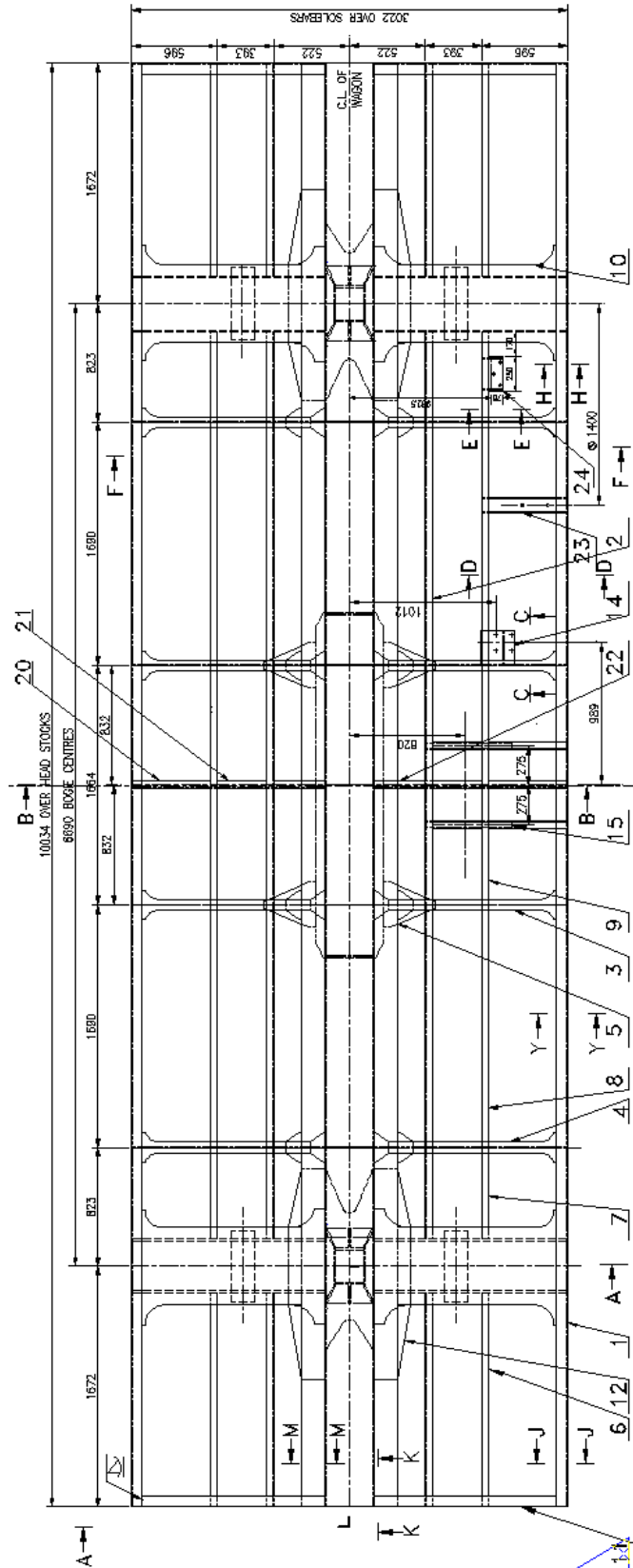
**Fig 5.2 UNDERFRAME OF BOGIE OPEN WAGON ( TYPE BOXN)**

**UNDERFRAME OF BOGIE OPEN WAGON (TYPE BOXN)**

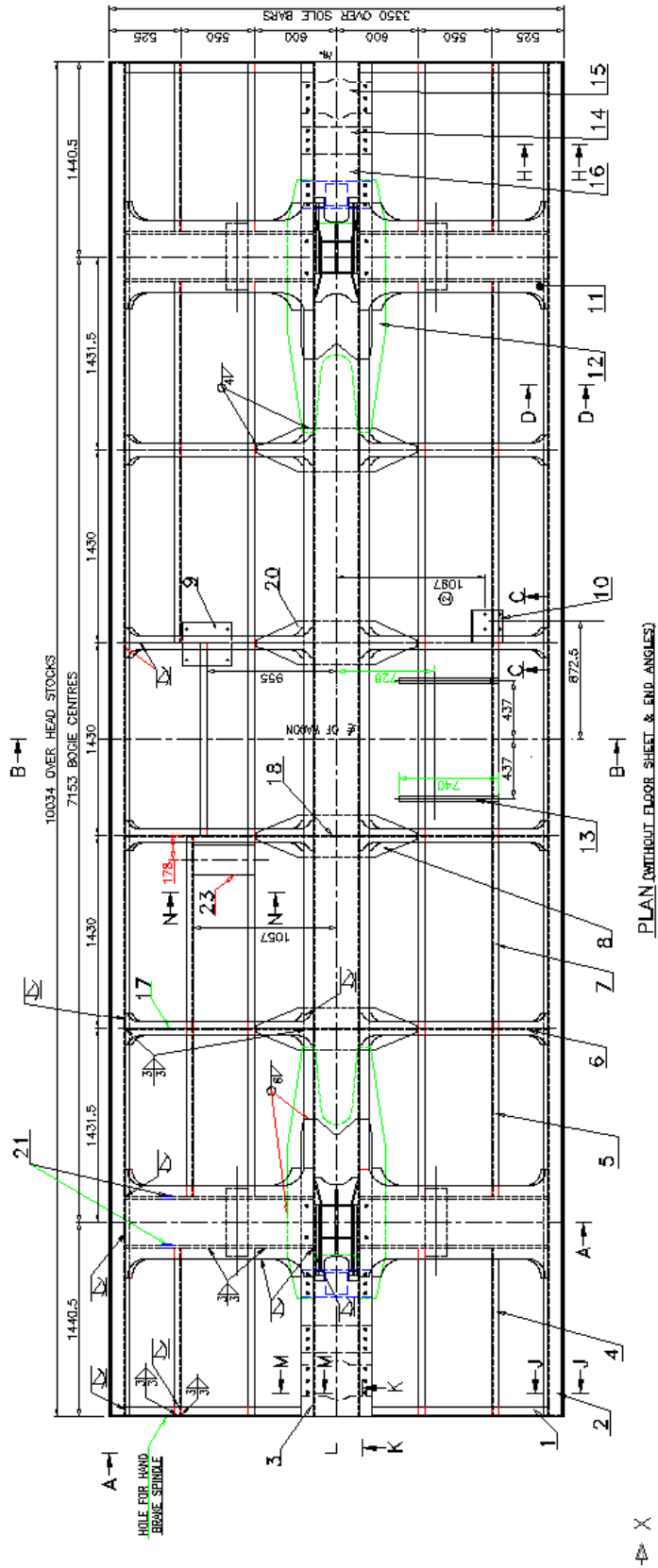


**Fig. 5.3 BOGIE OPEN WAGON TYPE 'BOXNHL' UNDERFRAME ARRANGEMENT**





**Fig 5.4 BOGIE OPEN WAGON TYPE 'BOXNHL (MBS)' UNDERFRAME ARRANGEMENT**



**Fig 5.5 BOGIE COVERRD WAGON TYPE 'BCNHL' UNDERFRAME ARRANGEMENT**

### **503. NEED OF THE REPAIRS TO BOGIE WAGON UNDERFRAME FOR MILD STEEL WAGONS**

- a. The underframe is built up of suitable rolled and pressed steel sections welded together. In earlier design underframe members were riveted construction by providing gussets, knees etc. It is a general practice to provide a positive camber in the underframe to obviate any chances of sagging after loading in service. This is necessary since the underframe of a bogie wagon is considerably longer than that of a four wheeler.
- b. The general damages to the headstock and other under frame members in bogie wagons are attended as per para 506 to 508. Some of these underframes are susceptible to development of cracks at side bearer location on the underframe bolster bottom flange. The repair procedure for this defect is given in RDSO technical pamphlets WM-74002 and 74003.
- c. Pressings of the head stock get damaged and at the time of POH they are invariably required to be stripped, straightened and refitted, for proper head stock alignment. In case head stock pressings are badly damaged, these should be replaced. It is also a good practice to keep stock of some spare head stock pressings to reduce the cycle time and the damaged ones can then be brought into reuse after repairs in the blacksmith shop.
- d. Centre sills, of bogie wagons, are generally fabricated with rolled Z-Section. In service, centre sills are not damaged. However, some times due to accident or over loading, centre sills may get damaged. Such center sills should be repaired as per RDSO Drg.No.WD-99031-S-1.
- e. In case of BRN wagons, the problem of breakage/detachment of fixed ends/headstock and sagging of sole bar/centre girder was noticed within first POH period. RDSO vide letter no.MW/BRN Dt. 7.1.99 asked Railways to modify the wagon to arrest such failures. These modifications are shown in RDSO Drg.No.WD-95010-S-1,S-2 and S-3. Procedure for re-cambering of bogie Rail wagon type BRN/BRNA/BRNHS as per RDSO pamphlet No.G-107 to be followed

### **504. REPAIR PROCEDURE**

#### **A. Inspection of underframe**

At the time of POH, the underframe is to be inspected in respect of following points specifically, as the underframe is the most important sub assembly of the wagon which imparts necessary rigidity to the wagon body as a whole.

##### **a) Rivets/Lock bolts**

All the rivets/Lock bolts specifically those of axle guard, scroll irons, head stock, stanchions and knees joining the main members are checked for looseness. Ensure that these are not broken. All slack/broken rivets/lock bolts are to be replaced by sound ones at the time of POH.

##### **b) Cracks**

The underframe is also inspected for any cracks. In case of a horizontal crack, it is drilled at both ends and the cracked portion gauged out and welded. In case of vertical cracks, patching strengthens the cracked portion.

**B. Alignment**

The underframe is inspected for its proper alignment and any deflection of its members either in the form of sagging or buckling should be attended to or rectified. Since the alignment of the underframe has a very important role to play in guiding the wheels to run properly, the alignment is to be checked at various planes.

**505. CLEANING AND DE-RUSTING OF THE UNDERFRAME**

The cleaning of the underframe and its fittings can be carried out after the wagon is placed on the trestles. Both the de-rusting and cleaning of underframe and its fittings can be carried out simultaneously. The members of the underframe are de-rusted by scraping and hammering so that it can be checked if any members are by heavily corroded or deformed requiring rectification.

**506. REPAIRS TO HEAD STOCK**

- i. Slightly bent members or portions of them as the case may be, are heated in position by hack's burner and straightened by means of straightening devices or by applying blows with sledge hammer. For carrying out this repair, the buffer assembly is stripped off and if necessary, the floor plate which is riveted to the head stock is gas cut and rivets punched out to facilitate the proper straightening of the bent portion.
- ii. Stripping the heavily bent/damaged members and getting them straightened and aligned in the smith shop.
- iii. All the underframe members are to be inspected as per IRCA Part III (Latest).

**507. REPAIRS TO DIAGONALS AND CROSS BARS**

The repair procedure for these items is also done as per procedure given in para 506.

**508. REPAIRS TO SOLE BARS**

Sole bars are made from ISMC-250x9.0 web channel of copper bearing mild steel for most of the bogie wagons except on BOXNCR wagons where the channel is of IRSM-41 carton steel. Most of the new wagons sole bars are made from CRF sections of IRSM-44 or micro alloyed steel.

Generally, damage to sole bar occurs at locations adjacent to head stock stanchions at door location. The mild steel/IRSM-41 sole bar repaired in the following methods:-

- i. Cutting of entire sole bar portion and grafting a new portion prepared out of channel of the same section. Such type of replacement is always supported with double flanged U shaped sole bar patch, not less than 10 mm thick and a back plate is to be also provided.
- ii. Cracks at flanges and web are given proper repairs by electric welding as per instructions contained in IRCA Part III(Latest) rulebook and issued by authorities from time to time. Cracks extending up to webs are duly support with plain or flanged patch as the case may be.
- iii. Slightly bent sole bars are, however, repaired by local heating and straightening. If the flanges are only bent, the same are straightened by a jawed crow bar.
- iv. The patching has to confirm to IRCA part III rule No. 2.11.3.
- v. No patch shall be less than 10mm thick. Every patch shall be riveted to sole bar web and flange.

- vi. The outer patch shall cover the full depth of the web and the full width of the crack flange, top or bottom.
- vii. The inner patch shall cover the full depth of the channel and shall be of the same length as per the outer patch to the extent possible.
- viii. Where inner and outer patches cannot be fitted due to the presence of other fittings on the sole bar, only the outer or inner patch may be fitted. The thickness of the patch plate in such cases shall not be less than the thickness of parent material.
- ix. The cracks in mild steel sole bar flange may be repaired by welding.
- x. Existing rivet holes shall be utilised for patch rivets.
- xi. Additional rivets shall be of diameter not less than 10 mm at a pitch of not more than 90 mm.
- xii. The length of the sole bar patch plate should not be less than 508 mm.
- xiii. Experience shows that on BG, the underframe of open wagon gets damaged more often than covered wagon because heavier loads are generally carried in open wagons. This also leads to higher incidence of damage during shunting in case of uneven loading or when the consignment is not secured properly inside the wagon.
- xiv. A sketch of a typical straightening device used for repairs of headstock is given at Fig. 5.10.
- xv. Generally pitting/ corrosion on sole bar occur at door ways on open wagons. The provision of protection plates to sole bars is made at these locations, 3.15 mm thick copper bearing mild steel protection sheet is to be welded around the web below the door opening area if the thickness of the web has not been reduced by more than 2 mm whereas by 5 mm copper bearing mild steel plate if the reduction in the web thickness is more than 2 mm but less than 5mm. As the web thickness of the sole bar of ISMC 250 X 82 is 9 mm, it concludes that any sole bar web found to be less than 4 mm should be replaced.

## **509. REPAIRS TO FLOOR PLATE**

The underframe also derives strength from the floor plates, which are generally of 4mm /5mm /6mm thickness. These floor plates are generally riveted/welded to the underframe members, thus providing additional strength to the underframe. As this method is very time consuming, most of the workshops are now resorting to the welding of floor plates as an alternative. This is now an approved practice and RDSO has issued standard sketches for various types of wagons showing how it is to be done.

## **510. UNDERFRAME OF BRAKE VAN**

It has been observed that underframe of brake vans have a tendency to buckle in service.

One method of straightening of the drooping ends is to hold the main members in a fixed position by means of screw couplings anchored against a fixed structure and then raising the ends by means of screw jacks. No heating is required in this case and as such damages to the underframe steel structure which may occur as a result of heating are also avoided.

## 511. BVZI BRAKE VAN

The bogie brake van type BVZI with ICF trolley has been introduced in 2004. The under frame of BVZI brake van is 5 meters longer than 4-wheeled BVZC brake van under frame. Owing to frequent failure in service of CP top bracket of BVZI brake van, the CP top bracket has been modified for new manufacturing vide RDSO letter No. MW/BVZI dated 25.01.2011.

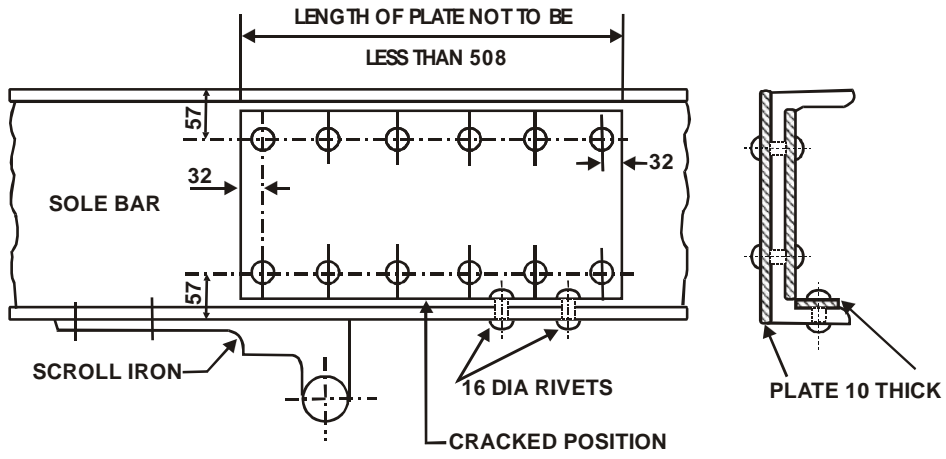
A separate design (Drawing No.WD-11065-S-01) CP top bracket for replacing old design bracket with new unitized design for compulsory replacement during POH/ROH has been issued vide RDSO letter No. MW/BVZI dated 29.12.2011.

Design of foot step of old BVZI wagon was similar to BVZC brake van and during maintenance, bottom foot step was cut by the maintenance depots. Therefore, a separate design for foot step arrangement drawing No. WD-81035-S-19(sheet-2) has been issued for new manufacturing and repair purposes. For guard seat of BVZI wagon, drawing No.WD-04059-S-01 has been issued.

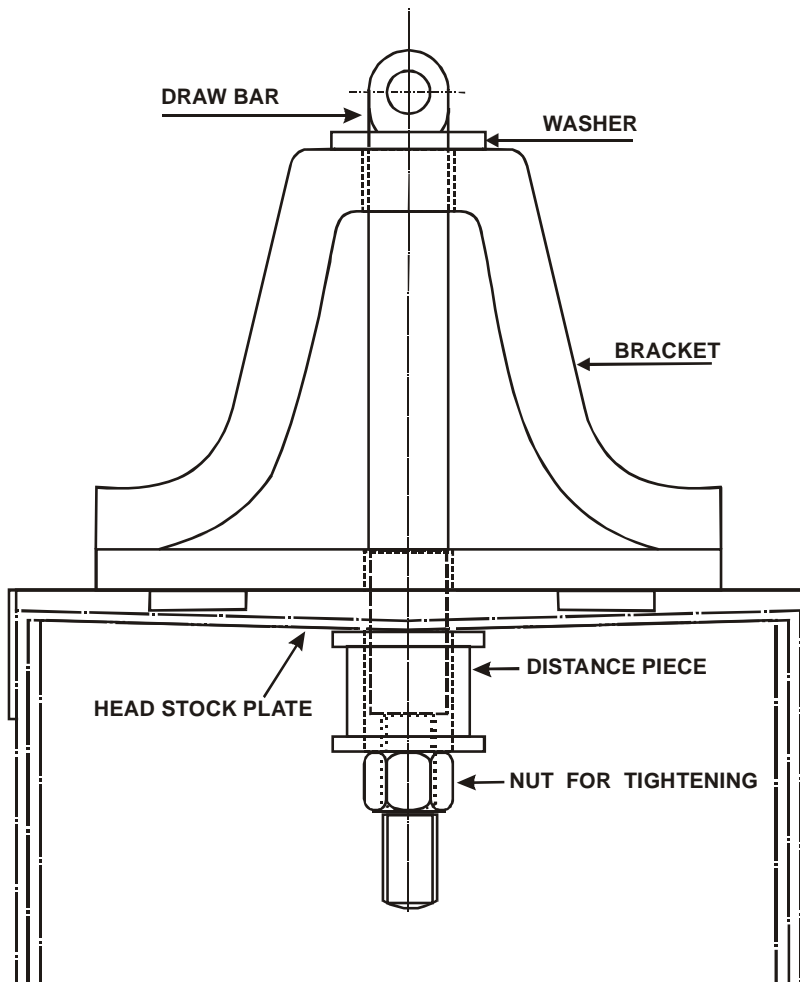
## 512. LIST OF MODIFICATIONS

- i. Provision of side bracket with link on BRN wagons to facilitate securing of steel plant consignments to wagon body vide letter No. MW/ACT/BG dated 27.05.94.
- ii. Provision of stiffener angle on axle guard of BVZC brake van vide letter No. MW/CWSC/SECRETARIAT dated 23.11.93 & 28.2.94.
- iv. Strengthening of BRN wagon underframe vide letter No. MW/BRN dated 7.1.99.
- v. Corrosion in BRN Wagons vide letter No. MW/BRN dated 31.03.1999.
- vi. Modification of CP top bracket of BVZI brake van vide letter No. MW/BVZI dated 25.01.2011.
- vii. Procedure for Re-cambering of Bogie Rail Wagon type "BRN/BRNA/BRNAHS" as given in RDSO's letter No. MW/BRNA dated 03.07.2015.

**NOTE: Repair procedure of stainless steel wagons are discussed in the APPENDIX-VI**



**FIG. 5.9 PATCHING OF SOLE BAR**



**FIG. 5.10 HEAD STOCK STRAIGHTENING DEVICE**

### **513. REPAIR AND MAINTENANCE IN SICKLINE & ROH DEPOT**

Thorough inspection of underframe is to be carried out. Major repairs as well as all defects and deficiencies that come to the notice must be given meticulous and thorough attention. The following work is to be carried out:

- Buffer sub assemblies and draw gear should be within prescribed minimum and maximum dimensions
- Ensure that the buffers are not dead i.e. the springs have not become ineffective otherwise all the buffing load will have to be directly taken by the underframe members leading to extensive damage.
- Head stock, sole bars and diagonal members to be repaired.
- For stocks having chronic failure of the main members, action to be taken to strengthen these members. In order to increase the rigidity of the joints, cast steel/fabricated knees and brackets to be provided.
- All the rivets, specifically of axle guard, scroll irons, head stock and knees joining the main members, are checked for looseness
- In case of a horizontal crack, it is drilled at both ends. The cracked portion is gouged out and welded. In case of vertical cracks, patching is done to strengthen the cracked portion.
- Repairs to head stock to be done as given in para 506.
- Repairs to diagonals and cross bars to be done as given in para 507.
- Repairs to sole bars to be done as given in para 508.

### **514. REPAIR & MAINTENANCE IN WORKSHOP DURING POH/NPOH**

Thorough inspection of underframe is to be carried out. Major repairs as well as all defects and deficiencies that come to the notice must be given meticulous and thorough attention.

In addition to the work indicated in Para 512, the following work is to be carried out in workshops during POH/NPOH :-

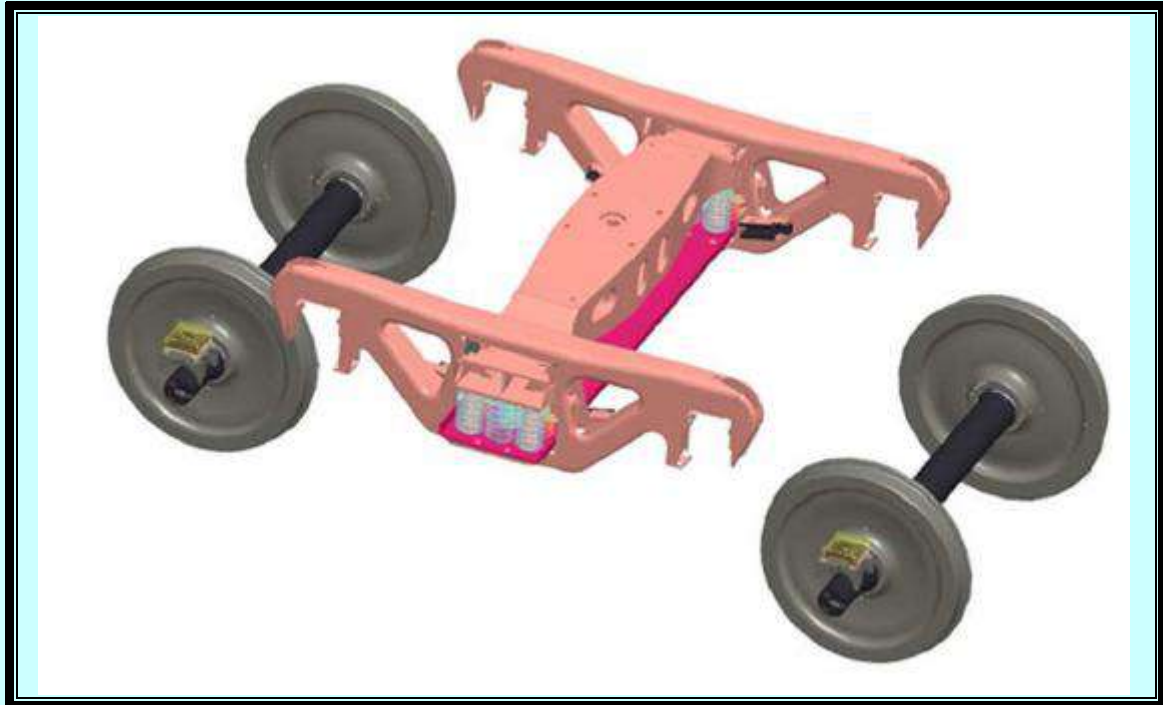
- Inspection of underframe, as given in para 504, to be done for
  - i. Rivets
  - ii. Cracks
  - iii. Alignment
- The cleaning and de-rusting of the underframe and its fittings.
- Repairs to floor plate as given in para 509.
- Underframe of brake van as given in para 510.
- Underframe of Bogie wagon as given in para 503.
- Paint underframe as per Spec. G-72 (Rev.3) or latest amendment.

**XXXXXXXXXX**



*( MAINTENANCE MANUAL FOR WAGONS- 2015 )*

# **CHAPTER - 6**



# **BOGIES AND SUSPENSION**



## CHAPTER 6

### BOGIES AND SUSPENSION

#### 601. CASNUB BOGIE

##### 601A. GENERAL DESCRIPTION

This bogie was first fitted in BOXN wagons and was designated as CASNUB 22W. This was later modified as CASNUB 22W(M) to take care of high wheel wear reported on earlier version. Subsequently CASNUB 22NL (Narrow jaw) and CASNUB 22 NLB (Narrow jaw with fish belly bolster) versions were introduced. The CASNUB 22 HS and CASNUB 22HS (Mod-I) bogies have been developed for high-speed operation with maximum permitted speed up to 100 km/h at 20.32t axle load. All CASNUB 22W bogies were to be converted to CASNUB 22W (Retrofitted) by the maintenance depots and workshops. The various bogie versions developed thereafter, are as under and are now used in the following wagons:-

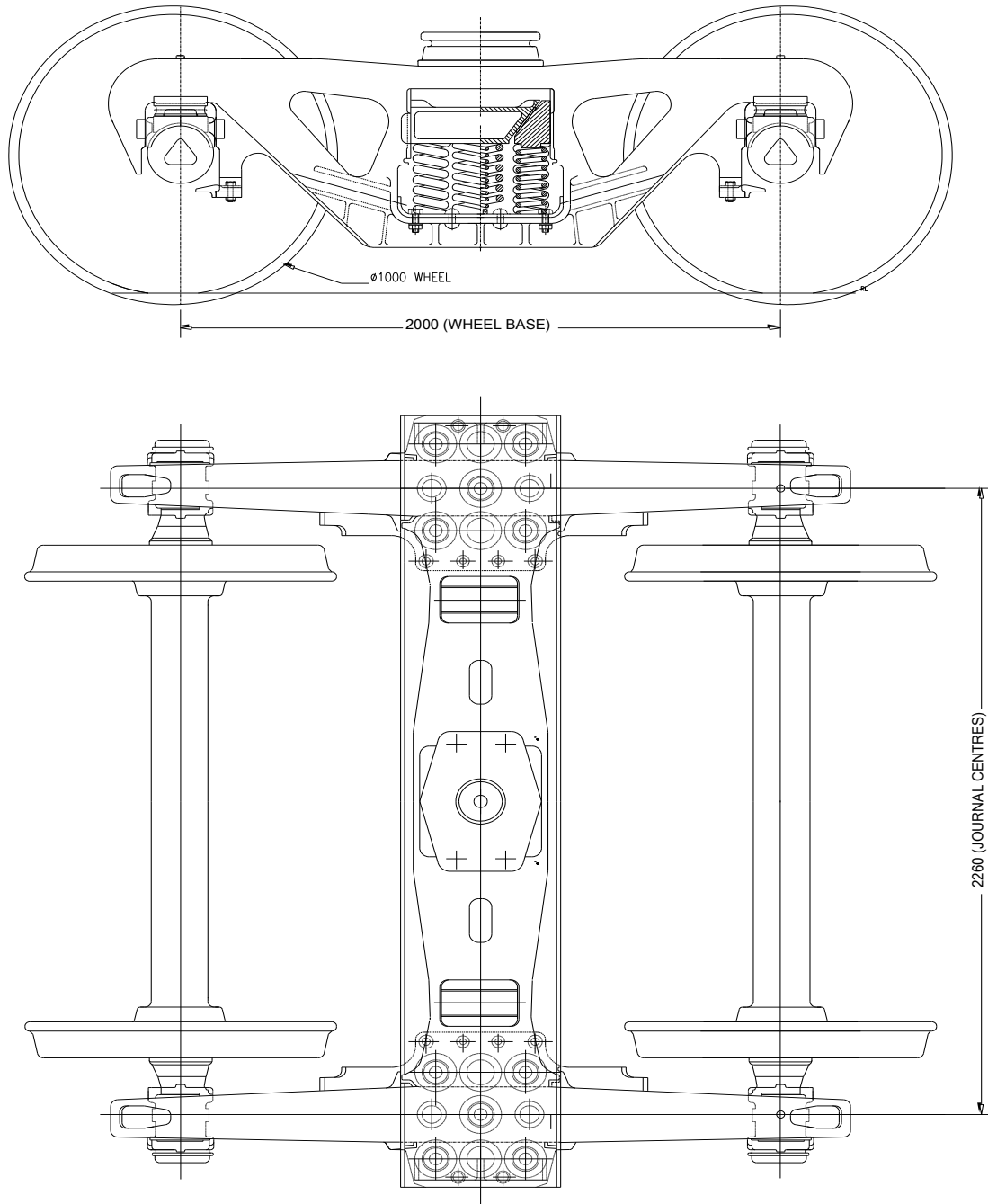
The bogies of type 22W, 22W retrofitted have been phased out considerably hence details of these have not been included in this manual. For details of this type of bogies 2001 version of WMM may be referred.

Bogie	Axle Load	Type of Wagon
CASNUB -22 NLB	20.32t & 22.9t	BOXN, BOXNM1, BCN, BCNM1, BCNA, BCNAM1, BOBR, BOBRM1, BOBRN, BOBRNM1, BRN, BRNA, BTPN, BTAP, BTPGLN, BOBYN, BOBSN, BOY, BCCW, BRSTN, BWTB, BOMN etc and M1 variant.
CASNUB -22HS	20.32t & 22.82t	BOXNHS, BOXNHSM1, BOXNLWM1, BCNHS, BCNHL, BCCW, BCNAHS BOBRNHS, BRNHS, BRN22.9, BRHNEHS, BOSTM1, BOBYN22.9, BOST, BOXNHL BOXNLW, BFNS etc and M1 variant of above.
CASNUB -22HS (Mod-I)	20.32t & 22.32t	BOSTHS, BOSTHS M1,BCBFG
CASNUB -22HS(Mod-II)	22.32 t	BOSTHS M2
CASNUB -22 NLC	25.0 t	BOBRNEL, BOYEL, BOXNEL, BOBSNM1
IRF-108HS	22.82 t	BOXNHAM, BOXNHA, BOXNR, BCCN
LCCF 20(C)	20.32 t 22.0 t	BLLA/B, BLCA/B, BLCAM/BLCBM, BCACM, BCACBM

The wagon list given above is for reference only and is not exhaustive.

**601 B. CONSTRUCTIONAL DETAILS**

The bogie comprises of two cast steel frames and a floating bolster. The bolster is supported on the side frame through two nests of springs. This also provides a friction damping proportional to load. A fabricated mild steel spring plank connects the side frames.



BOGIE GENERAL ARRANGEMENT  
CASNUB 22 NLB BOGIE

**FIG. 6.1 BOGIE GENERAL ARRANGEMENT CASNUB 22 NLB**

*The salient features of components fitted in different types of CASNUB bogies are given below.*

Sr. No	Features	Description
1.	Gauge	1676 mm
2.	Axle load	Modified CASNUB 22HS(Mod-I) -22.32t CASNUB 22HS(Mod-II) -22.32t CASNUB 22NLC -25t IRF 108HS -23.5 t All other bogies- 20.32 t, However these can be upgraded to CC+8t+2t with certain changes in the suspension.
3.	Wheel diameter	1000 mm (New) 906 mm (Condemn) for all except CASNUB 22NLC 955 mm (Min) for CASNUB 22NLC
4.	Wheel base	2000 mm
5.	Type of Axle bearing	Cartridge Tapered Roller Bearing Class 'E' suitable for narrow jaw/ wide jaw adapter
6.	Distance between journal centres	2260 mm
7.	Distance between side bearers	1474 mm
8.	Type of side bearers	RDSO Approved Constant contact type side bearers.
9.	Type of pivot	<b>CASNUB 22W(M), 22NL 22NLB, 22NLM, 22 HS, 22NLC and IRF-108HS -</b> Spherical Type RDSO Drg. No. WD-85079-S/2 <b>CASNUB 22HS, HS(Mod-I), HS(Mod-II)</b> Flat Type RDSO Drg. No. WD-97049-S/3
10.	Anti-rotation features	Anti-rotation lugs have been provided between bogie bolster and side frame
11.	Type of brake beam	<b>All bogies except CASNUB 22W (M):</b> Unit type fabricated brake beam supported and guided in the brake beam pockets. <b>CASNUB 22W (M):</b> Unit Type Cast Steel brake Beam suspended by hangers from side frame brackets.
12.	Suspension details	Long travel helical spring
13.	Elastomeric pads	On all types of bogies.

**The CASNUB bogie assembly consists of the following components:**

- i. Wheel set with Cartridge Bearing
- ii. Axle Box/ adapter, retainer bolt & side frame key assembly
- iii. Side frames with friction plates and brake wear plates
- iv. Bolster with wear liners
- v. Spring plank, fit bolts & rivets
- vi. Load bearing springs and snubber springs
- vii. Friction shoe wedges

- viii. Centre pivot arrangement comprising of Centre pivot top, Centre pivot Bottom, Centre pivot pin, Centre pivot retainer & locking arrangement
- ix. Side Bearers
- x. Elastomeric Pad
- xi. Bogie Brake Gear
- xii. Brake Beam

***The details of above components are as under:-***

**a) WHEEL SET WITH CARTRIDGE TAPERED ROLLER BEARING**

CASNUB bogie are fitted with Class “E” Cartridge Tapered Roller Bearings (CTRB) (6”X11”). Maintenance requirement of cartridge taper roller bearing have been issued under “Instruction for inspection and maintenance of Cartridge Taper Roller Bearing fitted on Cast Steel Bogies”, Technical Pamphlet No. G-81of RDSO. Bearings that have been serviced during POH or otherwise because of re-discing, hot box, accident etc. have to be permanently and legibly marked overhauling particulars on the Cup/Outer ring (on the straight portion in the centre between the raceways) and also on the backing ring as per details/drawing shown in Appendix-IV ‘A’ .However, for detailed maintenance and inspection of CTRB in open line, Handbook on Maintenance of CTRB for freight stock issued under CAMTECH Doc. No. IRCAMTECH/M/12-13/Bearing/1.0, December-20 12 may be referred.

Wheel tread/tyre profile used earlier was standard 1 in 20 taper after the root radius. Currently a worn wheel profile or worn adapted profile has been prescribed to reduce wheel wear and increase wheel life. The tyre/ tread profile for new wheel is as per Drg No. WD-88021. As per requirement, during POH/ROH/Maintenance of wheel set/wheel re-profiling, wheels tread should be turned as per intermediate profile having varying wheel flange thickness selecting the appropriate flange thickness out of the nine flange thicknesses so that minimum material is removed at the time of turning. These intermediate profiles have been incorporated to optimise the wheel life. These are as per Drg. No. WD-89060- S/2.

Wheel diameter for new wheel is 1000 mm. Condemning wheel dia is 906 mm for all versions except **CASNUB 22NLC Bogie**. Minimum wheel dia for **CASNUB 22NLC** bogie is 955 mm.

**b) AXLE**

Axles have to be subjected to ultrasonic testing during ROH/POH or whenever the wagons are sent to the shops. Wheel sets whose axles have undergone ultrasonic testing shall be stamped on the hub fillet as per RDSO’s drawing no. WD-81089-S/1 (**attached at Appendix –IV ‘C’**).

Axle end holes should be properly cleaned and lubricated before reuse. Threads should be checked with standard thread gauge. Reclamation of axles

with defective cap screw holes shall be carried out as per instructions given in RDSO letter MW/WA/Genl dated 8.5.92.

Some axles on CASNUB bogies have been reported to have grazing on account of Main pull rod. This can be reclaimed in case notches/scratch/nicks are less than 5 mm as per instructions issued vide RDSO's letter No. MW/WA/GENL dated 20.12.91. The reclamation of the axle, for reasons not indicated in the above quoted letter, is not permitted.

Whenever axles are renewed, the workshop shall punch the following particulars in 5 mm letters on the axle end:-

- i. Serial No.
- ii. Workshop code where pressing has been done
- iii. Date of pressing
- iv. Pressing on pressure in tonnes (Both ends)

After rediscing, the stamping shall be as per RDSO Drg No. WD-87080/S-1.

**c) ADAPTER OF CTRB, RETAINER BOLT & SIDE FRAME KEY ASSEMBLY**

**CASNUB 22W & CASNUB 22W (M):-**

Wheel sets of these bogies are having Cartridge Tapered Roller Bearing Class 'E' (6" X 11") with Wide Jaw adapter to drg. no. SK 78527. In retrofitted CASNUB 22W bogies, modified wide jaw adapter to drg no. WD – 85053 – S/1 is used.

**All other CASNUB type of bogie except CASNUB 22W, CASNUB 22W (M): –**

Wheel sets are provided with Cartridge Tapered Roller Bearing Class 'E' (6" X 11") with narrow jaw adapter to drg no. WD-89067-S/9.

The wear limits are given in Table 6.1.

**d) SIDE FRAMES WITH FRICTION PLATES**

Side frame column has been provided with 10 mm thickness Silico Manganese Steel wear liners to IS: 3885 Pt.-I Gr. IV welded on the columns. It must be ensured that the liners permitted in service up to a thickness of 6 mm only.

The new friction plate is to be held tight against the column face during welding which should be done in down hand position. Start welding at diagonal ends of the plate and work towards the centre. No paint or grease should be applied on the friction plate.

The side frame should be checked for its wheelbase (distance between centre lines of the jaw openings) and ensure whether the correct button marking is left on the side frame. While pairing the side frame for a bogie, it should be ensured that there should not be any difference between the numbers of buttons on the two-side frames.

The wear limits are given in Table 6.1.

**e) BOLSTER WITH WEAR LINERS**

Bolster pocket has been provided with 8 mm thick silico manganese Steel liners welded with pocket slope. The liners may be permitted in service up to a thickness of 3 mm. The welded liners should be chipped off to prepare the surface for welding new liners. No paint or grease should be applied on the plate.

Some bogie bolsters such as those of CASNUB 22NLB & 22HS bogies have been provided with 5mm thick wear liners on land surfaces & same are to be required to be replaced after 3mm wear.

The wear limits are given in Table 6.1.

**f) SPRING PLANK, FIT BOLTS & RIVETS**

Spring plank is a member made of mild steel (flanging quality) to IS: 5986 Fe 360. It joins two side frames of CASNUB bogie by eight 24 mm dia rivets and four M24 “fit” bolts to keep bogie frame square.

Spring plank should be examined for defects like loosening of rivets/cracks/bending, welding failure of spring spigot etc. Whenever, spring plank is renewed, the leading dimension of the bogie as per Drg no. WD-85054-S/6(22WM), WD-90042-S/1(NL, NLB, NLM, NLC), WD-92058-S/7[HS, HS(Mod-I), HS(Mod-II)] must be measured. Special care is to be taken regarding the use of fit bolts as well as quality of riveting. Fitment of spring plank with side frames should be done on suitable fixture.

**g) LOAD BEARING SPRINGS AND SNUBBER SPRINGS**

The bogies are fitted with two groups of long travel helical spring nests. The spring details are shown in following table-

Type of bogie	Drawing number
CASNUB 22 W(M), NL, NLB, NLM, NLC	WD-83069-S/1
CASNUB 22HS	WD-92058-S/5
CASNUB 22HS(Mod-I)	WD-04017-S/4
CASNUB 22HS(Mod-II)	WD-08026-S/3
IRF 108HS	WD-98014-S/3
LCCF 20(C)	WD-11013-S-01



## DAMPING

The suspension is provided with load proportional friction damping arrangement with the help of manganese steel cast wedge supported on the snubber springs. The springs are manufactured out of silico Manganese steel, chrome vanadium, chrome molybdenum.

The matching of load and snubber springs is important. It is recommended that the springs should be so grouped that the free height variation in the group is not more than 3 mm. Mixing of new and old springs should be avoided. The nominal free height and condemning height are given in Table 6.1.

### h) FRICTION SHOE WEDGES

Friction shoe wedges are fitted on snubber springs. Its vertical surface is with side frame and slope surface is in contact with bolster pocket liners.

A table containing wear limits on vertical surface and slope surface nominal and recommended is placed at Table 6.1.

### i) CENTRE PIVOT ARRANGEMENT

Centre pivot arrangement for various bogies is as follows -

Centre Pivot Arrangement	Drawing No
CASNUB 22W(M),NL,NLB,NLM,NLC, CASNUB 22 HS bogies	WD-85079-S/2
CASNUB 22HS,HS(Mod-I),HS(Mod-II)	WD-97049-S/3
IRF 108HS	WD-98014-S/4
LCCF 20(C)	

**Note:** In CASNUB 22 HS bogies, either a spherical or flat centre pivot can be fitted as applicable.

To determine the seat wear, the gauge should be placed in position. If the pivot surface starts touching the surface marked as ‘\*’ on the gauge at any point, repair to be made by welding. The gauge should be moved on the complete worn surface to be measured. The surface after reclamation shall be the original dimension as per the respective drawings for proper matching of surfaces with top centre pivot.

The repairs should be carried out if a 7 mm thick shim in CASNUB bogie can be inserted for the full depth between the worn surface and the gauge at any point on the vertical wall of the bowl with gauge in position.

During POH/ROH the wear on the vertical side of the bowl, seat of the bowl should be built up by welding. Preheat the surface to be reclaimed up to a

maximum temperature of 250° Celsius. After welding, it should be allowed to cool slowly by covering the welded portion with asbestos/sand.

**j) SIDE BEARER**

CASNUB bogies are fitted with RDSO approved constant contact and PU pad type side bearers riveted/bolted on bolster.

**k) ELASTOMERIC PAD**

Elastomeric pads are provided in all versions of CASNUB bogies. The main purpose of providing elastomeric pad is to reduce wheel flange wear.

Elastomeric pads and metal bonded rubber type constant contact side bearer pads shall be condemned and replaced by new ones on the following grounds :-

- i. If the top of the bottom plates or intermediate plate in case of side bearer pads show any crack in service.
- ii. If any crack of more than 50 mm is developed at any surface of rubber.
- iii. If a bond failure giving way more than 40 mm in any direction is developed in service.
- iv. If any sign of crushing of rubber is noticed.
- v. When in free condition, the pad has taken a permanent set of the order given in Table 6.1/ respective drawing.

**l) BOGIE BRAKE GEAR**

The brake gear mainly consists of Brake Beam (with brake head and brake block assembly), equalising levers, Push rod, End pull rod, Brake Beam hangers (in CASNUB 22W(M) bogies). The pins and bushes provided are as per IS :5517-45C8 hardened/tempered and hardness of pins and bushes to be 250-280 BHN. Material for washer to be IS :2062 Fe410WA. The maximum permissible wear on the pin diameter and bush inside diameter is limited to 1.5 mm.

In service as the tread diameter of wheel decreases due to wear, pins located in End Pull Rod with under frame to be relocated. In case of CASNUB 22W(M) bogies it is of cast steel and Brake head and Block assembly is a separate assembly. This assembly attached with the circular end of a cast steel Brake beam by means of a pin.

In all other bogies the brake beam is fabricated. Brake beam strut and end piece casting are of cast steel. Brake head is integral part of “End Piece Casting”.

**m) BRAKE BEAM [IN ALL BOGIES EXCEPT CASNUB 22W(M)] AND BRAKE WEAR PLATES**

Bogies are fitted with unit type fabricated brake beams that slide in the guide cavity provided in the side frame.

Cavities are provided with silico manganese steel liners. The brake heads are integral part of the brake beam. Brake beam is shown in WD-89033-S/1, however the brake block to WA/BG-6158 is common for all versions.

**CASNUB 22W(M) Bogies**

The bogie is fitted with unit type suspended cast steel brake beam. The brake head is a separate sub assembly which is fixed with brake beam circular end by means of pin passing through brake beam end and brake shoe adjuster along with spring loaded brake head. Assembly provides rotational flexibility to brake head. Details are shown in Drg No. WD-85084-S/1, WD-88012-S/1 & WD-86034-S/1.

**n) RECLAMATION OF BRAKE BEAM ON ACCOUNT OF WORN OUT BRAKE HEADS**

Reclamation procedure for different versions of CASNUB bogie brake beams shall be as follows.

**I) CASNUB 22 W(M) Bogie**

Brake heads are fitted on brake beam with the help of brake shoe adjuster as shown in drawing no. WD-88012-S/1. Brake heads are further secured on brake beam-ends by washer and split pin.

Procedure for replacing worn out brake heads is as under;

- i. Remove split pin and washer from brake beam end. Remove pin securing brake shoe adjuster with brake beam by removing split pin.
- ii. Take brake heads out of brake beam along with brake shoe adjuster.
- iii. Disengage brake shoe adjuster from brake head by providing bolt after disengaging split pin, nut cover, spring and adjusting piece.
- iv. Assemble new brake head with brake shoe adjuster by using items mentioned in para (III) as shown in RDSO Drawing No. WD-88012-S/1.
- v. Slide new brake head assembled with brake shoe adjuster on brake beam end. Engage brake shoe adjuster with brake beam by using pin and split pin as shown in RDSO Drawing No. WD-88012-S/1.

- vi. Further secure brake heads on brake beam end by putting washer and split pin as shown in RDSO Drawing No WD-85054-S/4.

## **II) CASNUB 22 NL, 22NLB, 22NLM, 22NLC, 22HS, 22HS (Mod-I) 22HS (Mod-II) & IRF-108HS Bogies**

Brake head is integrally cast with end piece casting, which is welded with structural steel brake beam channel and Truss flat at ends as shown in RDSO Drawing No WD-89033-S/1. Depending upon the extent of wear, worn out brake heads can either be built up by welding or worn out brake heads can be replaced by new brake head. Replacement of brake head of brake beam should be done on appropriate fixture.

### **601 C. REPAIRS AND MAINTENANCE IN SICK LINE**

In order to obtain optimum life from the bogie, it is desirable to maintain the various clearances within recommended limits. Prescribed clearances are given in para 601 E.

- a. Due to wear of the mating components, increase in clearances should be monitored. Whenever the component reaches the condemning limits, repairs should be undertaken for either building up the wear on such surfaces or changing their liner, as the case may be.
- b. Due to the wear in bolster/side frame liners and wedge surface, the wedges shall move upwards. If the holes of bolster pocket wall and wedges starts crossing, repair shall be under taken. The gauge shall be used for determining the wear.
- c. The class of electrode, gauge of electrode, welding current and welding precautions to be taken while repairing the surfaces by welding.

### **601 D. REPAIR AND MAINTENANCE DURING ROH & POH**

In addition to all the work prescribed at para 601 C above, the following work is also to be done in ROH/POH :-

- a. The bogie should be dismantled during ROH. Dismantling and assembly procedure is given in para e. The bogie clearances and tolerances should be checked and rectified, if found necessary.
- b. Position the job for down hand welding and carry out the repairs. Ensure that suitable manipulators are used.

- c. After the repairs the repaired surface should be checked with relevant gauge for correctness. Excess material, if any, should be removed by grinding or machining.
- d. During POH of wagon in shops, bogies are to be dismantled and all the wearing surfaces of bogie shall be brought to “As New” condition.
- e. Assembly and disassembly of the bogie

#### **I. DISASSEMBLY**

- Remove shackle of centre pivot pin.
- Disconnect bogie end pull rod from under frame and brake pull rod from equalizing lever to raise wagon body. Run out the bogie.
- Inset assembly pin (12mm dia x 250 mm long) to retain friction shoes.
- Raise bolster to touch top of side frame.
- Remove outer, inner and snubber springs.
- Remove assembly pins and lower wedge blocks to take them out.
- Lower bolster to rest on the spring plank.
- Slide the bolster to one side to take it out.
- Take out the S/Frame key from side frame to release the wheel sets, adapter and elastomeric pad.
- Remove the adapter retainer bolt in CASNUB 22W (M) to release the wheel sets adapter and elastomeric pad.
- Take out spring plank from side frame assembly if necessary.

#### **II. ASSEMBLY**

After repair/reclamation and gauging of components with respective gauge, assembly of the bogie shall be done by reversing the procedure of disassembly.

***During assembly of the bogie following points should be taken care -***

- (a) Matching of both load and snubber spring is important. It is recommended that springs having up to 3 mm free height variation should be assembled in same group. Mixing of new and old springs should be avoided.

- (b) Free height of spring / group and wheel dia for bogie assembly should be so selected such that combined drop of centre pivot should not be more than 25mm from that of new bogie. This will help in achieving proper buffer height in loaded condition. Use of 12mm and 35mm packing are also required to be provided as per existing instructions.
- (c) The centre pivot of the bogie shall be lubricated with about 200g – 300g graphite flakes to IS:495 at the time of assembly. No other mating surface in the bogie shall be lubricated.

**Important:** Inspect all the load and snubber springs for proper seating after wagon body is on bogies.

**For detailed description of each item and its maintenance procedure, refer to RDSO publication No. G-95 (Latest Revision).**

#### 601E. NOMINAL CLEARANCES

The nominal clearances and the tolerances of the bogie assembly are given below.

Description	22W 22W (RETRO)	22W(M)	22NL NLB, NLM, NLC	22HS HS(MOD1), HS(MOD2), IRF108HS	LCCF- 20(C)
Lateral clearance between side frame and bolster	18 mm	18 mm	18 mm	25 mm	25 mm
Lateral clearance between side frame and axle box/adopter	25 mm	25 mm	16 mm	16 mm	25 mm
Longitudinal clearance between side frames and axle box/adopter	2 mm	10 mm	9 mm	9 mm	10 mm
Longitudinal clearance between side frame and bolster	6 mm	6 mm	6 mm	6 mm	6 mm
Clearance between anti rotation lug and bolster	4 mm	4 mm	4 mm	4 mm	4 mm

**TABLE 6.1  
WEAR LIMITS FOR BOGIE COMPONENTS**

<b>Sr. No.</b>	<b>Description</b>	<b>New or Renewed</b>	<b>Worn</b>	<b>Wear Limit</b>
1.	<b>AXLE BOX</b> Axle Box Crown lugs (Cylindrical Roller Bearings)	159 mm	167 mm	4 mm
	Axle Box Crown seat (Cylindrical Roller Bearings)	36.5 mm	33 mm	3.5 mm
	Axle Box side lugs (Cylindrical Roller Bearings)	130 mm	136 mm	3 mm
	Axle Box sides (Cylindrical Roller Bearings)	268 mm	262 mm	3 mm
2.	<b>ADAPTER</b> Adapter Crown lugs (Wide Jaw)	156 mm	164 mm	4 mm (One Side)
	Adapter Crown lugs (Narrow Jaw)	155.5 mm	163.5 mm	4 mm (One Side)
	Adapter Crown seat			3.5 mm
	<b>Adapter bore seat to crown seat</b> Wide jaw adapter	48.5 mm	45 mm	3.5 mm
	Modified wide jaw adapter	25.5 mm	22 mm	3.5 mm
	Narrow jaw adapter	26.2 mm	22.7 mm	3.5 mm
	<b>Adapter Side Lugs</b> Wide Jaw	130	136	3
	Narrow Jaw	97	103	3
	<b>Adapter Sides</b> Wide Jaw	268	262	3
	Narrow Jaw	181	175	3
3.	<b>Side Frames</b> Side frame wear friction plate	10	6	4
	Side frame column sides	216	206	10
	Side frame anti rotation lug	522	528	6
4.	<b>Pedestal Crown Roof</b> Key Seat to Pedestal Crown Roof 22W(M)	318	323	5
	Key Seat to Pedestal Crown Roof 22NL/ NLB/HS/IRF 108HS	323	328	5
5.	<b>Pedestal Crown Sides and Sides of the Pedestal</b> All Bogies – Crown Sides	152	144	4
	Pedestal Sides 22W(M)	105	101	2
	Pedestal Sides 22NL,NLB, HS, IRF 108HS	81	77	2

6.	<b>Distance between Outer &amp; Inner Pedestal Jaw of CASNUB Bogies</b>			
	22W(M)	278	286	4
	Pedestal Jaw (Short) for 22NL/NLB/HS, IRF 108HS	190	198	4
	Pedestal Jaw (Long) for 22NL/NLB/HS, IRF 108HS	236	244	4

**\*Adapter of CTRB shall not be welded/reclaimed/renewed at any location**

Description	New	Worn	Wear Limit
<b>BOLSTER</b>			
Pocket	35°/27° +1° on slope		
Liner	8 mm	3 mm	5 mm
Bolster land surface	444 mm	438 mm	3 mm
Rotation stop lug	518 mm	512 mm	3 mm
<b>BOLSTER COLUMN GIBS</b>			
Outer gib	234/241 mm	244/251 mm	5 mm
Inner gib	136 mm	146 mm	
<b>CENTRE PIVOT</b>			
Wear limit vertical side		-	4 mm
<b>SEAT -</b>		-	4 mm
<b>FRICITION SHOE WEDGE BLOCK</b>			
Vertical Surface from Centre line of spigot	61 mm	54 mm	7 mm
Slope surface by gauge	-	-	3 mm

#### **ELASTOMERIC PADS & CONSTANT CONTACT SIDE BEARER**

Type of pad	Free height	Condemning free height
Elastomeric pad	46 $\pm$ 1 mm	42 mm
<b>Constant contact side bearer pad</b>		
<b>A. Metal bonded Rubber pad</b>	114+3-0 mm	109 mm
<b>B. PU side bearer (Three Rings)</b>	142.5 $\pm$ 1.6 mm	137 mm
<b>C. PU side bearer (Two Rings)</b>	134 $\pm$ 1.5 mm	128.5 mm

#### **LOAD SPRINGS**

Bogie Type	SPRINGS	Spring free height nominal (mm)	Recommended free height condemning (mm)
CASNUB 22 W(M), NL, NLB, NLM & NLC	Outer	260	245
	Inner	262	247
	Snubber	294	279
CASNUB 22HS	Outer	260	245
	Inner	243	228
	Snubber	293	278



CASNUB 22HS(Mod-I)	Outer	253	238
	Inner	225	210
	Snubber	304	289
CASNUB 22HS(Mod-II)	Outer	253	238
	Inner	222	207
	Snubber	304	289
IRF-108HS	Outer	264	249
	Inner	246	231
	Snubber	296	281

It is recommended that springs having less than 3 mm free height variation should be assembled in the same group. Mixing of new and old spring must be avoided. The bogie is fitted with two groups of long helical spring nests. The spring groups per bogie for various axle load applications are as under:

Type of Bogie	Axle Load	Number of Springs		
		Outer	Inner	Snubber
CASNUB 22 W(M), NL,NLB, NLM	20.32t	12	8	4
CASNUB 22 W(M), NL,NLB, NLM	CC+8t+2t	14	10	4
CASNUB 22HS	20.32t	14	12	4
CASNUB 22HS	CC+6t+2t and CC+8t+2t	14	14	4
CASNUB 22HS(Mod-I)	20.32t	12	12	4
CASNUB 22HS(Mod-II)	22.32t	12	12	4
CASNUB 22NLC	25t	14	14	4
IRF-108HS	22.82t/23.5t	14	14	4

#### 601 F. REFERENCE DRAWING NUMBERS FOR COMPONENTS

Sr. No.	Components	Drawing No./Pamphlet No.
1.	General Arrangement of Cartridge Tapered Roller Bearing (CTRB)	RDSO Drg. No. WD-92089-S-01 & WD-13042-S-01/G -81
2.	Worn Wheel Profile on wheel tread	WD-88021
3.	Wheel tread Intermediate Profile	WD-89060/S-2
4.	Wide jaw adapter for CASNUB 22 W, CASNUB 22 W(M) & BLC wagon Bogie	RDSO Drg. No. SK-78527
5.	Modified Wide jaw adapter for Retrofitted CASNUB 22 W	Modified wide jaw adapter to RDSO Drg. No. WD-85053-S/1
6.	Narrow jaw adapter for all other CASNUB bogie except CASNUB 22W & CASNUB 22 W(M)	RDSO Drg. No. WD-89067-S/9
7.	CASNUB 22 W(M) wheel set	WA/WL-4902/WD-89025-S/1
8.	All other CASNUB bogie wheel sets	WD-89025-S/1
9.	BLC bogie wheel sets	RDSO Drg. No. CONTR-9404-S/12

10.	Leading dimension and tolerances	WD-85054-S/6(22WM), WD-90042-S/1(NL,NLB,NLM,NLC), WD-92058-S/7(HS), WD-04017-S/7 (HS Mod-I &Mod-II)
11.	Load bearing Springs & Snubber Springs	WD-83069-S/1(All versions except 22HS Bogies) WD-92058-S/5 (22HS ), WD-04017-S/4(HS Mod-I), WD-08026-S/3(HS Mod-II) WD-98014-S/4 (IRF-108HS)
12.	Springs	Silico Manganese steel to IS : 3195 Gr 60 Si7 & Gr 52Cr4Mo2V and RDSO specification WD-01-HLS-94 (rev.3)
13.	Centre pivot other than CASNUB 22W	WD-85079-S/2 & WD-97049-S/3
14.	Elastomeric Pads	WD-95005-S/1 for all
15.	Side Bearers	R.D.S.O. Approved CCSB.
16.	Brake Block	WA/BG-6158
17.	CASNUB 22W(M) bogie, brake beam, brake head & block assembly	WD-85084-S/1, WD-88012-S/1, WD-86034-S/1
18.	Brake beam [Other than CASNUB 22W(M)]	WD-89033-S/1

## 602. FABRICATED BOX BOGIE (UIC BOGIE)

Para has been deleted. If required, Wagon Maintenance Manual ver. 2001 may be referred.

**603.** Para has been deleted. If required, Wagon Maintenance Manual ver. 2001 may be referred.

**604 & 605** Para has been deleted. If required, Wagon Maintenance Manual ver. 2001 may be referred.

## 606. WHEEL ASSEMBLY

### A. Axle

An axle is a steel shaft on which the wagon/rolling stock wheels are mounted. The axle holds the wheels to gauge and transmits the load from the journal bearing to the wheels. Carriage & Wagon axle is made of steel to specification No. IRS-R-16. Its journal portion is suitably designed to mount a bearing. The axle can be divided into following portions:-

- i. Portion between the wheel seats called axle body
- ii. Wheel seat on either side.
- iii. Shoulders just after the wheel seat on either side.
- iv. Journal just after the shoulder on either side.

The portion of the axle on which the wheel is pressed is known as wheel seat. The seat is fine finish machined as per drawing requirements. The shoulder portion is also fine finish machined as per drawing.

Two small axle centres are drilled on end surfaces on the axle. These holes facilitate turning of the axle on centre lathes, grinding/furnishing of the journals and turning of the tyre on the wheel lathe.

Axle on which bearings are mounted should have surface finish and ovality as per drawing. To facilitate the locking of bearing in position, three holes are built and tapped on each face of the axle.

### LIST OF DRGS. FOR AXLE OF DIFFERENT WAGONS

S. No.	Drawing No. Of Finished Axle	Axle Load(T)	Type Of Wagons	Nominal Wheel Seat Dia. In New Finished Condition**	Condemning Wheel Seat Dia. **
1.	WD-89025-S-02	22.9	BOXN, BCN, BRN, BOBR, BTPN, BOY (Fitted with CASNUB 22 NLB/ HS BOGIES)	213 mm	207 mm
2.	WD-89025-S-02	25*	BOXN EL, BOY EL (Fitted With CASNUB 22 NLC Bogies)	213 mm	211 mm
3.	WD-89025-S-02	22	BLC WAGONS	213 mm	207 mm
4.	SK-69601	22.9	BOBY- MARK-II, BOZ, BOXN (with CYL. BRG.)	210 mm	207 mm
5.	WD-92064-S-01	22.9	BWT/A, BWL	210 mm	202 mm

\*Axle to Drg No. WD-89025-S-02 used in BOXN EL/BOY EL etc wagons having CASNUB NLC Bogie up to 25t axle load.

\*\* Refer RDSO's Letter No. MW/WA/GENL dated - 05.03.2003 & MW/25t dated- 08.08.2006 on the subject 'Condemnation of Axles due to wheel seat dia.'.

### B. WHEEL

**The specially designed Cast or Forged steel cylindrical element that rolls on the rail, carries the weight and provides guidance for rail vehicles.**

Only solid wheels are in use on air brake freight stock.

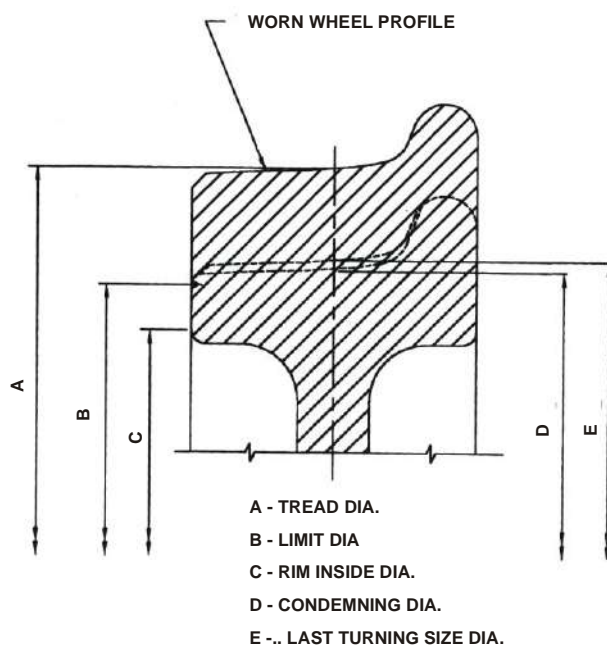
List of drgs. for wheels of different wagons is as under;

**LIST OF DRGS. FOR WHEELS OF DIFFERENT WAGONS**

S.No	DRAWING NO.	AXLE LOAD(t)	TYPE OF WAGONS
1.	W/WL-4764 SK-68512 WD-97037-S-01 OR WAP/SK/M 153	22.9	BOXN, BCN, BRN, BOBR, BTPN, BOY (FITTED WITH CASNUB BOGIES)
2.	*CONTR-9404-S/13 OR WAP/W-004	22.0	BLC WAGONS
3.	SK-69601	22.9	BOBS MK-II, BOZ
4.	W/WL-4771	22.9	BWT/A, BWL
5.	WD-89025-S-05	20.3	BOX, BOX MK-1, BOX MK-II, BVZC

(\*Cast Wheel Disc to RWF Drg. Drg. No. WAP/W-004 is also being used BLC wagons.)

**C. DIAMETERS OF WHEELS USED ON BG STOCK WITH CONDEMNING LIMITS**



**Fig. 6.16 : Wheel profile**

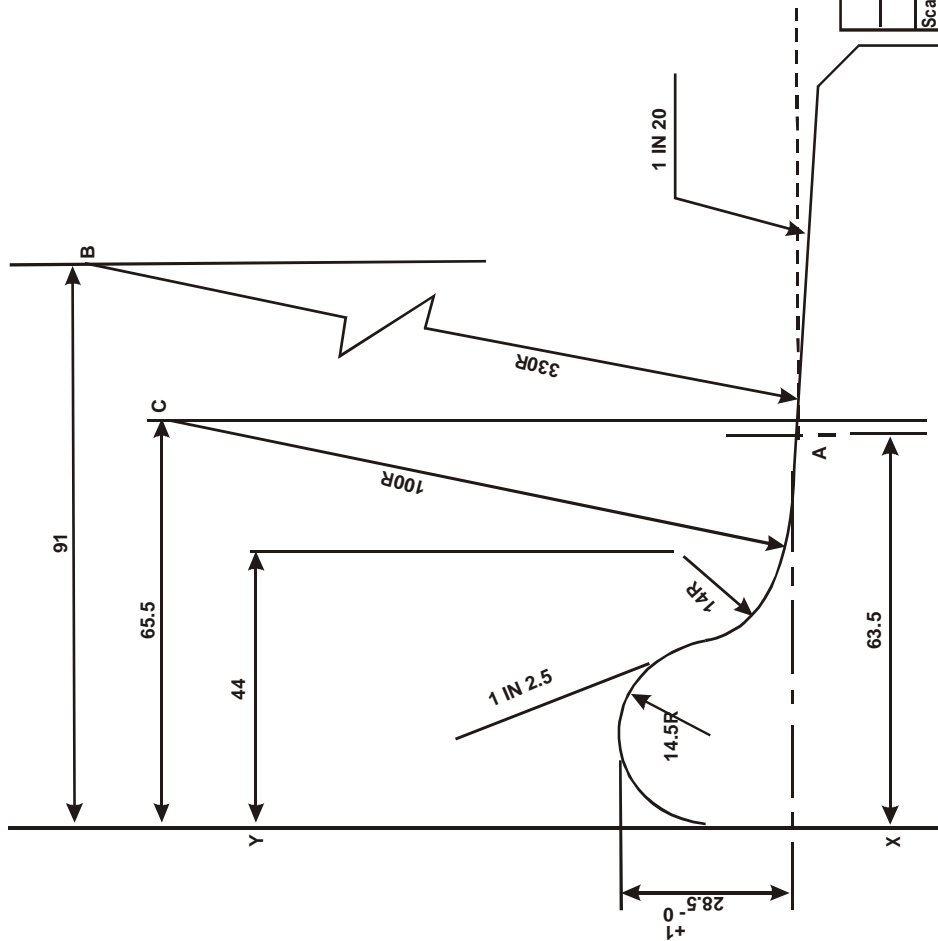
**The last shop issue size and the condemning dia of different wheels shall be as per RDSO Drg.No.WD-88089/S-1 given below;**

S. No.	Axle (t)	Drg. No.	Nom. Dimensions				
			A	B	C	D	E
1.	22.9	W/WL-4764*/SK-68512	1000	897	850	906	919
2.	22.9	WAP/SK/M/153* OR WD-97037-S-01	1000	897	-	906	919
3.	22.9	SK69601	1000	897	850	906	919
4.	22.9	W/WL-4771	915	804	761	813	826
5.	20.3	W/WL-4750	1000	851	814	860	873
6.	20.3	WD-89025/S-5	1000	851	814	860	873
7.	22.0	CONTR-9404-S-13	840	771	730	780	793

\* Minimum service diameter of wheel disc in 25 T axle load having CASNUB 22 NLC bogie like BOXNEL, BOYEL etc. is **955** mm. Last shop issue size of such wheels is 963 mm.

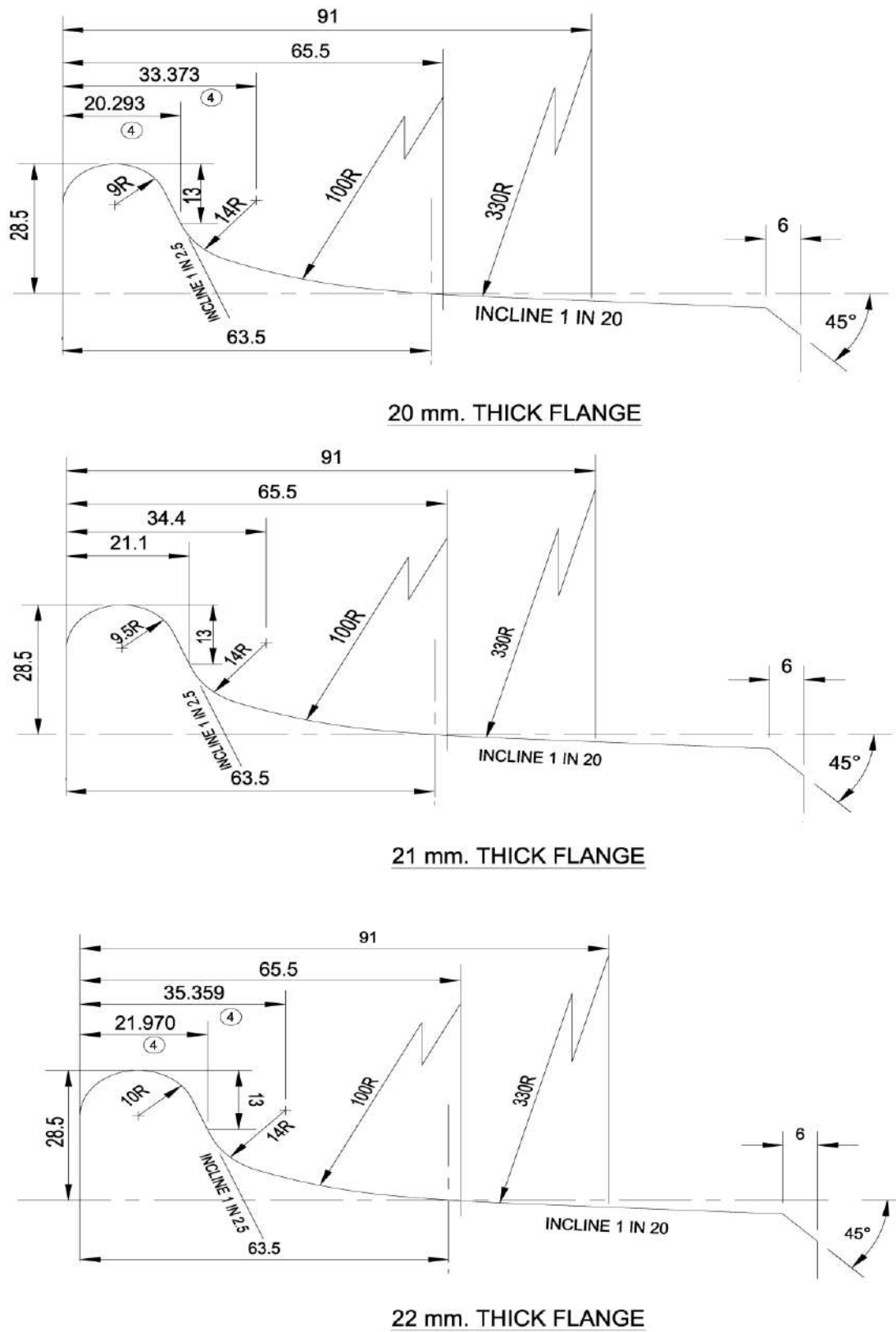
**PROCEDURE OF DRAWING :-**

1. DRAW A VERTICAL LINE X-Y
2. DRAW SEMI-CIRCLE OF 14.5 R TANGENTIAL TO LINE X-Y.
3. DRAW LINE 1:2.5 TANGENTIAL TO 14.5 R SEMI-CIRCLE.
4. DRAW A HORIZONTAL LINE AT 28.5 mm FROM THE TOP OF THE FLANGE AND LOCATE Pt. 'A' AT 63.5 mm FROM THE LINE X-Y.
5. FROM Pt. 'A' LOCATE CENTRE 'B' OF ARC OF 330 R ON A VERTICAL LINE AT 91 mm FROM X-Y.
6. DRAW ARC OF 330 R FROM CENTRE 'B'.
7. LOCATE CENTRE 'C' ON VERTICAL LINE AT A HORIZONTAL DISTANCE OF 65.5 mm FROM THE LINE X-Y SUCH THAT BC=(330-100) i.e. 230 mm.
8. DRAW ARC OF 100 R WITH CENTRE AS 'C'.
9. DRAW ARC OF RADIUS 14 mm TANGENTIAL TO 100 R ARC AND LINE 1:2.5.
10. DRAW LINE 1:20 TANGENTIAL TO 330 R ARC.

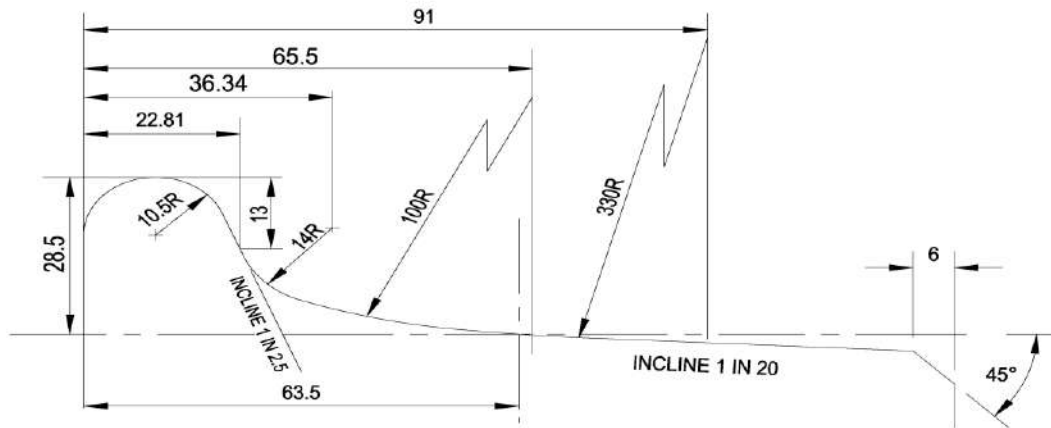


	<b>WORN</b>						
<b>SUPERSEDED BY</b>	<b>BY</b>						
<b>SUPERSEDES Dt.</b>	<b>Dt.</b>						
Scale Passed	Checked	Drawn	Tarcad	J.S. No.	WD-98018	4/98	
<b>B.G.</b>	<b>R.D.S.O. (W)</b>						
<b>WHEEL PROFILE (For B.G. Wagons)</b>	<b>GROUP</b>	<b>WD-88021</b>					
④ ALT.	-	WD-98018	REVISED & REDRAWN	4/98	DATE		
	ITEM	AUTHY	DESCRIPTION	ASSEMBLY DRG.			

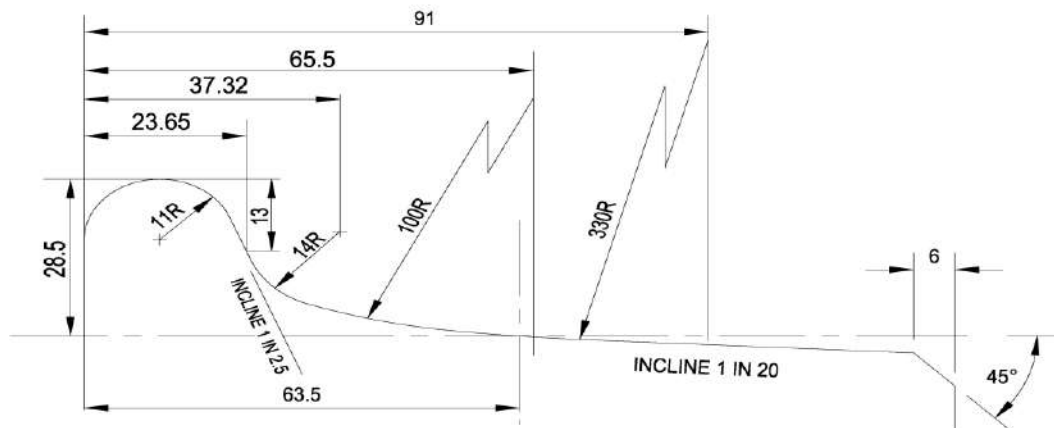
**FIG. No. 6.17 WORN WHEEL PROFILE**



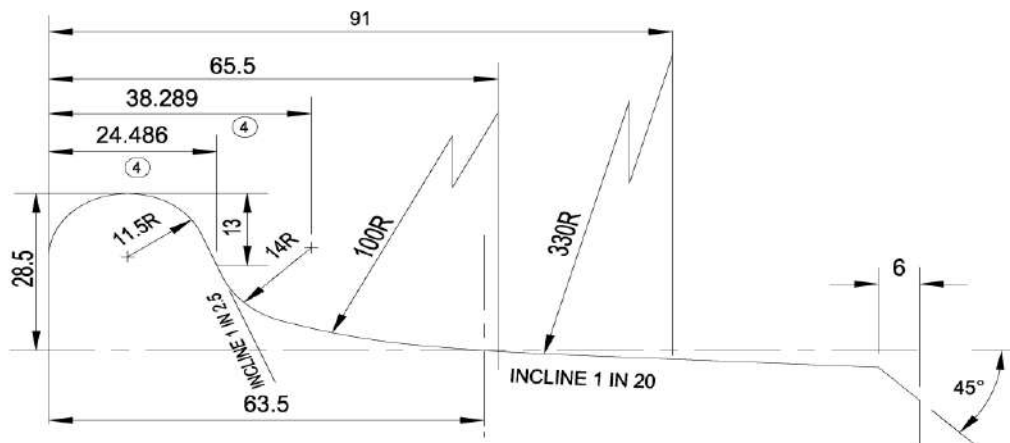
**Fig. 6.18 Intermediate Profile (WD-89060/S-2), Continue.....**



23 mm. THICK FLANGE



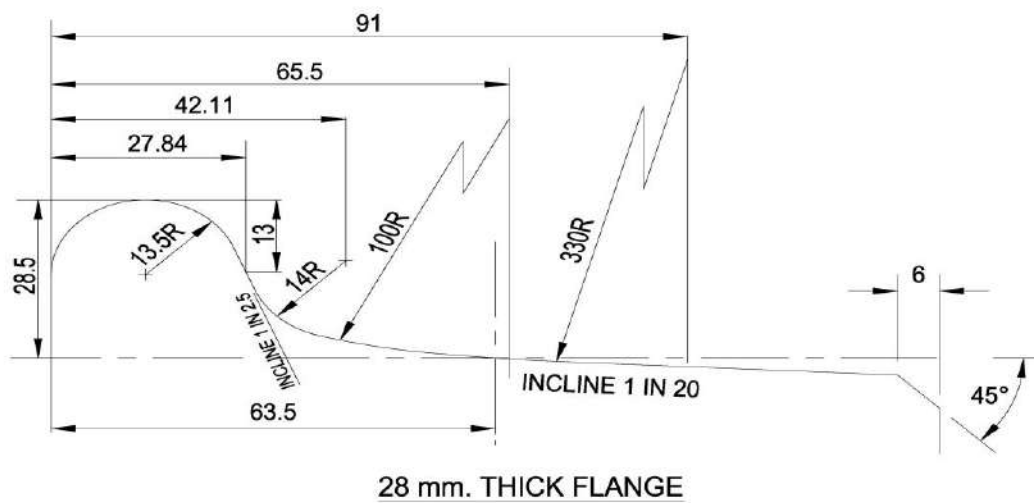
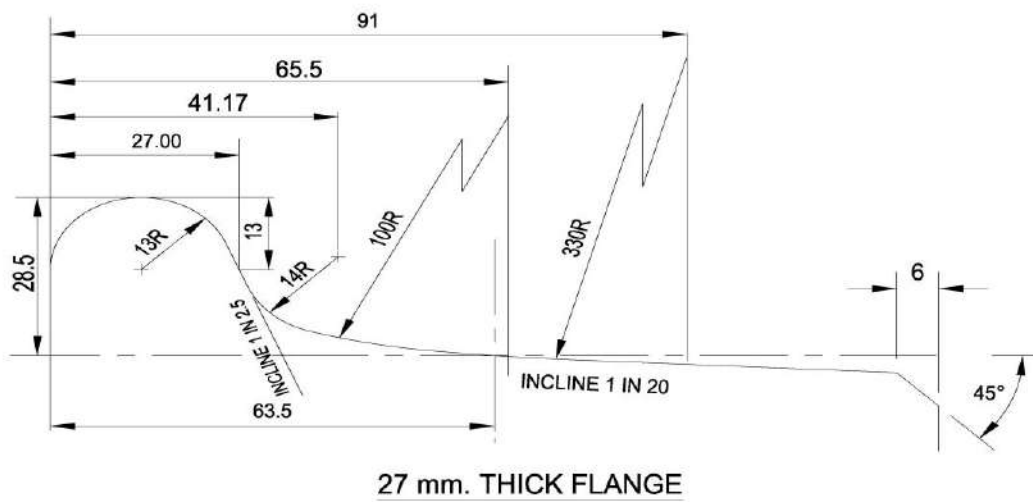
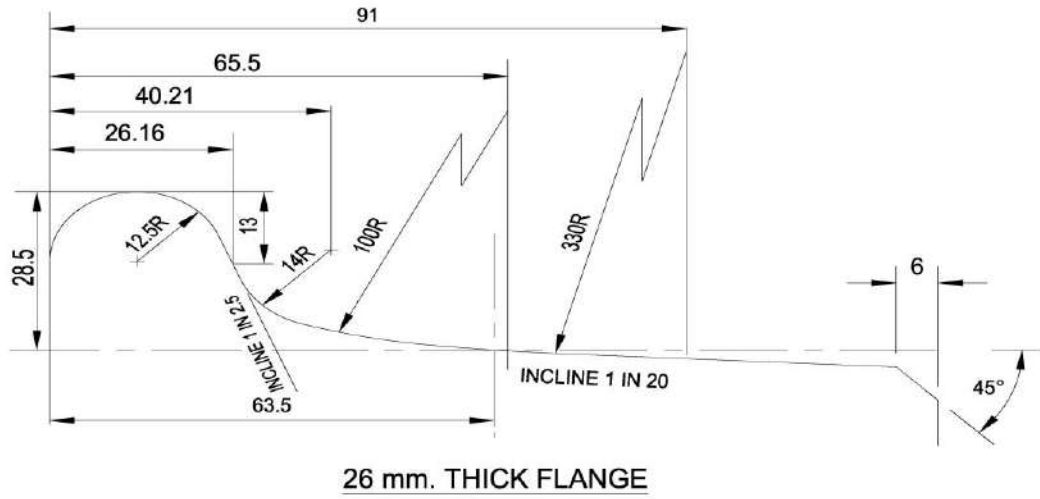
24 mm. THICK FLANGE



25 mm. THICK FLANGE

Fig. 6.18 Intermediate Profile (WD-89060/S-2), Continue.....





**Fig. 6.18 Intermediate Profile (WD-89060/S-2)**

### C. RE-AXLING & REDISCING

Defective axles, which cannot be repaired, otherwise, are required to be replaced. The axles requiring replacement are pressed out of the wheels discs on a Wheel Press specially designed for this purpose. After machining new axles to the required size, wheel discs are pressed on it on the press.

After the wheel discs are pressed out, the bore shall be machined to specified finish as per drawings on a vertical boring machine. The depth of cut should be minimum possible, just enough to remove the irregularity of the surface and to ensure fine finish machined surface. The finish size of the bore should be taken and wheel seat of the axle should be surface finish/roughness machined accordingly to a higher diameter giving allowance for the required interference fit. The selective assembly of Wheels and axle will be done so as to obtain an interference between wheel seat and bore of **1 mm per meter (0.001 mm per mm) dia. of wheel seat** and to ensure assembly pressure build-up of 400 to 600 Kg. per mm. dia. of wheel seat. During assembling process/assembly of wheel and axle shall satisfy Para -2, 3, 5 & 7 of IRS specification R-19/93 Part I.

While pressing the wheel, care should be exercised to see that the pressing is stopped at a pre-marked correct location on the inner side of the wheel seat.

#### *At the time of re-axling, following points to be ensured:-*

- i. Before mounting the wheels on axles, carefully clean the wheel seat and bore of the wheel to remove rust grit, chips and grease.
- ii. Coat wheel seat and bore with mixture of basic carbonate white lead and boiled (not raw) linseed oil to avoid scoring of mounting surface.
- iii. Keep special care so that wheel-seat and bore and not damaged during mounting operation.
- iv. Mounting press must have dial pressure gauge and a pressure recording gauge.
- v. Mount the wheels centrally on axle at a proper gauge distance.
- vi. Recorder must be maintained and kept properly adjusted all the time.
- vii. Check wheel mounting and check gauge frequently so that excessive wear does not allow improper mounting of wheels.
- viii. Stamp at the front Hub edge for the rediscing particulars as per RDSO Drg. No. WD-87080/S-1 to facilitate tracing of history of the wheels.
- ix. After mounting of wheels on axle apply rail gauge at three or more equidistant points around the circumference to see that wheels are within gauge limits.

### D. TYRE TURNING OR REPROFILING

To remove irregular surface on the profile caused due to wear in service re-profiling is to be done. In service some of the wheels develop defects beyond the permissible limit for the safe turning. Such wheels are to be withdrawn and should be sent to workshop for removing the defects. The wheel requiring re-profiling shall be

turned to worn wheel profile or to intermediate profile to RDSO Drg. No. WD-88021 or WD –89060/S-2 respectively.

On receipt of wheels in wheel shop, the diameter of both the discs at wheel tread should be measured. Some times wheel with unequal dia. on the same axle are received. Many times skidded wheels are received due to which tyre surface at some spots gets hard. Such spots can not be machined on wheel lathes available in many workshops. Such wheels should be sent to re-profiling section for softening the hard spots on suitable designed furnaces. After softening, the wheels should be sent to tyre turning section.

Tyre turning is done on a specially designed wheel lathe. The root radius, vertical inclined surface, radius on the top of the flange are difficult portions to be machined. To machine these portions, specially designed gadgets are provided on the Tool ports.

***While tyre-turning, the following should be kept in mind:-***

- i. The wheel gauge, i.e. the distance between the flanges of the 2 wheels of the same axle should be within the laid down limit. The aspect has to be particularly ensured when new tyres have been fitted. On old tyres normally the distance is correct. But in some cases where the machining has not been done accurately in the past, the distance may be beyond the permissible limit. If the distance is less it can be corrected by machining the side surface of the wheel. In case the distance is more, the wheel shall required re-axling. It is very important that the turner of the wheel lathe checks this distance at the time of turning in addition to the check done by incoming Inspection staff. The laid down distance is 1600 +2/-1 mm for BG.
- ii. The variation in tread diameter of wheel tread/ tyres on the same axle after fresh turning on surface wheel lathe/ under floor wheel lathe/pit wheel lathe should not exceed 0.5 mm. The turner normally machines the wheels to equal diameters. However, small variation may occur if the cut has not been taken carefully. After finishing the operators should assure dia of both wheels. If the difference is more than 0.5 mm he should take another cut on the tyre having the large diameter.

**E. PAIRING OF WHEELS**

Different wheels fitted on a wagon are to be paired. Normally it is done in the Lifting section of the wagon shop. Where large number of wheels of the same type are turned on each day, no difficulty is experienced for such pairing. However, when the supply of wheels to Lifting section is from hand to mouth such pairing for the day's requirement has to be done in the tyre, turning section of the Wheel shop itself. Pairing in Wheel shop also becomes necessary for special tyre of wheels received in small numbers. When pairing is done in the Wheel shop, it becomes necessary to turn such wheels even to lesser diameters than is required from the point of view of wear. For such cases specific instructions should be given to turner of the Wheel lathe. The variation in tread diameter should be as per Clause 2.8.14.2 of IRCA Part III.

**F. WHEEL DEFECTS**

*The wheels are required to be withdrawn from service for the following major defects:-*

- i) Reached condemning limits
- ii) Flat places/skidded
- iii) Flanges sharp/deep/thin
- iv) Too insufficient radius at the root of flange
- v) Gauge slack/tight
- vi) Cracked or broken

Defects i) to iv) mentioned above are detected with the help of tyre Defect Gauge. Defect as in item (v) is checked by Wheel Gauge. Defect as in item (vii) is determined by visual examination.

**Permissible maximum flat surfaces on tread are as under:**

Wagon Type	Permissible Flat Surface
BG Wagons	60 mm

**a) THIN AND SHARP FLANGE**

- (i) For proper method of using Tyre Defect Gauge, please refer IRCA Part III .
- (ii) Wheel may be passed provided the minimum thickness of flange is 16 mm.
- (iii) Wheel must not be allowed to run if flanges are worn to knife edge but may be passed if the radius is not less than 5 mm.
- (iv) Wheels with too small radius at the root of flange should not be allowed to remain in service.

**607. GREASE FOR CTRBs**

Grease to RDSO<sup>s</sup> Specification No. WD-24- MISC-2003 is to be used in CTRB. Before applying the grease, clean all the equipment to be used for lubrication. Apply grease to each single assembly and between the roller and cage assemblies in the quantity as given below:

**Amount of grease to be applied**

To Single Roller Assembly (Each Cone Assembly)	Between Roller Assembly (Around spacer)	Total $\pm^{30}$ gm
115 gm	170 gm	400 gm

## 608. MAINTENANCE AND REPAIR OF CARTRIDGE TAPERED ROLLER BEARINGS

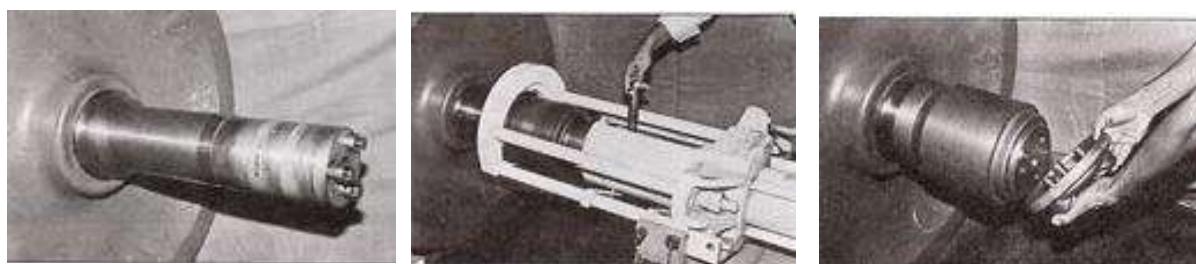
The following are the recommended practices for long life and trouble-free operation of Cartridge Tapered Roller bearings:

### (a) Recommended Practices for Railway Workshops:

- i) Cleaning, inspection and assembly of cup & cones to be done in controlled environment to avoid ingress of dust particles.
- ii) 100 % checking of groove depth of seal wear ring and re-use of only correct wear ring or replace with new one. Use of seal wear rings with vent holes needs to be stopped immediately. Use of proper measuring instrument is required for seal wear ring groove depth.



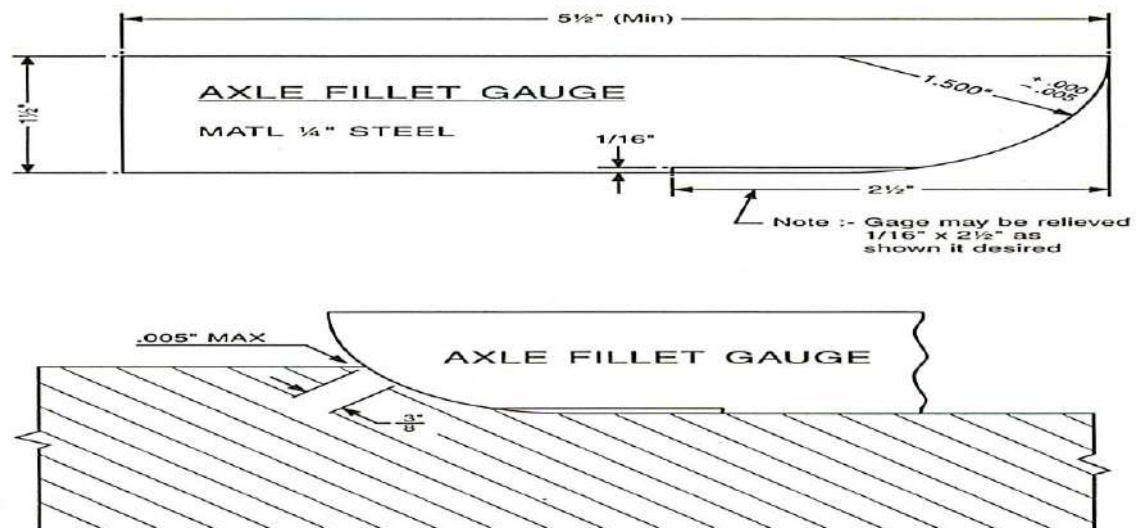
- iii) Bearing mounting machine needs to be periodically calibrated for its proper working at specified force (50 +/- 5 Tons) with ensuring holding for specified time (5 seconds). Use of the proper fixture (tooling) needs to be ensured. The pressure – force conversion configuration for the specified machine may be prominently displayed near the mounting area for the benefit of the mounting staff.



- iv) Checking of journal diameter at three locations with snap gauges may be enforced for ensuring specified fits to obtain the desired mounting force.



- v) Checking of fillet radius after proper cleaning for correct seating/ fitment of backing ring may be ensured. Backing rings with vent holes should not be reused. They should be replaced with plugged backing rings or new backing rings



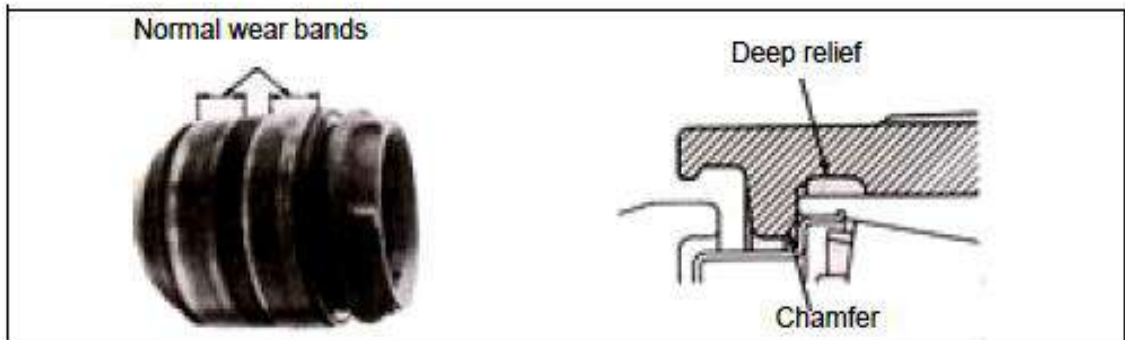
- vi) Proper tightening of end cap screws with periodically (monthly) calibrated torque wrench at specified torque may be ensured on wheel sets. The specified torque should be maintained to 40 Kg – m (290 foot-pound). The torque wrench must be maintained with an accuracy of +/- 4% (Maximum). Minimum 2 passes and maximum 5 passes to be applied to ensure proper clamping. If any screw movement persists after 5 passes check for any irregularity.



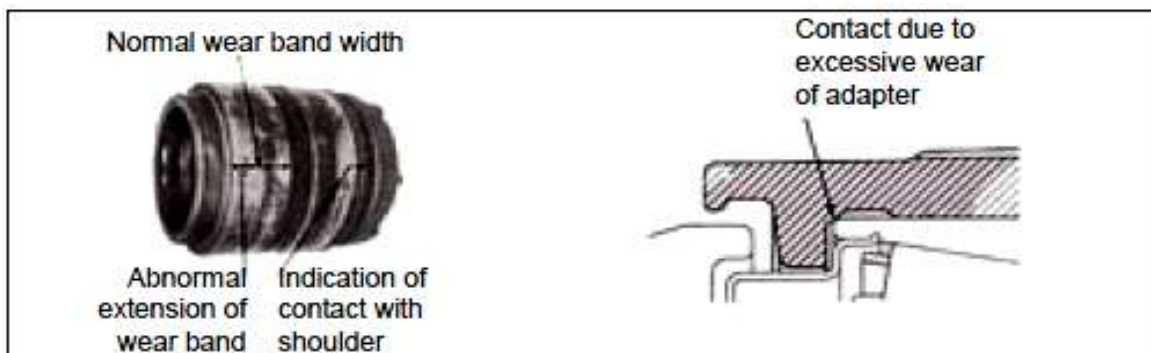
- vii) Axle threads to be checked with Go- No Go gauge and Axle thread holes should be cleaned by compressed air.
- viii) Inside surface of Adapter is required to be checked for wear on thrust shoulder and bearing seating area/adapter machined relief with proper gauges (Sample gauge is depicted below). Gauging as per G 95 may be ensured.



- ix) Assembly of bogie using properly checked adapter may be ensured. Railway workshops must manufacture/procure specified gauges for this checking. Cups should be checked for wear patterns seen on the cup outside diameter as it reveals excessive wear of the adapter. The figure below shows normal wear bands present on cup OD generated from a serviceable adapter.



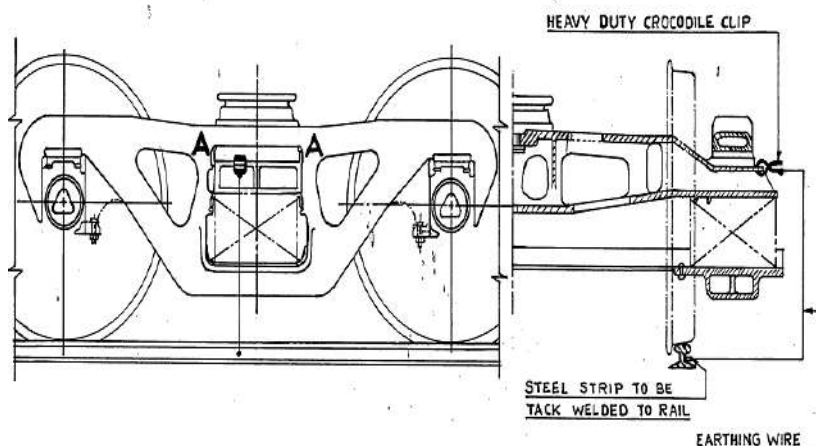
Wear bands formed due to excessively worn out adapter are illustrated below. In case of fully worn out adapter, the cup starts contacting the adapter at the ends also. Worn out adapters must be scrapped. Displaced adapters also form two distinguished marks on the cup outside diameters. And such cups must be examined for spalls being generated on raceways under the adapter contact areas.



- x) Checking of the mounted end lateral play may be ensured on each mounted CTRB. This is critical to bearing performance. With correct mounted lateral more roller share the load. As a result, peak load on individual rollers are less. Excessive mounted lateral causes high peak roller loads. As a result of fewer rollers sharing the load. This reduces fatigue life.



- xi) Welding on the wagon after lowering of bogie shall be avoided as far as possible. If any welding work is done after assembly of wagon proper earthing shall be ensured (specifically in odd hours) so that electric current does not pass through the bearings. The earthing should be done very close to welding area and the earthing wire should be tightly secured at both ends. Alternatively the earthing can be done with an earthing wire/strip running parallel to the track instead of earthing with the rails. If wagon is not properly earthed the current passing through the bearings will cause arcing in between the rollers and the raceways leading to failure. All the earthing ports may be properly grounded through periodically calibrated earth pits. One of the recommended scheme of earthing is shown below:



- xii) Separate investigation of defective CTRBs coming from divisions may be done.
- xiii) The fitment of cup and cones of same make in overhauled CTRBs may be ensured. To the extent possible they may be maintained with similar age profile.



- xiv) The stamping of overhauling date & workshop code may be done on backing ring of CTRB also as per RDSO letter no. MW/WA/Genl dated 26/04/2012.
- xv) Handling of wheel sets with proper lifting tackles shall be ensured. Use of wire slings for lifting of wheel sets may be avoided. Similarly, securing wire ropes near bearing area while pulling the wagon may also be avoided.

Periodic audits of CTRB fitment/maintenance including wheel handling to be done using check sheets already circulated vide RDSO letter no. MW.CTRB.D dated 23/12/2010.

**(b) Recommended Practices for ROH Depots:**

1. Area where bearings are opened for UST of axle must have controlled environment.
2. Proper visual examination of bearings to be done. Some important aspects to be checked are as under:
  - 2.1 Overheating, such as discoloration or parts fused together.



- 2.2 Check for loose and/or missing cap screws.



- 2.3 Check that all tabs of the locking plate are properly bent up against the flats of the cap screw heads in the loosening direction.



2.4 Inspect for damage or wear to the end cap from a displaced adapter.



2.5 Examine the bearing for welding damage or exposure to extreme heat, such as from a cutting torch. Remove the bearing from service if you find any damage.



2.6 Check for cracked or broken outer rings (also called bearing cups).



- 2.7 Inspect for a loose backing ring. If you can move or rotate the backing ring by hand, remove the bearing from service.



- 2.8 Check the backing ring for damage or wear from a displaced adapter.



- 2.9 Check whether the grease seal is displaced or cocked or has external damage.



3. While carrying out wheel turning, the prescribed dummy/protective covers (as mentioned in clause 6.22 & shown in Drawing No. WDIIA-8514/S-1, included in Annexure of G-81) on bearing may be used.
4. Proper tightening of end cap screws with periodically (monthly) calibrated torque wrench at specified torque may be ensured on wheel sets. The specified torque should be maintained to 40 Kg – m (290 foot-pound). The torque wrench must be maintained with an accuracy of +/- 4% (Maximum). Minimum 2 passes and maximum 5 passes to be applied to ensure proper clamping. If any screw movement persists after 5 passes check for any irregularity.

5. Handling of wheel sets to be done by using the prescribed lifting tackle and not wire ropes which can damage the grease seals.
6. In case bogie(s) are dismantled for any purpose, the adapter must be thoroughly inspected for soundness and wear. Gauging must be done as specified in G 95.
7. Ensure the Adapter is properly placed on CTRB. Most bearings will “creep” in service, creating two wear bands as pictured below. This is a normal condition that also causes wear to the adapter’s seat pads



Wear bands that extend to the end of the outer ring, as shown on the left side of the image below, indicate an excessively worn adapter seat. A shiny edge at the extreme end of the outer ring, as shown on the right side of the image below, is an indication that the thrust shoulder is worn. Replace the adapter if either of these conditions exist.



8. Whenever wagons or bogies fitted with CTRBs require welding in ROH Depots/Sicklines, special attention should be paid so that electric current does not pass through the bearings. The earthing should be done very close to welding area and the earthing wire should be tightly secured at both ends. Alternatively the earthing can be done with a earthing wire/strip running parallel to the track instead of earthing with the rails. If wagon is not properly earthed the current passing through the bearings will cause arcing in between the rollers and the raceways leading to failure.
9. The stamping of overhauling date on backing ring of CTRB has been advised to be done by workshops on each overhauled bearing to ensure traceability. In case CTRBs fitted wheel are found to be overdue overhauling in course of ROH/Sick line examination to the wagon, such wheels must be sent to nominated workshop for overhauling.

**(c) Recommended practices during incoming train examinations in yards**

1. Detection of warm bearings on arrival of the train. Check operating temperature of the bearing by touching the adapter or underside of the bearing cup with bare hands immediately after the vehicle is halted. If it is found impossible to hold the hand for a few seconds on the adapter or the cup it means that the bearing is running hot. Cross check the bearing temperature with temperature sensing hand held pyrometers/sensors giving direct reading of the bearing. If bearing temperature is more than 90 degree centigrade the wagon should be detached and bearings should be removed from the service.
2. Check for any abnormal sound and/or grinding noise.
3. Visually inspect the bearing for defects like broken cup, loose or damaged grease seals, broken adapters, missing cap screws, broken /distorted end cap, broken locking plate. Check for loose backing rings, missing side frame key. Any of these conditions are reasons for bearing removal.
4. Checking of displaced adapters [as mentioned in clause 6.1.1(d) of G-81].
5. Availability of adapter retaining nut & bolt in wide jaw bogies.

**(d) Axle Box Feeling of Freight Trains*****The procedure of axle box feeling is as under:***

1. Axle box feeling should be done immediately after the arrival of the train and two technicians, one from the left and another from the right side should do the job.
2. Axle Box feeling must be done on the adapter or the underside of the CTRB cup.
3. Hand held pyrometers should be used for detecting the temperatures; in addition the practice of feeling the boxes with back side of palms should be followed. Such pyrometers should be calibrated regularly. The wagons with axle boxes having temperature more than 90 Degree Celsius should be detached.
4. The axle boxes having grease oozing, burning smell, missing/lose end cap bolts, loose backing rings, grease seals and burnt EM pads are the indicators of potential hot box cases.

The above instructions should be displayed at the axle box feeling points for the guidance of the technicians.

(RDSO Letter No. MW.RB.Genl Dated 20/21.11.2012)

**609. Arrangement of springs in various CASNUB trolleys according to axle load**

Type of wagon	Type of trolley	Spring nest arrangement for 20.32 t axle load	Modified Spring nest arrangement for 22.9 t axle load (M1)	Spring nest arrangement for 25t axle load (with NLB trolley only) EL / (BOBSNM1)
BOXN BOXNR BOXNCR BCN BCNA BOBRN BOBSN BOY BOBYN	22W, W(M), NL, NLM, NLB,			
BOXNHS BOXNLW BOXNHL BOST BCNAHS BCNHL	22HS			NA
BOSTHS	22HS (Mod-1)			NA
BOXNHA	IRF108HS			NA
BRN BRNA BTPN BTPGLN	22NLB		NA	NA

BRNAHS BFNS BRHNEHS	22HS		NA	NA
BLCA/BLCB	LCCF20		NA	NA

\*NA= Not applicable

**(a) Nomenclature of Bogie:**

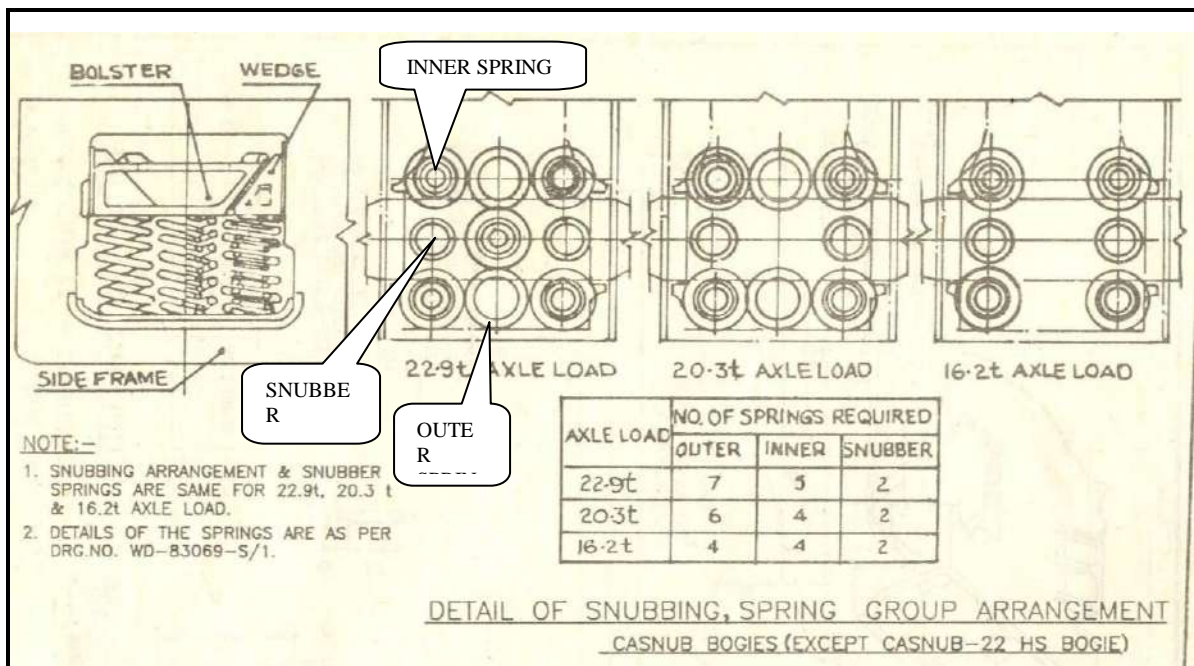
<b>W</b>	<b>M</b>	<b>N</b>	<b>L</b>	<b>B</b>	<b>HS</b>
Wide Jaw	Modified	Narrow Jaw	Light weight	Belly shaped bolster	High Speed

**Load Bearing springs and snubber springs:**

CASNUB bogies are fitted with two groups of long travel helical springs nests. The spring group for bogie for various axle load application are shown in fig below.

Spring details are shown in WD 89069-S/1 (Common for all versions except Casnub - 22HS Bogie). The spring details for Casnub - 22 HS bogies are shown in WD - 92058-S/5.

**Damping:** The suspension is provided with load proportional friction damping arrangement with the help of Mn steel Cast Wedge supported on the snubber springs. The details of the snubbing arrangement are shown in fig below.

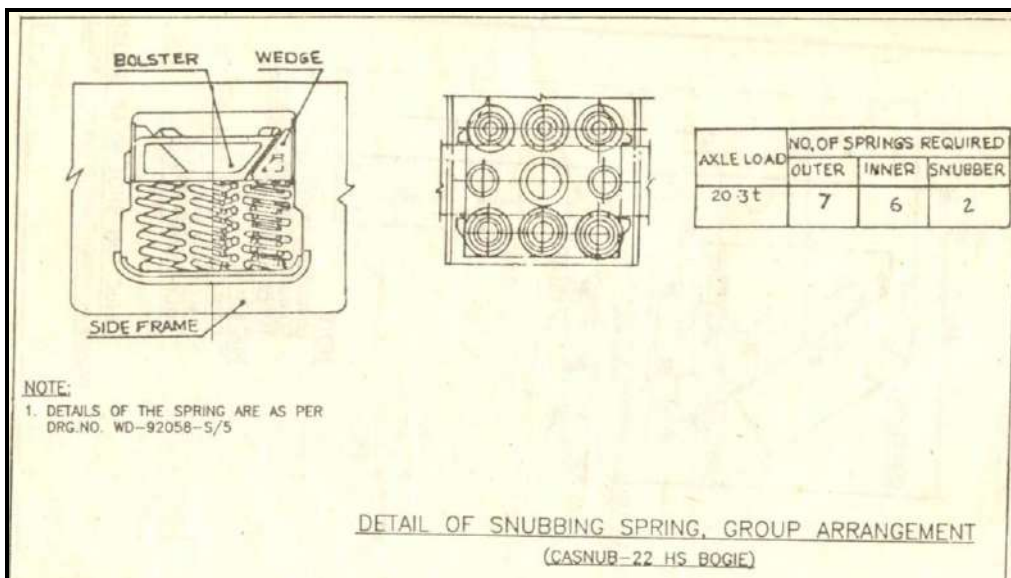




Spring nest



spring gauging



**(b) Grouping of Springs: (By strip method)**

**A. Group Band (Coloured) for in service springs (Maintenance group)**

Matching of both, load and snubber springs, is important. It is recommended that springs having **not more than 3 mm free height variation** should be assembled in the same group. Coloured band should be provided for easy identification of group height as indicated in the table.

All versions (except for CASNUB 22 HS)

No. of Bands	Outer	Inner	Snubber
I	260-257	262-259	294-291
II	257-254	259-256	291-288
III	254-251	256-253	288-285
IIII	251-248	253-250	285-282
Red	248-245	250-247	282-279

**CASNUB 22 HS**

Group	Outer	Inner	Snubber
I	260-257	243-240	293-290
II	257-254	240-237	290-287



<b>III</b>	254-251	237-234	287-284
<b>IIII</b>	251-248	234-231	284-281
<b>Red</b>	248-245	231-228	281-278

**CASNUB 22 HS (Mod-1)**

<b>Group</b>	<b>Outer</b>	<b>Inner</b>	<b>Snubber</b>
<b>I</b>	253-250	225-222	304-301
<b>II</b>	250-247	222-219	301-298
<b>III</b>	247-244	219-216	298-295
<b>IIII</b>	244-241	216-213	295-292
<b>Red</b>	241-238	213-210	292-289

**B. Group Band (Coloured) of NEW Springs,**

Matching of both, load and Snubber springs, is important. It is recommended that springs having less than 3 mm free height variation should be assembled in the same group.

**All versions (except for CASNUB-22 HS)**

Ref: DRG No.WD-83069-S/1

<b>No. of Bands</b>	<b>Outer</b>	<b>Inner</b>	<b>Snubber</b>
<b>I</b>	263-261	265-263	297-295
<b>II</b>	261-259	263-261	295-293
<b>III</b>	259-257	261-259	293-291

**CASNUB- 22 HS,**

Ref: DRG. No.WD-92058-S-5

<b>Group</b>	<b>Outer</b>	<b>Inner</b>	<b>Snubber</b>
<b>I</b>	263-261	243-241	293-291
<b>II</b>	261-259	241-239	291-289
<b>III</b>	259-257	239-237	289-287

**CASNUB -22HS (Mod-1) BOSTHS,**

Ref: DRG No. WD-04017-S/4

<b>Group</b>	<b>Outer</b>	<b>Inner</b>	<b>Snubber</b>
<b>I</b>	256-254	228-226	307-305
<b>II</b>	254-252	226-224	305-303
<b>III</b>	252-250	224-222	303-301

\*\* Mixing of new and old springs should be avoided.

**(c) SPRING DATA:**

Type of spring	Coil Dia. in (mm)	Free height (in mm)	Condemning limit( In mm)
<b>All visions (except for CASNUB-22HS)</b>			
Outer	25	260	245
Inner	16	262	247
Snubber	16	294	279
<b>CASNUB-22HS</b>			
Outer	22	260	245
Inner	18	243	228
Snubber	18	293	278
<b>CASNUB -22HS(Mod-1) BOSTHS</b>			
Outer spring	21.5	253	238
Inner Spring	16.5	225	210
Snubber Spring	16.5	304	289



**(d) Spring Arrangement for Various CASNUB Trolleys**

Wagon type	Bogie	Number of springs per bogie	Axle	Speed as per speed certificate (KMPH)	
				Empty	Load
BOXN	Casnub 22 NLB	Outer -12, Inner-8, Snubber -4	20.32	80	75
			22.32	80	60
			22.82	80	60
BOXNM1	Modified Casnub 22 NLB	Outer -14, Inner-10, Snubber -4	22.32	80	70
			22.82	80	60
BOXNEL	Casnub 22 NLC	Outer -14, Inner-14, Snubber -4	25.00	65	50
BOXNHS	Casnub 22HS	Outer -14, Inner-12, Snubber -4	20.32	100	100
BOXNHSM1	Modified Casnub 22 HS	Outer -14, Inner-14, Snubber -4	22.23	90	75
			22.82	80	60
BOXNHA	IRF 108 HS	Outer -14, Inner-14, Snubber -4	20.32	100	100
			22.1	100	100
			22.82	100	75
BOXNHL	Modified Casnub 22 HS	Outer -14, Inner-14, Snubber -4	22.9	90	70
BOXNLWM1	Modified Casnub 22 HS	Outer -14, Inner-14, Snubber -4	22.32	65	60
			22.82	65	60
BOY	Modified Casnub 22 NLB	Outer -14, Inner-10, Snubber -4	22.86	75	65
BOYEL	Casnub 22 NLC	Outer -14, Inner-14, Snubber -4	25.00	65	50
BOBYN	Casnub 22 NLB	Outer -14, Inner-08, Snubber -4	20.32	75	75
			20.32	65	60
BCN	Casnub 22 NLB	Outer -14, Inner-08, Snubber -4	20.32	80	75
			22.32	80	75
BCNM1	Modified Casnub 22 NLB	Outer -14, Inner-10, Snubber -4	22.32	80	75
			22.82	80	60
BCNA	Casnub 22 NLB	Outer -14, Inner-08, Snubber -4	20.32	80	60
			22.32	80	75
BCNAM1	Modified Casnub 22 NLB	Outer -14, Inner-10, Snubber -4	22.32	80	75
			22.82	80	60
BCNAHS	Casnub 22HS	Outer -14, Inner-12, Snubber -4	20.32	100	100
BCNAHSM1	Modified Casnub 22 HS	Outer -14, Inner-14, Snubber -4	22.32	100	75
			22.82	100	75
BCNHL	Modified Casnub 22 HS	Outer -14, Inner-14, Snubber -4	22.9	75	70
BOST	Casnub 22HS	Outer -14, Inner-12, Snubber -4	20.32	80	75
			22.32	80	50
BOSTM1	Modified Casnub 22 HS	Outer -14, Inner-14, Snubber -4	22.32	65	60
BOSTHS	Casnub 22HS (Mod - I)	Outer -14, Inner-12, Snubber -4	20.32	100	100
BOSTHSM1	Casnub 22HS (Mod - I)	Outer -14, Inner-14, Snubber -4	22.32	80	60
BOSTHSM2	Casnub 22HS (Mod - II)	Outer -14, Inner-12, Snubber -4	22.32	100	60
BOBSA	Modified Casnub 22 NLB	Outer -14, Inner-10, Snubber -4	22.9	75	75
BOBSNM1	Casnub 22 NLC	Outer -14, Inner-14, Snubber -4	25.00	60	50

Wagon type	Bogie	Number of springs per bogie	Speed as per speed certificate ( KMPH)		
			Axle	Empty	Load
BOBR	Casnub 22 NLB	Outer -14, Inner-08, Snubber -4	29.32	80	80
			22.32	75	60
BOBRM1	Modified Casnub 22 NLB	Outer -14, Inner-10, Snubber -4	22.32	75	60
BOBRN	Casnub 22 NLB	Outer -14, Inner-08, Snubber -4	20.32	70	75
			22.32	65	60
BOBRNM1	Modified Casnub 22 NLB	Outer -14, Inner-10, Snubber -4	22.32	80	60
BOBRNHSM1	Modified Casnub 22 HS	Outer -14, Inner-14, Snubber -4	22.32	65	60
BOBRNALHSM1	Modified Casnub 22 HS	Outer -14, Inner-14, Snubber -4	22.32	65	60
BOBRNEL	Casnub 22 NLC	Outer -14, Inner-14, Snubber -4	25.00	65	50
BRN	Casnub 22 NLB	Outer -14, Inner-08, Snubber -4	20.32	80	75
BRNAHS	Casnub 22HS	Outer -14, Inner-12, Snubber -4	20.32	100	100
BFNS	Casnub 22HS	Outer -14, Inner-12, Snubber -4	20.32	100	80
BTPN	Casnub 22 NLB	Outer -14, Inner-08, Snubber -4	20.32	80	80
BTPGNL	Casnub 22 NLB	Outer -14, Inner-08, Snubber -4	20.32	80	75
BLCA	LCCF 20 ( C )	Outer -14, Inner-12, Snubber -4	20.32	100	100
BLBC			20.32	100	100
BLLA			20.32	100	100
BLCA			20.32	75	75
BLBC double stock			20.32	75	75
BLCAM			Modified LCCF 20 ( C )	Outer -14, Inner-14, Snubber -4	22.00
BLCBM Double stock					
BCACM auto car wagon	LCCF 20 ( C )	Outer -14, Inner-12, Snubber -4	20.32	65	65
BRHNEHS	Casnub 22 HS	Outer -14, Inner-12, Snubber -4	20.32	65	50

## Maintenance Issues of Springs:

### 1. Stacking System of Springs-

4-Tier system should be adopted for easy placement & removal of springs.

### 2. Spring loaded dial gauges-

- ▶ Spring height gauges must be kept in spring section section.
- ▶ Spring loaded dial gauges may also be kept inline with NKJ depot.

### 3. Transportation of set of Springs

For safe transportation from sub-store to shop, rectangular wheeled trolleys should be developed & kept in section ( Such trolleys are available in ROH depot TKD & NKJ).

#### **4. Colour Coding/Provision of Band**

- As of now, only local colour coding is in practice in zonal Railways.
- Marking of coloured band on springs is most commonly adopted system in ROH depots. It is recommended that marking of bands may be done for easy grouping of springs in the depots.

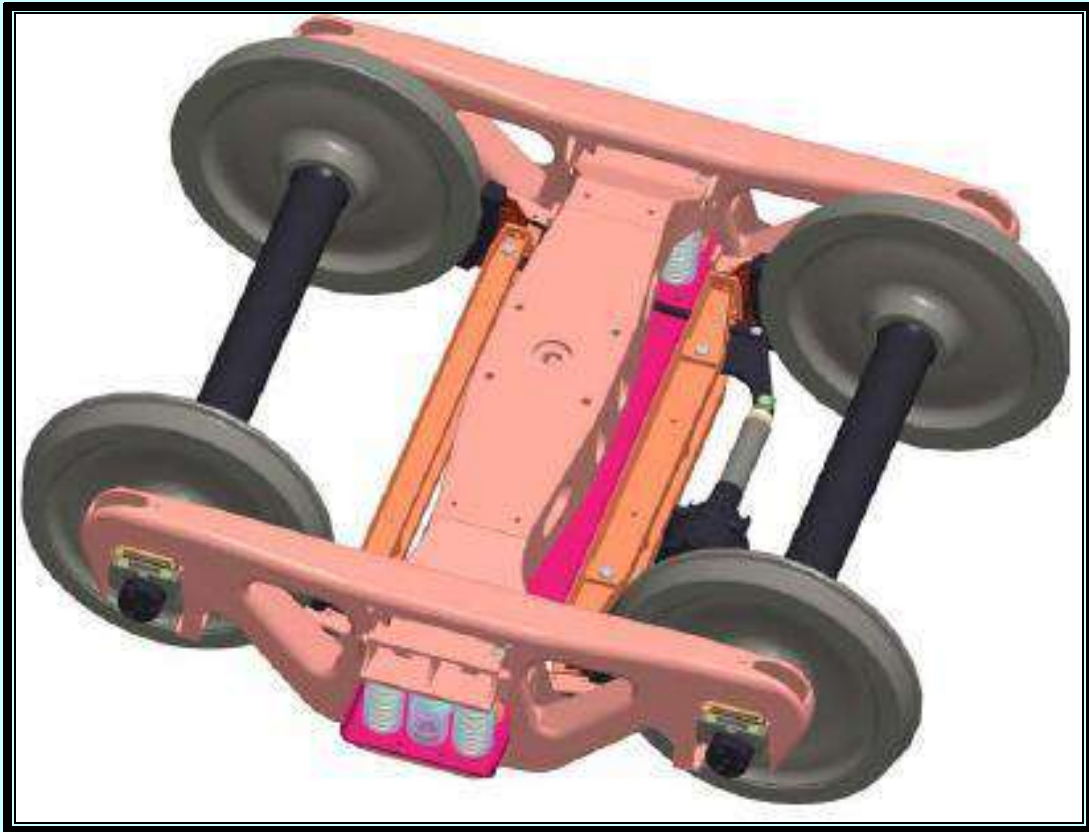
#### **5. Cleaning of springs**

- ▶ Wire brush is being used for cleaning of springs. The practice is useful & be continued.



*( MAINTENANCE MANUAL FOR WAGONS- 2015 )*

# CHAPTER – 7



# AIR BRAKE SYSTEM



## CHAPTER 7

### AIR BRAKE SYSTEM

#### 701. CLASSIFICATION OF AIR BRAKE SYSTEM

On the basis of type of release, air brake system is classified as:

- Direct release air brake system
- Graduated release air brake system

Both Direct and Graduated release are further available in two forms viz.

- Single pipe and
- Twin pipe

The diagram shown in fig. 7.1 illustrates the schematic layout of air brake equipment on the under frame of freight stock. As shown in figure, the single pipe graduated release air brake system consists of following components:-

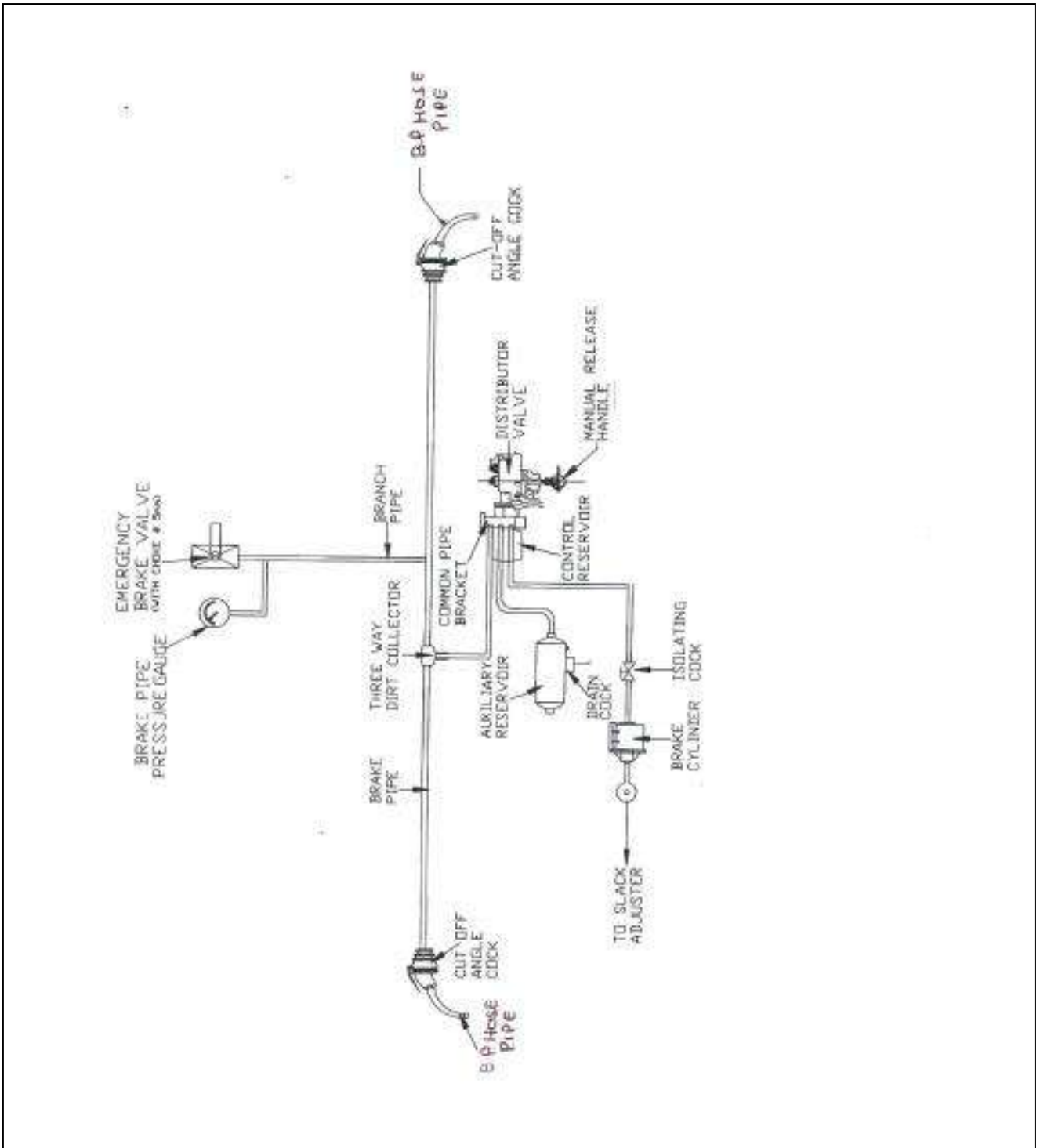
- i) Distributor valve
- ii) Common pipe bracket with control reservoir.
- iii) Auxiliary reservoir.100 Litres & 75 Liters
- iv) Three way centrifugal dirt collector.
- v) Isolating cock.
- vi) Brake cylinder 355mm diameter & 300 mm diameter.
- vii) Cut off angle cock (32mm size on either ends of brake pipe & feed pipe).
- viii) Air brake hose coupling (32mm for brake pipe / 32 mm from feed pipe).
- ix) Brake pipe/feed pipe (32mm dia).
- x) Branch pipes from BP to brake equipment (20mm bore).
- xi) Guard emergency brake valve.
- xii) Pressure gauges for BP
- xiii) Quick Coupling.

Recently, Bogie mounted Brake System (BMBS) has also been introduced for freight stock. The details of BMBS for freight stocks are given in Para 729 of this chapter

#### 702. PRINCIPLE OF OPERATION OF SINGLE PIPE GRADUATED RELEASE AIR BRAKE SYSTEM

Some of the Air Brake goods stock on IR is fitted with single pipe graduated release air brake system. In single pipe, brake pipes of all wagons are connected. Also all the cut off angle cocks are kept open except the front cut off angle cocks of BP of leading loco and rear end cut off angle cock of BP of last vehicle. Isolating cocks on all wagons are also kept in open condition. Auxiliary reservoir is charged through distributor valve at 5.0 kg/cm<sup>2</sup>.





**Fig. 7.1**  
**GRADUATED RELEASE SINGLE PIPE AIR BRAKE SYSTEM**

A. Charging stage

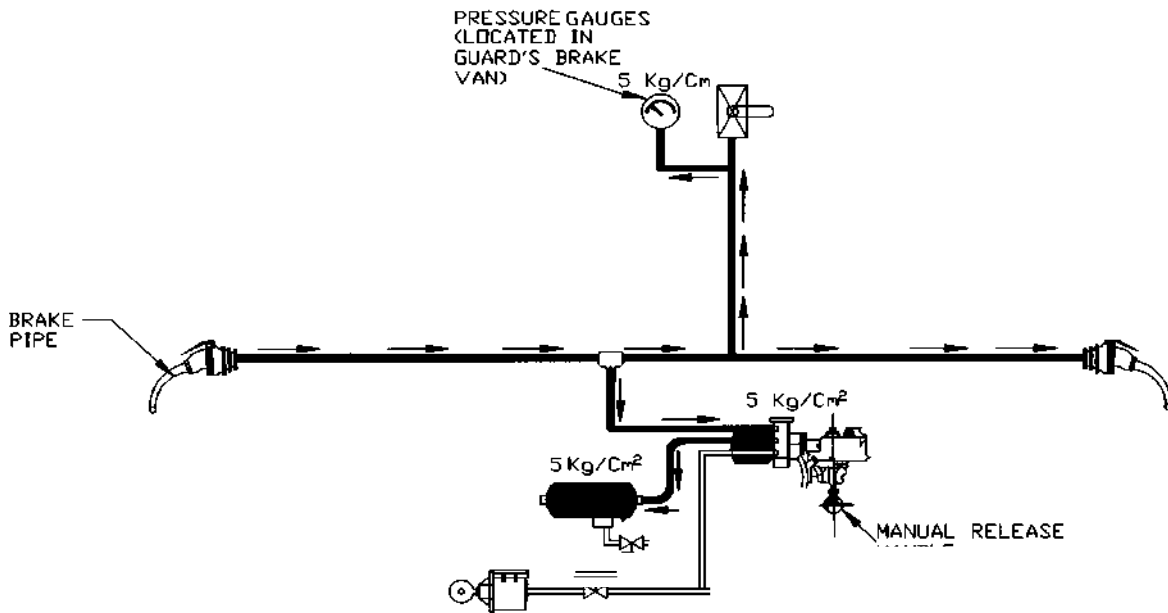


Fig. 7.2 CHARGING

During this stage, brake pipe is charged to  $5\text{kg/cm}^2$  pressure which in turn charges control reservoir and auxiliary reservoir to  $5\text{kg/cm}^2$  pressure via distributor valve. At this stage, brake cylinder gets vented to atmosphere through passage in Distributor valve.

B. Application Stage

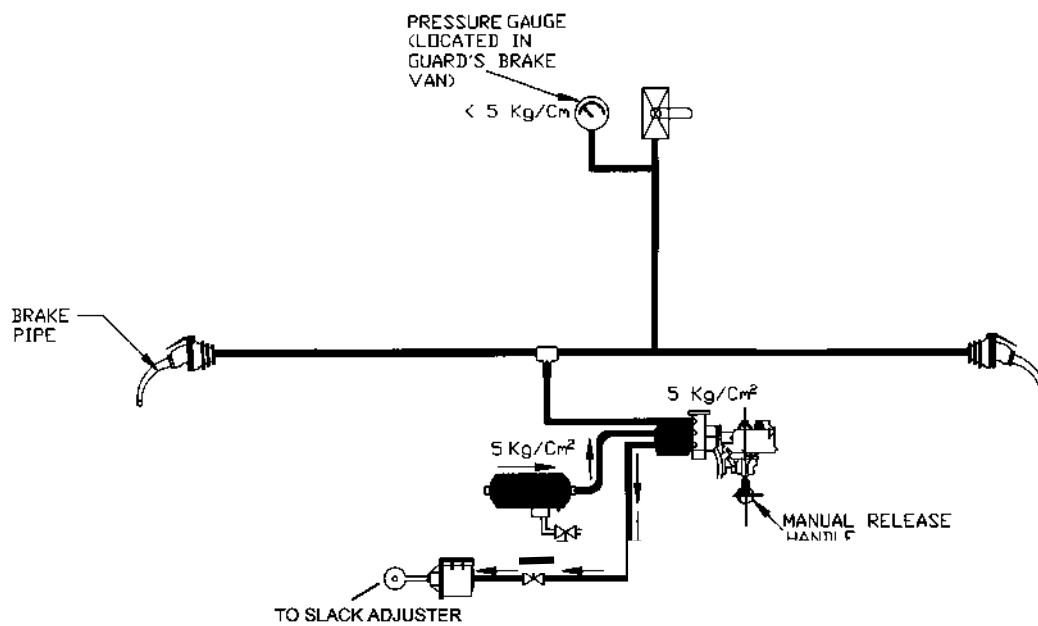
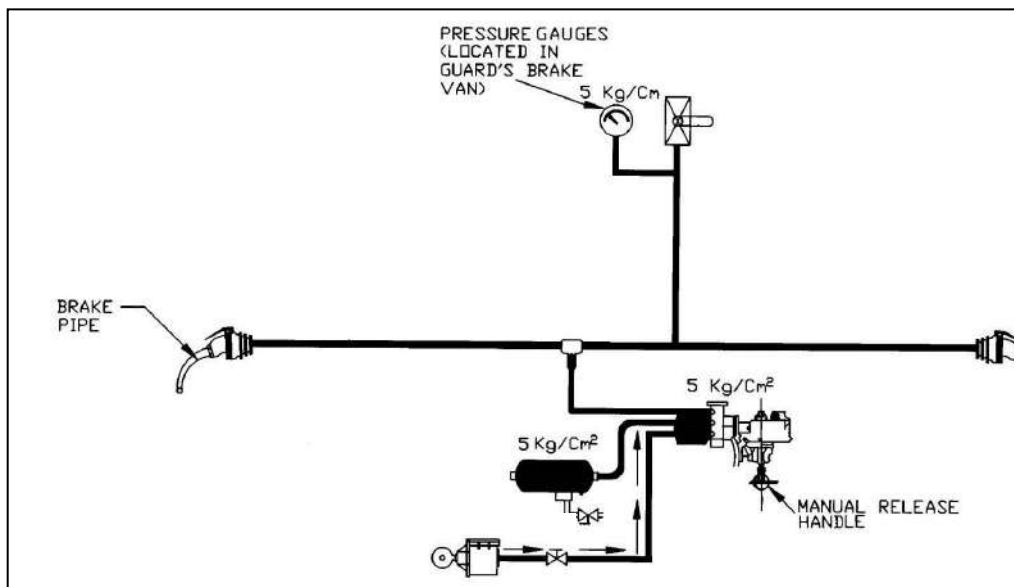


Fig. 7.3 APPLICATION

For application of brakes, the pressure in brake pipe has to be dropped. This is done by venting air from driver's brake valve. Reduction in brake pipe pressure positions the distributor valve in such a way that the control reservoir gets disconnected from brake pipe and auxiliary reservoir gets connected to brake cylinder. This results in increase in air pressure in brake cylinder resulting in application of brakes. The magnitude of braking force is proportional to reduction in brake pipe pressure

- Note:**
1. Brake Application takes places when Brake pipe pressure is dropped.
  2. The drop of pressure may be a) Intentional and b) Accidental.

### C) Release stage



**Fig. 7.4 RELEASE**

For releasing brakes, the brake pipe is again charged to 5 kg/cm<sup>2</sup> pressure by compressor through driver's brake valve. This action positions distributor valve in such a way that auxiliary reservoir gets isolated from brake cylinder and brake cylinder is vented to atmosphere through distributor valve and thus brakes are released

### 702A. PRINCIPLE OF OPERATION OF TWIN PIPE GRADUATED RELEASE AIR BRAKE SYSTEM

Some of the Air Brake goods stock on IR is fitted with Twin pipe graduated release air brake system. In Twin pipe, brake pipes and feed pipes of all wagons are connected. Also all the cut off angle cocks are kept open except the front cut off angle cocks of BP/ FP of leading loco and rear end cut off angle cock of BP and FP of last vehicle. Isolating cocks on all wagons are also kept in open condition. Auxiliary reservoir is charged to 6.0 Kg/cm<sup>2</sup> through the feed pipe.

#### A. Charging stage

During this stage, brake pipe is charged to 5 kg/cm<sup>2</sup> pressure and feed pipe is charged to 6 kg/cm<sup>2</sup> pressure which in turn charges control reservoir and auxiliary reservoir to 6 kg/cm<sup>2</sup> pressure. At this stage, brake cylinder gets vented to atmosphere through passage in Distributor valve.

**B. Application Stage**

For application of brakes, the pressure in brake pipe has to be dropped. This is done by venting air from driver's brake valve. Reduction in brake pipe pressure positions the distributor valve in such a way that the control reservoir gets disconnected from brake pipe and auxiliary reservoir gets connected to brake cylinder. This results in increase in air pressure in brake cylinder resulting in application of brakes. The magnitude of braking force is proportional to reduction in brake pipe pressure

**Note:** 1. Brake Application takes places when Brake pipe pressure is dropped.  
2. The drop of pressure may be a) Intentional and b) Accidental.

**C. Release stage**

For releasing brakes, the brake pipe is again charged to 5 kg/cm<sup>2</sup> pressure by compressor through driver's brake valve. This action positions distributor valve in such a way that auxiliary reservoir gets isolated from brake cylinder and brake cylinder is vented to atmosphere through distributor valve and thus brakes are released.

**Do's and Don'ts for Twin Pipe working of Freight Trains****Do's:**

1. Do ensure that the all twin pipe Wagons are operated in CC rakes only.
2. Do ensure that loco provided for twin pipe rake is having its twin pipe in working condition.
3. Do ensure availability of spare pool of twin pipe wagon & brake van, for replacement, if required.
4. Do ensure availability of spare feed pipe in loco.
5. Do ensure that brake van provided for twin pipe working is having twin pipe system.
6. Do ensure BP coupling heads are marked with 'BP' and painted in green.
7. Do ensure FP coupling heads are marked with 'FP' and painted in white.
8. Do ensure that BP & FP hose couplings at the rear end of the train are placed on their respective hose coupling supports.
9. Do ensure that pressure gauges for BP and FP are provided in the brake van.
10. Do ensure that brake pipe/feed pipe angle cocks are not closed under any circumstance, either for isolation of wagons or for any purpose whatsoever, except for carrying out shunting operation, after which the angel cocks should again be opened to ensure continuity of brake pipe and feed pipe.
11. Do ensure that the isolating cock of feed pipe of all the wagons in the open position. The handle of cock shall be vertically down when open and at horizontal when closed.
12. Do ensure that gauge in guards compartment show pressure not less than 5.8 kg/cm<sup>2</sup> in feed pipe after the system is fully charged.
13. Do ensure that feed pipe hose coupling are connected to form a continuous passage from locomotive to last vehicle.
14. Do ensure that feed pipe Cut off angle cocks, except at the rear of train, are kept open.
15. Do ensure availability of the quick coupling for attaching and detaching the pressure gauges for BP/FP in brake van.

16. Do ensure that the leakage in brake system is less than  $0.25\text{kg/cm}^2$  per minute.
17. Do close BP/FP angle cocks of adjacent wagons to uncouple hose couplings.

### DON'Ts

1. Do not allow single pipe coupling.
2. Do not allow a feed pipe to be connected to the brake pipe anywhere in the train or vice versa.
3. Do not allow a feed pipe hose coupling at rear end to dangle.
4. Do not allow train to leave with leakage higher than specified.
5. Do not allow train to leave with feed pipe pressure in loco and brake van less than specified.

### UNCOMMON ITEMS FOR TWIN PIPE AIR BRAKE SYSTEM

Items	Description & dimensions	Nos./ Wagon	Ref. Drg.
1.	AIR BRAKE HOSE COUPLING (F.P.)	2	WD-81027-S-01
2.	ISOLATING COCK	1	WD-83062-S-04
3.	CHECK VALVE	1	WD-83062-S-03
4.	PIPE 20 N.B.	1	Respected drawings of different wagons.
5.	PIPE 20 N.B.	1	
6.	PIPE 20 N.B.	1	
7.	PIPE 32 N.B. (F.P.)	1	
8.	PIPE 32 N.B. (F.P.)	1	

### MARKING OF TWIN PIPE AIR BRAKE FITTED WAGONS

For easy identification of these wagons, 'Twin Pipe' written in black letters on yellow background and encircled in white band shall be marked on side panel, one side in English and other side in Hindi as specified in RDSO drawings.

**NOTE:** For further details please refer Annexure XIX of G-97 amendment No. 3 of Jan. 2010 for "General guidelines for operation and examination of Twin Pipe Air Brake system of complete train" and RDSO report No. MP. Guide No. 11 (Rev. -01) "Procedure for checking of Diesel/Electric locomotive Hauled Air Braked Trains (Fitted with twin pipe air brake system)"

### AIR BRAKE SUB ASSEMBLIES

#### 703. COMMON PIPE BRACKET

Common pipe bracket is permanently mounted on the under frame of a vehicle. The distributor valve along with the intermediate piece (sandwich) which houses the isolating cock is mounted on one face of the common pipe bracket. The control reservoir is mounted on the other face of the Common pipe bracket.

The Common pipe bracket has been evolved with the purpose of making it suitable for use with any make of distributor valve adopted on Indian Railways.

Common pipe bracket is a sturdy casting with internal air passages, matching the intermediate piece mounting face with accurately profiled air cavities and flanged ports leading to the appropriate ports of the distributor valve.

Branch pipes to the brake pipe and brake cylinders are fitted on the appropriate ports on the common pipe bracket. The advantage of fitting a common pipe bracket is to remove the distributor valve for repair or replacement without disturbing the pipe connections.

#### 704. INTERMEDIATE PIECE (SANDWICH PIECE)

Intermediate piece serves the purpose of blanking all the other ports on the common pipe bracket front face other than required for a particular make of distributor valve. Each type of distributor valve is mounted on the common pipe bracket with its own intermediate piece (sandwich).

Intermediate piece is mounted on the common pipe bracket face with a common gasket and the distributor valve is fastened to the intermediate piece. Isolating cock for distributor valve, which is housed in the intermediate piece is for isolating the distributor valve in case of malfunctioning or for disconnecting the brake pipe pressure. Isolating cock on intermediate piece has a built in venting arrangement.

#### 705. BRAKE PIPE HOSES

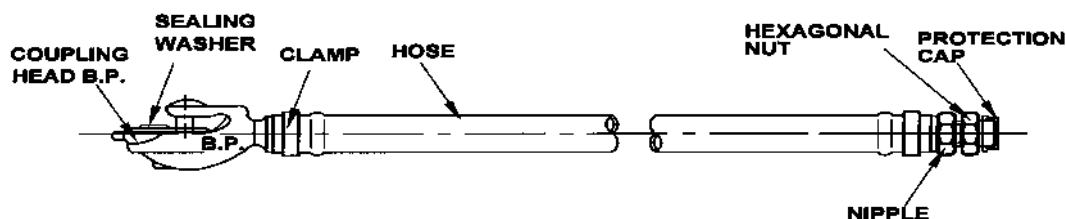


Fig. 8.5

In order to connect two successive wagons, the brake pipes (BP) & Feed Pipe (FP) installed on the underframe are fitted with flexible hoses. The hoses are named as BP/FP hose.

#### 706. BRAKE PIPE COUPLING

To connect subsequent wagons, the hoses of BP are screwed to coupling and hose nipple by means of stainless steel 'Bend it' type clips. The coupling is specially designed in the form of palm end and hence also known as palm end coupling. For easy identification the couplings are engraved with letter BP and coupling heads are painted green.

**Note:** Design, controlling dimensions, material and specification of components shall conform to the latest revision of RDSO drg. No. SK-73547 for BP, WD-81027-S-01 for FP and appendix F of 02 ABR 02 of RDSO specification.

The air brake hose couplings are provided in the brake pipe line throughout the train for connecting the brake pipe of adjacent wagons to form the complete rake. Each Air Brake Hose coupling consists of a specially manufactured rubber hose clamped over a

WAGON MAINTENANCE MANUAL

nipple on one end and a coupling head on the other end. Rubber sealing washers are provided on the outlet port of the coupling head.

Since a joint is formed at the coupling head, leakage may take place, through it. Therefore it is necessary to subject the hose coupling of brake pipe to leakage test.

## A. TOOLS AND EQUIPMENTS

### a) Test stand (Fig. 7.6)

*Test stand for testing of the hose coupling consists of the following main equipment*

- 1) Supply of compressed air at – 10 Kg/cm<sup>2</sup>
- 2) Isolating cock – 1a and 1b
- 3) Exhaust cock – 1c
- 4) Main reservoir
- 5) Pressure gauge
  - 6a for main reservoir
  - 6b for flexible hose
- 6) Flexible hose - for connecting hose coupling for immersing in to water.
- 7) Water tub with safety cage – for checking leakage from hose coupling.
- 8) Dummy coupling head.

### b) TEST PROCEDURE

*For testing the hose coupling the steps given below should be followed:*

- i. Use a dummy coupling head to block the outlet port of the hose coupling.
- ii. Connect to hose coupling under test to the end of flexible hose.
- iii. Open isolating cock 1(a)
- iv. Adjust pressure regulator (2) so that pressure gauge (6a) shows 10Kg./cm<sup>2</sup> air pressure.
- v. Immerse the hose coupling assembly completely in the tub of water.
- vi. Open isolating cock (1b) and see that (6b) shows 10 Kg/cm<sup>2</sup> pressure.
- vii. Observe leakage, if any from all parts of the hose coupling.
- viii. Close the isolating cock 1(b).
- ix. Disconnect the hose coupling from test bed.
- x. If the leakage is observed through the coupling head, replace the gasket and test again.
- xi. If leakage persists even after change of gasket the coupling head is unserviceable and complete assembly shall be rejected. However if leakage occurs at the hose nipple or coupling end hose joint the clamp should be attended/replaced to make the assembly leak proof.

### c) SAFETY PRECAUTIONS

- Specified tools and fixtures should be used for connecting and disconnecting the hose coupling with the air supply.
- While testing the hose coupling before charging it to 10kg/cm<sup>2</sup> pressure, the tube should be covered and locked with a protective cage.

- Exhaust the pressure from the hose coupling under test, before lifting the safety cage and uncoupling it.
- After testing, the hose assembly shall be stored in a dry and clean space. The inlet and outlet port must be plugged with protective cap to prevent entry of dust and foreign particles inside the hose coupling.

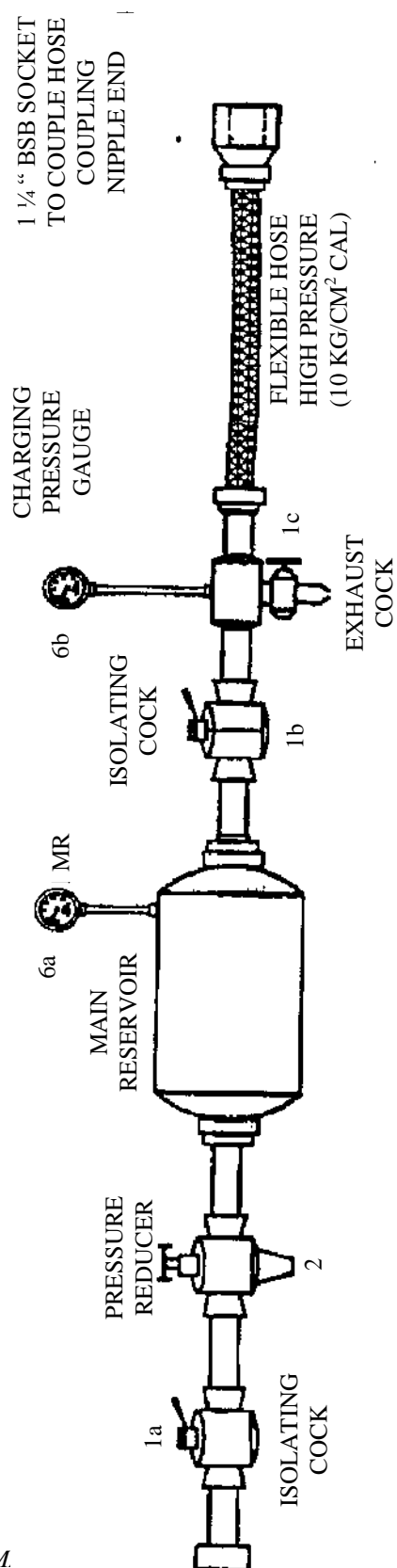
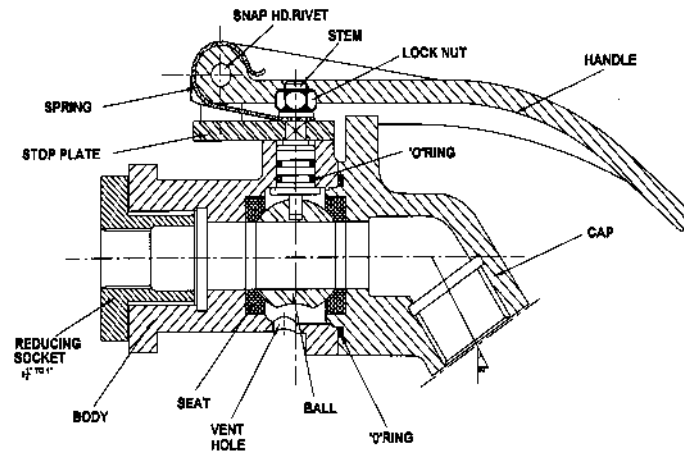


Fig.7.6 TESTING OF HOSE COUPLING



## 707. CUT OFF ANGLE COCK



**Fig. 7.7**

Cut off angle cocks are provided on the air brake system to facilitate coupling and uncoupling of air hoses (i.e. brake pipe). When the handle of the cut off angle cock is placed in closed position it cuts off the passage of compressed air, thereby facilitating coupling and uncoupling action.

If coupling action has to be performed on a given rake, ensure that the cut off angle cock provided at the end of the brake pipes are closed. By doing this the compressed air gets cut off and does not enter into the brake pipe air hose. The air hoses without compressed air can thus easily be coupled without any jerk. Similarly during uncoupling the cut off angle cocks of subsequent wagons should be closed. By doing so the air present in the brake pipe air hose gets leaked through the vent provided in the body of the cut off angle cock. Finally the air hoses get emptied and thus can be easily uncoupled without any jerk.

The cut off angle cock consists of two parts viz. cap and body which are secured together by bolts. The cap and the body together hold firmly the steel ball inside it, which is seated on rubber seat. The ball has a special profile with the provision of a groove at the bottom portion for venting the air to the atmosphere.

On the top surface of the body a bore is provided for placing the stem, to which a self locking type handle is fixed. When the handle is placed parallel to the cut off angle cock the inlet port of the cut off angle cock body is connected to the outlet port, through the hole provided in steel ball. Thus air can easily pass through the cock. This position of the handle is known as open position. When the handle is placed perpendicular to the cock body the steel ball gets rotated and the spherical and groove portion of the ball presses against the sealing ring at inlet and outlet port, thereby closing the passage of inlet air and venting the outlet air through the vent hole. This position of the handle is known as closed position.

With the stem one leaf spring is provided which presses the operating handle downwards. By virtue of this, handle gets seated in deep grooves at ON/OFF position resulting in a mechanical lock.

Under normal working conditions, the handle of all cut off angle cock of BP are kept open except the rear end angle cock (BP). This facilitates in charging the complete air brake system with compressed air supplied by the compressor housed in the locomotive. Cut off angle cock fitted on the brake pipe is painted green.

**Note:** The dimension and tolerances of cut off angle cock shall be as indicated in latest revision of RDSO drawing nos. WD-88123-S-01 and WD-88123-S-02.

Since a number of manufacturers exist for air brake equipment and component, refer to concerned original manufacturer's maintenance manual for part no. and description of spares.

### **A. OVERHAULING OF CUT OFF ANGLE COCK**

These angle cocks are of ball-type ensuring better sealing against leakage and facilitate ease of operation. During overhauling, it is dismantled for cleaning, replacement of parts and checking for effective functioning.

The cut-off angle cock is to be completely dismantled and overhauled during POH or when there is some specific trouble.

#### **a) TOOLS & EQUIPMENT**

The following tools and fixtures are required for overhauling

- (I) Single end spanner.
  - 1) A/F 17 for M10 nut pivot screw.
  - 2) A/F 10 for M6 nut.
- (II) Screw driver 12"/300 mm long.
- (III) Vice.
- (IV) Light hammer.

#### **b) PROCEDURE**

##### **Dismantling**

- Hold the cut – off angle cock in vice.
- Unscrew the lock nut from the stem.
- Take out the handle assembly (The handle assembly need not be dismantled further unless it is necessary to change the plate spring i.e. if it is found, heavily rusted, pitting crack or the spring is permanent set).
- Unscrew the four hexagonal bolts and spring washers.
- Detach cap from the body.
- Remove 'O' ring and ball seat from the cap.
- Turn the stem in such a way that the ball can be pulled from the stem.
- Slightly hammer the stem at its top and take out the stem through the bore of the body.
- Remove the ball seat from the body.

#### **c) Cleaning of Parts**

- Clean out side portion of the body and cap with wire brush.

- Direct a jet of air to remove the dust.
- Clean all metallic parts with kerosene oil and wipe dry.

#### **d) Replacement of Parts**

- Replace all rubber parts.
- Replace spring-washer, nut & bolts in case they are excessively corroded or defective.
- Replace handle spring if it is found heavily rusted, is having pitting crack or is permanently set (Dismantle the handle assembly, and fit a new spring along with a snap head rivet).
- Replace stainless steel ball if found with scratch marks on the outer surface or dented.

#### **e) Assembly**

- Insert the two 'O' rings in their respective grooves on the stem.
- Keeping the threaded end of the stem first, insert the stem into the body through the bore of the body.
- Place one ball seat in its groove inside the body.
- Position the ball after correctly aligning its venting slot in the bore of the body.
- Place the second ball seat and 'O' ring in their respective positions on the cap.
- Secure the body and cap by Hex. Hd. Bolt (M6) and spring washer (for M6).
- Place the handle assembly on the stem and secure it with Hex. Hd. Nut (M10).
- During assembly apply a light coat of shell MP2 or equivalent grease on the external surface of the threads and the ball.

## **B. TESTING OF CUT-OFF ANGLE COCK**

### **a) TOOLS AND EQUIPMENT**

- i. Test Bench
- ii. Compressor to build pressure more than 10 kg/cm<sup>2</sup>.
- iii. Single ended spanner as per IS 2027
  - a) Across face 17 (for M10 lock nut) - 1 No.
  - b) Across Face 13 (for M8 studs) 2 No.
- iv. Screw Driver –300mm, 1 No.
- v. 1 ¼ “ BSP dummy Plug with seal.
- vi. Dummy plug for angle cock.

**b) TEST PROCEDURE**

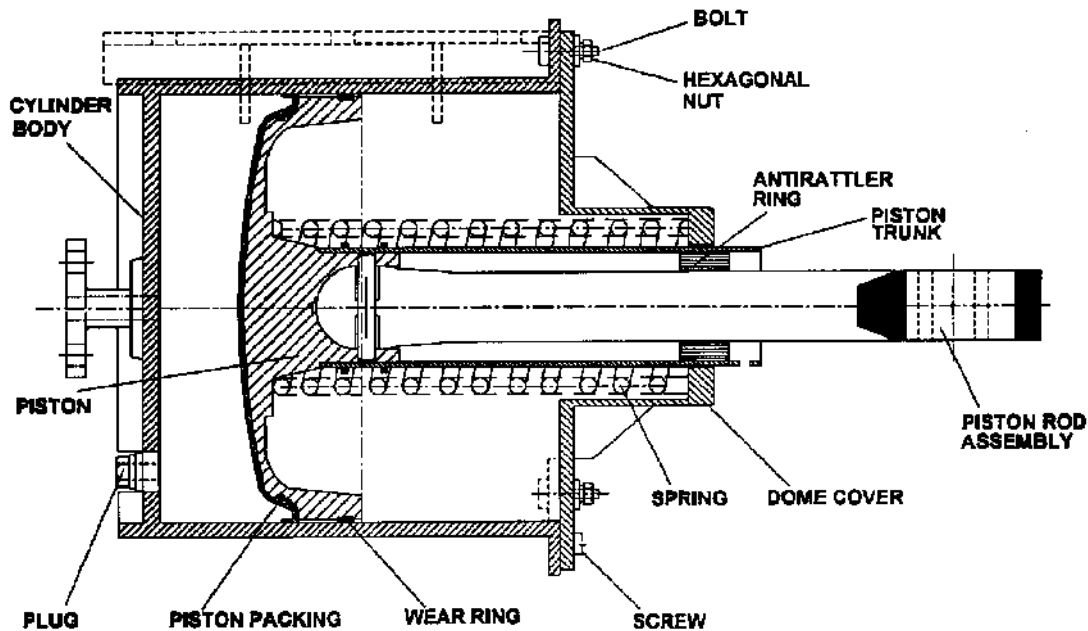
Following test procedure should be adopted step by step for performing the leakage test.

- i. Mount the angle cock on the base of the test bench (Part No. 7 of the figure of the test bench).
- ii. Move the handle to the closed position.
- iii. See that cock (1e) and (1c) are in closed position.
- iv. Now open cock 1(a) and 1(b) till MR indicates a pressure of 10 Kg/Cm<sup>2</sup>.
- v. If necessary, adjust pressure regulator (2) to maintain the pressure at 10 kg/Cm<sup>2</sup>.
- vi. Open cock (1c) and check the leakage with soap solution. There should not be any leakage.
- vii. Check pressure drop in gauge (6b) there should not be any leakage from flange joints, vent and outlet port of the angle cock.
- viii. Close cock (1c) and tighten the dummy plug and seal the outlet of the angle cock.
- ix. Move the handle to the open position. Open cock 1c.
- x. Check for leakage from body and cap joint, vent and all over the stem periphery using soap water. No leakage is permissible.
- xi. Move the handle to closed position and notice a short blast of air through the vent.
- xii. Close cock 1c then Open cock (1d) and exhaust the pressure to zero.
- xiii. Remove the angle cock.
- xiv. Report results of the test.

**c) SAFETY PRECAUTIONS**

- Specified tools and fixtures should be used for assembly and disassembly operations.
- The small metal parts like leaf spring, nut, bolts, washers, screws etc should be kept in a safe place and replaced in case found defective.
- Inlet and outlet port of the tested angle cock should be plugged with protection cap to prevent entry of dust and moisture inside the cut off angle cock.
- Ball should be handled carefully to avoid any damage on its surface.
- Threaded portion of body and cap should not be damaged at the time of dismantling.

## 708. BRAKE CYLINDER



(Note: Anti-rattler ring shall be provided on brake cylinder for passenger stock)

Fig. 7.8 BRAKE CYLINDER

On every wagon fitted with air brake system one brake cylinder is provided for actuating the brake rigging for the application and release of brakes.

During application stage the brake cylinder receives pneumatic pressure from the auxiliary reservoir after being regulated by the distributor valve. There after the brake cylinder develops mechanical brake power by outward movement of its piston assembly. To transmit this power to the brake shoe, the push rod of piston assembly is connected to the brake shoe through a system of levers to amplify and transmit the brake power. During release action of brakes the compression spring provided in the brake cylinder brings back the rigging to its original position.

The cylinder body is made out of sheet metal or cast iron and carries the mounting bracket, air inlet connection, ribs and flange. To the cylinder body, a dome cover is fitted with the help of bolts and nuts. The dome cover encloses the spring and the passage for the piston trunk, which is connected to the piston by screws. The piston is of cast iron having a groove in which piston packing is seated. Piston packing of rubber material which is of oil and abrasion resistant and unaffected by climatic changes. It is snap fit to the piston head and has self lubricating characteristic which ensures adequate lubrication over a long service period and extends seal life considerably

The piston packing also seals the air- flow from the pressure side to the other side and is guided by the wear ring. The wear ring prevents the friction between cylinder body and the piston head. The piston sub assembly incorporates a push rod, which can articulate and take minor variations in alignment during fitment/operation.

**Note:** The dimension and tolerances of brake cylinder shall conform to the latest revision of RDSO drawing number WD-92051-S-06, WD-92051-S-07, WD-92051-S-08, WD-92057-S-09, WD 92051 -S-09, WD 94048-s-01, WD 92051 -S-11, WD 92051 -S-12, WD 92051 -S-13, WD 92051 -S-14 and WD 92051 -S-15.

## A. OVERHAULING OF BRAKE CYLINDER

Brake cylinder has to be thoroughly overhauled for efficient and reliable trouble free performance during its prolonged service life. The complete overhauling of the brake cylinder is to be carried out during POH or when there is some specific trouble.

### a) TOOLS & EQUIPMENT

Sr. No.	Description
1.	Torque Wrench 0-3 Kg range
2.	Double End Spanner 24x27 mm across face (For M16)
3.	Double End Spanner across face 13x14 (For M12)
4.	Socket Wrench 19 mm (For M12)
5.	Screw Driver 12" (300 mm)
6.	Special fixture (Screw press/ Pneumatic)
7.	Gauge for examining bore of the cylinder

### b) Dismantling of Brake Cylinder

Before dismantling the dome cover insert a rounded head pin of 12x25 long and secure one of the hole in the piston trunk for the purpose of safety to prevent dome cover working out of the piston rod due to the cylinder return spring force while opening the dome cover with the help of a special fixture clamp the dome cover.

- Unscrew the Hex. Hd. nut and take out the spring washer on the dome cover.
- Turn the handle of the fixture to release the clamp and withdraw the holding clamp of the fixture till the return spring inside the cylinder is fully expanded and free.
- Remove the dome cover and take out the return spring.
- Remove the bush on the rod and brake cylinder.
- Remove the piston rod sub-assembly, piston ring packing, wear ring and slide out the anti rattler ring from the piston rod.
- Unscrew the CSK, head screw and separate the piston, pin, piston trunk & piston rod assembly.
- Unscrew the brake cylinder plug at the rear end.

### c) Cleaning of Parts

- Blow a jet of air to clean the dust on the external surface.
- Clean the metallic parts using wire brush and kerosene oil.
- Clean the internal parts with nylon bristle brush.
- Clean piston packing, wear ring and rubber parts with soap water solution.

**d) Replacement of Parts**

- Replace return spring in case of crack, kinks or permanent set.
- Replace the brake cylinder body if found with deep marks, heavily corroded, or the bore is worn uneven or having ovality.
- Replace all rubber parts.
- If piston trunk is worn excessively it should be replaced.
- Replace piston and piston rod for damages, bent etc.
- Replace dome cover for damage, damaged hole etc.

**e) Inspection and Repairs of the Parts**

Examine visually that the internal surface is free from scratches, rust.

- Brake cylinder bore to be checked for ovalness with proper gauge.
- Check the characteristics of the return spring.
- Piston trunk to be checked for wear and tear.
- Pin, piston rod should be checked for wear.
- Dome cover shall be checked for excessive wear and if worn build up with welding and thereafter re-bore to the required size.
- Gauge bush bore of the piston rod, replace it if worn.

**f) Testing Of Brake Cylinder Body for Leakage**

Before assembly, put dummy plate on the dome side and subject the brake cylinder for hydraulic pressure of 10 kg/cm<sup>2</sup> for 5 minutes. No leakage is permitted.

**g) Assembly of Brake Cylinder**

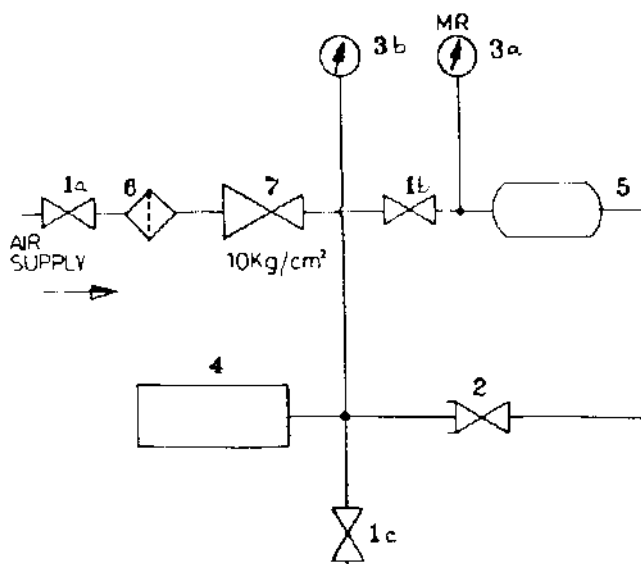
Assemble piston rod, pin, and piston trunk on piston, tighten CSK screws to piston trunk and piston.

- Slide anti-rattler ring from the piston front side.
- Assemble piston return spring on the piston head and insert the dome cover over the piston trunk.
- Insert  $\phi$  12 x 25 mm long head pin into the hole provided in the extended portion of the trunk.
- Smear the piston head & inside the cylinder body with MP 2 grease or equivalent.
- Ease the packing into the cylinder with a wooden spatula with a round nose and round edge to avoid damage to the piston packing.
- Push the piston assembly approximately to the central position of the cylinder.
- With the help of special fixture, bring down the dome cover on to the cylinder body and fasten the 8 Hex. HD bolt, nut and spring washer with required torque.
- Take out the  $\phi$  12x25 long pin from the piston trunk hole.
- Fit back the plug at the rear of the cylinder.
- Fit the new piston packing and wear ring.

**B. TESTING OF BRAKE CYLINDER****a) BRAKE CYLINDER TEST BENCH (Fig. 7.9)**

Test bench consists of the following main parts

- i. 3 nos. of isolating cocks
- ii. Isolating cock with 1mm choke
- iii. Pressure reducing valve



**Fig. 7.9 TEST BENCH FOR BRAKE CYLINDER**

- iv. 2 Nos. Pressure gauges
- v. Pipe line filter
- vi. Brake cylinder pressure mounting base with safety guard
- vii. Air reservoir
- viii.

**b) TOOLS REQUIRED DURING TESTING**

- i. Torque wrench range (2-3 kgM capacity) – One number.
- ii. Double ended spanner (M16) across face 24x27 – One number.
- iii. Socket wrench (M12) across face 19 – One Number.
- iv. Double ended spanner (M8) across face 13x14 – One number.
- v. Screw Driver – 300mm – One number.

After the overhauling of the brake cylinder, it is mounted on the test bench and tested. It should be operated a few times on the test bench to ease the piston. Each brake cylinder after its maintenance and overhaul shall be subjected to the following tests on the test bench.

Arrangement as shown in Fig. 7.9 is used for testing.



**c) STRENGTH TEST**

*Follow the procedure as given below.*

- i. Place the brake cylinder on base (4) and connect the line to brake cylinder. Brake cylinder stroke should be free.
- ii. Close the safety guard, close the cock (1c).
- iii. Open cock (1b) and let reservoir pressure reach 10 Kg/cm<sup>2</sup>. Check the pressure in MR gauge (3a).
- iv. Open cock (2) till the pressure reaches 6 Kg/cm<sup>2</sup> in pressure gauge (3b).
- v. Close the cock (2) and wait for 2 minutes.
- vi. Open cock (1c).

The above test should be done with the safety guard.

**d) PRESSURE TIGHTNESS TEST**

Follow the following procedure.

Mount the cylinder on the test stand and tighten the mounting bolts & nuts.

- i. Set the brake cylinder stroke at  $85 \pm 10$  mm.
- ii. Open cock (2) and let the pressure gauge (3b) reaches 0.8 Kg/cm<sup>2</sup>.
- iii. Close the cock (2) and wait for 1 minute till the pressure stabilise in gauge (3b).
- iv. Check for the pressure drop which should not be more than 0.1 Kg/cm<sup>2</sup> in 10 minutes.
- v. Open cock (1 c)
- vi. Repeat the test at 130 + 10 mm piston stroke and 3.8 Kg/cm<sup>2</sup> pressure. Close cock (2) open cock (1c). Remove the brake cylinder.

If pressure is not correct or leakage rate is higher, dismantle the brake cylinder and examine piston packing wear ring for proper fitment. Examine plug for leakage. Reassemble the components and retest.

**e) PAINTING**

The exterior of the brake cylinder shall be painted with black enamel paint.

**f) STORING**

Assembled or dismantled brake cylinder should be stored in such a way to prevent the following.

- Flange surface should be prevented from damages.
- Inlet and outlet port should be plugged with protective cap to prevent the entry of dust and moisture inside the brake cylinder.

**g) PRECAUTIONS DURING TESTING**

- Safety Guard should be used during the strength test.
- Assembled or dismantled brake cylinder should be stored in such a way to prevent the following:
  - i. Flange surface should be prevented from damage.

- ii. Inlet port should be plugged with a protective cap to prevent the entry of dust and moisture inside the brake cylinder.
  - Avoid damage to piston packing by dull or sharp edged thin bladed tool.
  - Fit 12 dia, 25 mm long round headed pin on the hole provided in the extended portion of trunk surface before loosening the cover bolts.
  - Excessive lubrication of the cylinder must be avoided.
  - Specified tools and fixtures should be used for handling, mounting and removing the brake cylinder from the test bench.
  - The small metal parts like springs, washer, screws, nuts, bolts, washers should be kept in a safe place and replaced in case found defective.

## **709. DIRT COLLECTOR**

### **A. FUNCTION OF DIRT COLLECTOR**

Dirt Collector is placed in the brake pipe line at a point from where a branch is taken off to the distributor valve. As the name indicates the purpose of the dirt collector is to protect the distributor valve and the auxiliary reservoir by trapping dust and other foreign matters from the compressed air before it enters into the distributor valve and the auxiliary reservoir. This action is achieved by centrifugal action. Hence it is also known as centrifugal dirt collector. The dirt collector ensures inter vehicular full flow of dirt free compressed air to the auxiliary reservoir and the distributor valve through the branch pipes. When the air enters into the body of the dirt collector tangentially through port 'A' it passes down through inverted case in a spiral path. Due to the velocity of air flow, dirt particles get flung outwards. There after they slide down & collect at the bottom.

### **B. SALIENT FEATURES OF DIRT COLLECTOR**

The air entering into the dirt collector from the brakepipe is guided through suitably shaped passage in dirt collector body to produce centrifugal flow. The air is then filtered through additional filter assembly before it is passed to outlet on branch pipe side to provide dust proof air to the distributor valve /auxiliary reservoir after arresting fine dust particles. The dirt contained in the air descends down and gets deposited in the dirt chamber. However, fine particles are also arrested in the filter assembly. The dust particles accumulated in the dirt chamber are removed by opening the drain plug. Rubber gasket is provided between the cover and housing to prevent leakage. Similarly leather washer is provided between the housing and the drain plug to prevent leakage.

**Note: The dimensions and tolerance of dirt collector shall be as indicated in latest revision of RDSO drawing number WD-92051-S-03, WD-92051-S-04 and WD-92051-S-05.**

The dirt collector is to be completely dismantled and overhauled once in 5 years or after 8 lakhs kilometers whichever is earlier or when there is some specific trouble.

### **C. TOOLS AND FIXTURES**

The following tools and fixtures are required for overhauling:

- a) Spanner 19 x 22mm
- b) Vice.
- c) Screw Driver

### **D. PROCEDURE FOR MAINTENANCE**

#### **I. Disassembly**

Hold the dirt collector in vice.

- Loosen drain plug and remove it completely from housing.
- Remove top cover and seal by loosening four hexagonal nuts and removing hexagonal bolts.
- Remove filter from body.

#### **II. Cleaning of Parts**

- Clean all metallic parts using brush and kerosene oil.
- Clean filter with soap water.
- Check all parts for any damage.

#### **III. Replacement of Parts**

- Replace sealing ring and gasket.
- Replace filter.
- Check spring washer and replace in case defective or excessively corroded.

#### **IV. Assembly**

- Assemble body after smearing grease.
- Locate filter in position and assemble top cover with new gasket.
- Fix hexagonal bolts/nuts along with the spring washer.
- Fix new sealing ring to the bottom and assemble drain plug.

### **E. TESTING OF DIRT COLLECTOR**

Centrifugal Dirt Collector is provided at the junction of the main pipe and branch pipe in brake pipes. There are three purposes for providing the dirt collector.

- i. To ensure inter-vehicular full flow of brake pipe lines.
- ii. For branching and feeding to the distributor valve.
- iii. To remove dust and scale particles from the air prior to entering the distributor valve and the air reservoir.

As Dirt collector is subjected to high air pressure it has to be tested for the leakage and strength. Testing of dirt collector is needed after its overhauling. There may be various causes due to which overhauling and subsequent testing of the dirt collector is required.

**F. TOOLS AND EQUIPMENT**

- Test Bench (Fig. 7.10)
- Compressor, capable of building air pressure up to 10 kg/sq. cm.
- Double ended spanner (Across Face 19x22) – One No.
- Dummy flange for dirt collector – 2 nos.

**G. TEST PROCEDURE**

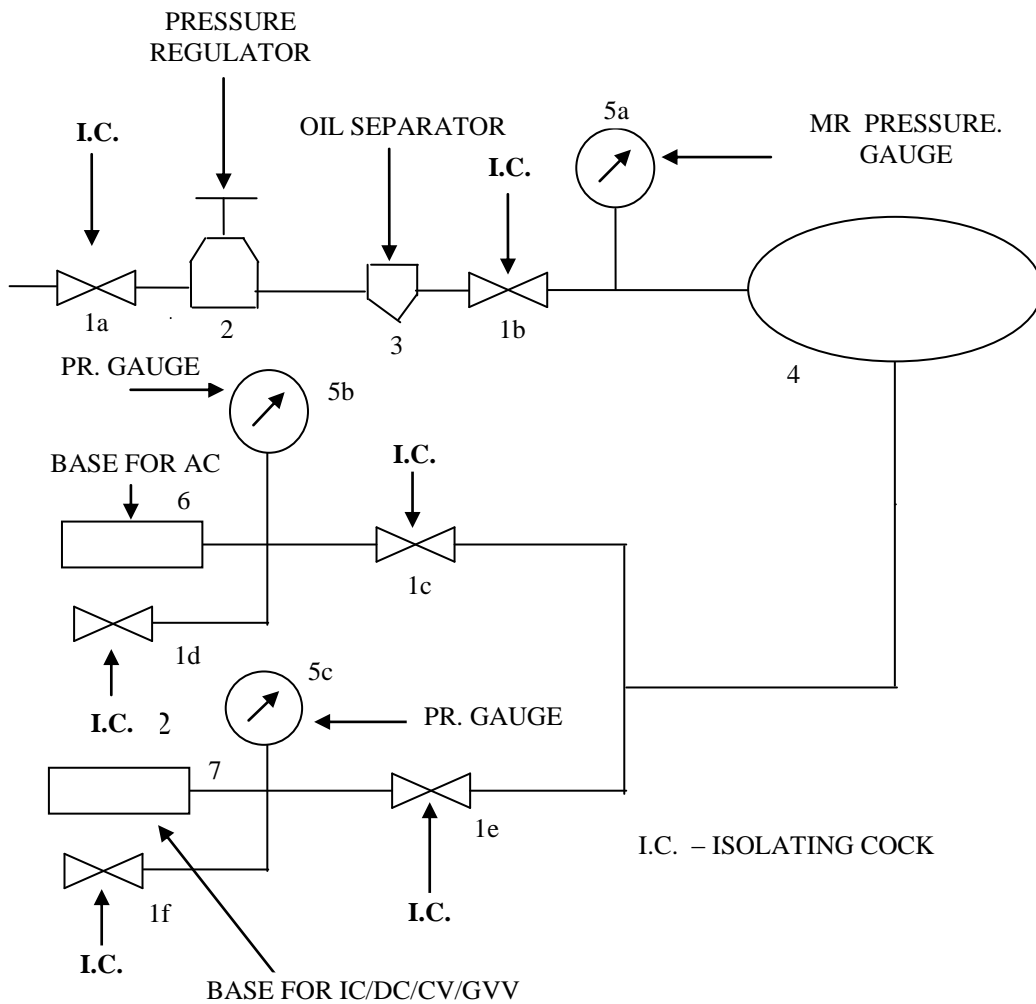
Each dirt collector after overhauling and maintenance should be subjected to pressure test as below:

- i. Mount the dirt collector on base of the test bench.
- ii. Keep cocks ( 1f), (1c) and 1(e) closed.
- iii. Open cock (1a) and (1b).
- iv. Charge the reservoir (5) to 10 kg/cm<sup>2</sup>.
- v. Close two openings on the dirt collector using dummy flanges.
- vi. Open cock (1e), check the pressure at (6c). It should be equal to 10 kg/sq. cm.
- vii. If not develop pressure up to 10 kg/cm<sup>2</sup> by adjusting pressure regulator(2).
- viii. Close cock ( 1e)
- ix. Check for leak over the body and joints with the help of soap solution, no leak is permitted.
- x. Also check for pressure drop in gauge 6(c)- for 3 minutes
- xi. Pressure in the gauge 6c should be maintained.
- xii. Reduce the pressure in the main reservoir (5) to 5 kg/cm<sup>2</sup> by opening cock (1f) and adjusting the pressure regulator (2).
- xiii. Close cock (1f) as soon as pressure reaches upto 5 kg/cm<sup>2</sup>.
- xiv. Remove the dummy flange from the outlet port (which feeds to the distributor valve).
- xv. Check for free flow of air from the outlet port. (If air is not flowing freely it means that the filter is choked).
- xvi. The pressure will soon exhaust through the outlet port.
- xvii. Remove the dirt collector from the test stand.
- xviii. Report Results.

**H. SAFETY PRECAUTIONS**

- a) The assembled dirt collector should be stored in such a way to prevent the following:
- b) Flange surface should be prevented from damage.
- c) Inlet and outlet port should be plugged with protective caps to prevent the entry of moisture and dirt inside the dirt collector.

- d) Specified tools and fixtures should be used for handling, mounting and removing the dirt collector from the test bench.
- e) The small metal parts like screws, nuts, bolts, washers etc. should be kept in a safe place and replaced in case found defective,



**Fig. 7.10 TEST BENCH FOR ANGLE COCK & DIRT COLLECTOR**

## 710. AUXILIARY RESERVOIR

### A. FUNCTION

Auxiliary reservoir is actually a pressure vessel and its function is to feed dry compressed air to the brake cylinder for application of brakes.

### B. SALIENT FEATURES

The auxiliary reservoir is a cylindrical vessel made of sheet metal. On both the ends of the reservoir, flanges are provided for pipe connection. One end of the auxiliary reservoir is connected to the brake pipe through the distributor valve. Auxiliary reservoir is charged through the brake pipe. The auxiliary reservoir is charged to 5kg/cm<sup>2</sup> pressure, charging from the brake pipe through Distributor valve.

At the bottom of the auxiliary reservoir, drain plug (or drain cock) is provided for draining out the condensate/moisture.

**Note:** The dimension & tolerances of the auxiliary reservoir shall be as indicated in latest revision of RDSO drawing WD-92051-S-01 for 100 lit. Capacity and RDSO drawing number WD-92051-S-02 for 75 lit. capacity.

The auxiliary reservoir is to be completely dismantled and overhauled during POH or if there is some specific trouble.

### C. TOOLS AND EQUIPMENT

- a) Spanner A/F 19x22.
- b) Light hammer

### D. PROCEDURE FOR MAINTENANCE

#### DISMANTLING

- Unscrew the drain plug or drain cock.
- Drain the water accumulated in the tank.

#### CLEANING OF PARTS

- Examine the outer surface for any pitting scales or rusting.
- Clean the exterior of the auxiliary reservoir with a wire brush.
- Pour kerosene oil in to the auxiliary reservoir and roll few times and drain the oil.
- Dry the interior of the reservoir with a jet of air.
- Rinse the reservoir with RUSTO-LINE and then with ESSO-RUST 392 or equivalent.
- Clean the drain plug with a wire brush.
- Auxiliary reservoir shall be painted on the exterior with two coats of zinc chromium primer and two coats of black enamel.

#### REPLACEMENT OF PARTS

- Replace the plug washer.
- Replace the plug if threads are rusted or damaged.
- Replace the reservoir having deep cuts on surface.

**ASSEMBLY**

Assemble the drain plug with washer by screwing it back into its position.

**E. TESTING OF AUXILIARY RESERVOIR****Air Pressure Test**

- Block one side passage of the auxiliary reservoir with dummy flange.
- Admit air pressure from the other side passage at 10 Kg/cm<sup>2</sup>.
- Check the leakage at the weld seams, with soap water solution.
- No leakage is permitted.

**Hydraulic Test**

- With a hydraulic pump, apply a pressure of 16 Kg./cm<sup>2</sup> from one flange end after blocking the opposite end.
- Hold the pressure for 5 minutes.
- Check for the leakage on the external surface of the reservoir by gently tapping on the weld seams with a light hammer.
- No leakage is permitted.
- Drain out the water completely and allow the reservoir to dry, by directing a jet of air.

**F. SAFETY PRECAUTIONS**

- Specified tools and fixtures should be used for assembly and dismantling operations.
- Rubber / leather components should be stored in a safe place away from heat, alcohol & acids. All metal parts like washers should be kept in a safe place.

**711. GUARD'S EMERGENCY BRAKE VALVE**

Guard's emergency brake valve is provided in the guard's compartment. This valve provides a facility to the guard to initiate brake application in case of any emergency.

Guard's emergency brake valve is connected to the brake pipe. This valve is actually placed in the guard's compartment so that in case of an emergency, the guard of the train can communicate to the driver of the train by operating the valve provided in the brake van. When the handle of the guard's emergency brake valve is placed parallel to the pipe, the air from the brake pipe is exhausted to the atmosphere. However, to restrict the excessive drop of air pressure in the brake pipe, a choke of 5mm is provided in this valve. This drop in pressure in the brake pipe can also be observed in the air flow meter provided in the locomotive cabin and finally the driver applies the brakes for stopping the train. The handle of the guard's emergency brake valve has to be reset manually to normal position before the brake pipe pressure is to be recharged.

**A. SALIENT FEATURES**

The guard's emergency brake valve consists of a housing in which a ball is housed. The ball has a through hole similar to the isolating cock. To the ball a handle is fixed at the top. By operating the handle the ball can be rotated along the vertical axis. When the hole in the ball gets aligned with the inlet and the exhaust port the compressed air can pass through the valve. However, for restricting the flow of air a

choke of 5 mm is fitted in the exhaust port for controlling the rate of BP exhaust. In order to have leak proof assembly two rubber seats are also provided in the guard's emergency brake valve

Note: The general design and controlling dimension of guard's emergency valve shall conform to the latest revision of RDSO drawing no SK-73549.

The guard's emergency brake valve should be completely dismantled and overhauled during POH or when there is some specific trouble.

## **B. TOOLS AND FIXTURES FOR MAINTENANCE**

The following tools and fixtures are required for overhauling

- Spanner A/F 19/22.
- Special spanner for removing thread plug.
- Spanner for removing gland.
- Light hammer
- Vice.

## **C. PROCEDURE FOR MAINTENANCE**

### **a) DISMANTLING**

- Hold the valve in the vice.
- Unscrew the nut on the stem and remove the nut and the spring washer.
- Remove the handle.
- Unscrew the gland and pull out the stem from the body.
- Remove the two gland packing on the stems.
- Unscrew the threaded plug from the body using a special spanner.
- Remove the 'O' ring and the ball seat from the body.
- Remove the ball and the second ball seat from the body.

### **b) CLEANING OF PARTS**

- Direct a jet of air on the valve body to remove the dust & dirt.
- Clean the external parts of the valve with wire brush.
- All metal parts shall be washed with kerosene oil and wiped dry.
- Rubber parts shall be washed with soap water solution.
- Steel ball shall be handled carefully to avoid scratch marks or dent.

### **c) REPLACEMENT OF PARTS**

- Replace all the rubber parts such as gland packing and 'O' ring.
- If spindle thread is corroded or damaged, the spindle shall be replaced with a new one.
- If threads on the threaded plug are damaged or corroded badly, the plug shall be replaced with a new one.
- If ball of the valve has dent or scratch marks it should be replaced with a new one.



**d) ASSEMBLY**

- Place seat ring in its position in the bore of the body on one side.
- Apply grease lightly on the ball.
- Fit 'O' rings on the spindle.
- Insert the ball in the bore of the body in such a way that the ball sits on the seat ring and the groove seat for spindle is in top position.
- Insert the spindle with 'O' rings such that the spindle enters in to the groove.
- Screw the gland in to the body.
- Insert the second seat ring through the bore of the housing.
- Fit 'O' ring on the threaded plug. With a special tool screw the threaded plug.
- Screw the threaded plug along with the 'O' ring into the housing till the ball seat touches the ball.
- The handle shall be put on the spindle and tightened with spring washer and nut.

**D. TESTING OF GUARD'S EMERGENCY BRAKE VALVE**

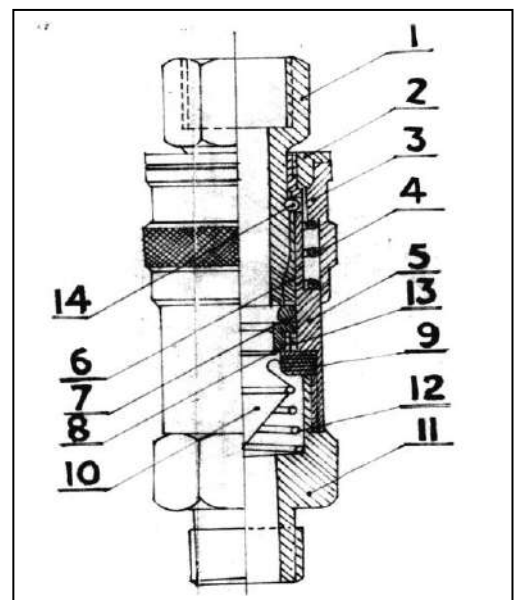
- After overhauling, fix the valve to the test bench.
- Put the handle of the valve in off position (close position).
- Charge the inlet port with a pressure of 10Kg./cm<sup>2</sup>.
- Check for leakage on the spindle portion and on the exhaust port with soap water solution.
- No leakage is permitted.
- Operate guard's emergency brake valve, by putting the handle in open position. Air should escape through the vent of the valve.

**E. QUICK COUPLING ARRANGEMENT**

For fitment of gauge an arrangement for quick coupling is provided. The figure shows the arrangement. The quick coupling when assembled with and without plug shall be leak-proof when tested upto 10 kg/cm<sup>2</sup> air pressure.

*Details of part nos are as under;*

1. Plug	8. Valve
2. Locking nut	9. Valve Seat
3. Locking Ring	10. Valve
4. Spring	11. Lower Body
5. Body Top	12. Spring
6. Locking Bush	13. Spring
7. Seal	14. Ball 3.5 Φ



## 712. SLACK ADJUSTER

### A. SALIENT FEATURES

Slack adjuster (also known as brake regulator) is a device provided in the brake rigging for automatic adjustment of clearance/slack between brake blocks and wheel. It is fitted into the brake rigging as a part of mechanical pull rod. The slack adjuster is double acting and rapid working i.e. it quickly adjusts too large or too small clearance to a predetermined value known as 'A' dimension. The slack adjuster maintains this 'A' dimension throughout its operation. The slack adjuster, type IRSA-600 & IRSA - 750 used on wagons is composed of the following parts

- Adjuster spindle with screw thread of quick pitch (non self locking)
- Traction unit containing adjuster nut, adjuster tube and adjuster ear etc.
- Leader nut unit containing leader nut and barrel etc.
- Control rod with head.

The out standing features of slack adjuster IRSA-600 & IRSA - 750 are:

#### (I) Fully Automatic

Once initially set, no manual adjustment is further necessary at any time during its operation.

#### (II) Double-Acting

The brake shoe clearance is adjusted to its correct value both ways, either when it has become too large (owing to wear of the brake shoes and wheels) or when it has become too small (e.g. owing to renewal of 'worn out brake blocks').

#### (III) Rapid Working

Correct brake shoe clearance is automatically restored after one or two applications of the brake.

#### Verification

If resistance occurs early in the brake application, caused by heavy brake rigging, e.g. an ice coating on the brake shoes, etc., in such cases the IRSA does not pay out slack immediately, but indexes the amount of slack to be paid out. If the slack really is too small, the IRSA will pay out this indexed slack at the next brake application. Thus false pay-out will not occur.

#### True Slack Adjuster

The slack adjuster adjusts incorrect slack only, thus giving the brake its best possible pre-adjusted limit of piston strokes, ensuring a smooth and efficient braking force at all times.

#### Shock Resistant

Train shocks will not cause false take-up or pay-out of slack. When brakes are released, the moving parts of the slack adjuster are securely locked.

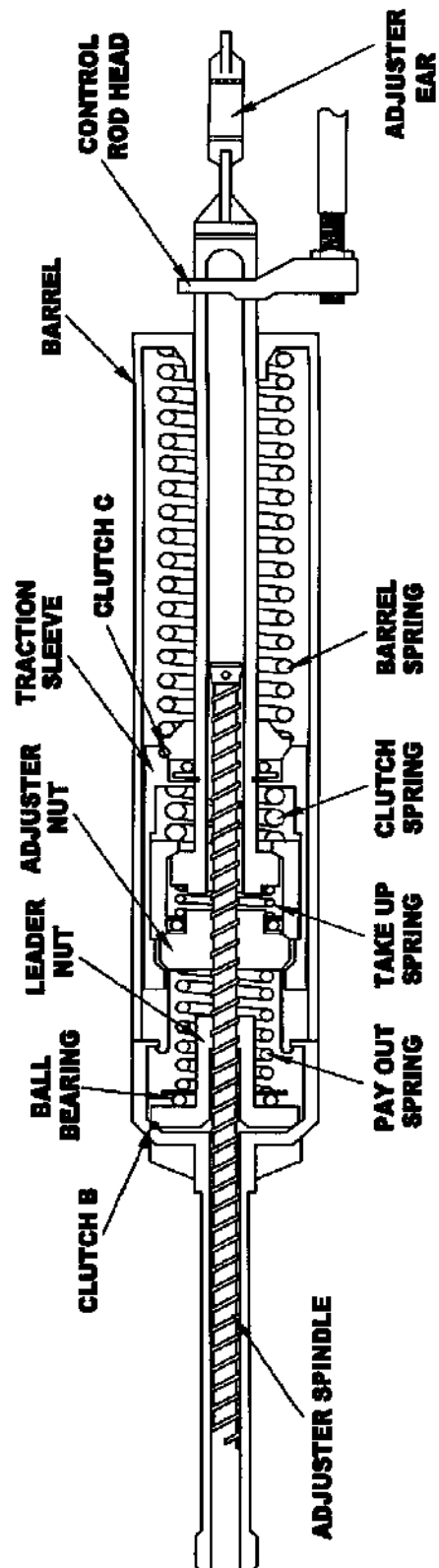


Fig. 7.11 SLACK ADJUSTER

## B. WORKING PRINCIPLE OF SLACK ADJUSTER

In slack adjuster the 'A' dimension is the controlling feature. 'A' dimension is the distance measured between the control rod head and the barrel when the brakes are fully released. In other words 'A' dimension corresponds to the correct slack when brakes are fully released. For wagons it defers wagon to wagon and 'e' dimension which is the limit of length that adjuster will adjust is 555 – 575 mm other than higher axle load wagons ('A' and 'e' dimension should be maintained under all working conditions). For effective operation, slack adjuster has to operate under three different conditions, i.e. with:-

- Correct slack
- Too large slack
- Too small slack.

### a) CORRECT SLACK

If slack is correct then under normal released position, control rod head is at a distance 'A' from barrel end which corresponds to the correct slack (Refer fig. 1).

**For light brake application:** During the first part of brake application, adjuster ear traverses distance 'A'. With correct slack, the brake shoes start applying against the wheel at the same time when control rod head touches the end of the barrel. (Refer fig. 2). Because of the braking action the left sleeve in traction sleeve is drawn against adjuster nut, against the force of barrel spring. This action compresses the clutch spring and clutch C is disengaged.

**For full brake application** the brake is more heavily applied. During this action all parts of the brake rigging will be submitted to proportionate stress and will develop elasticity. As a result the ear end will travel an additional distance 'e' corresponding to elasticity/full brake force (Refer Fig. 3). However the barrel is held back against the control rod head. Thus traction unit is drawn longitudinally through the barrel thereby compressing the barrel spring. Also it tries to take leader nut unit along in the movement. This action releases clutch B. The movement of adjuster spindle through leader nut causes leader nut to rotate on the spindle.

**For releasing the brakes** (Refer Fig. 4)- When pressure in the brake cylinder decreases, the brake cylinder piston and the brake rigging moves back. The traction unit then moves to the left through barrel. As still the clutch spring is compressed the clutch C will remain in open position. The leader nut now gets locked by clutch B and will again begin to rotate on the thread. This time the rotation is in opposite direction, as spindle moves to left. However clutch B is not able to stop this rotation because entire barrel and barrel spring is free to rotate as long as clutch C is held open. Thus barrel and barrel spring rotate with leader nut and during this rotation, barrel spring extends and keeps the end of barrel in contact with control rod head.

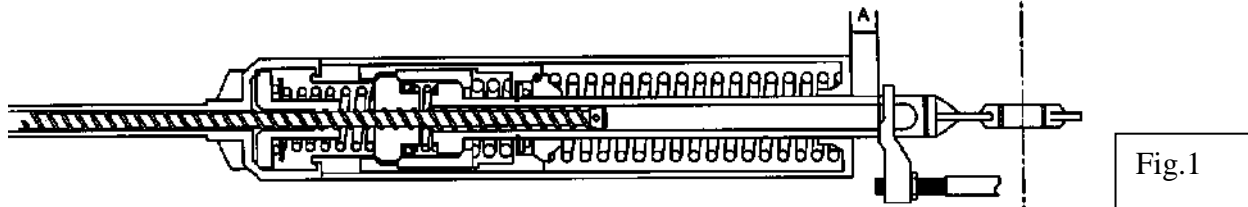


Fig. 1

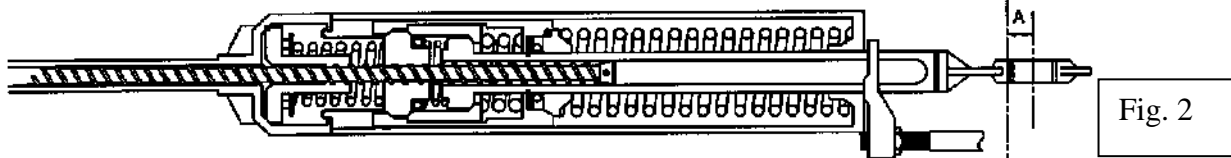


Fig. 2

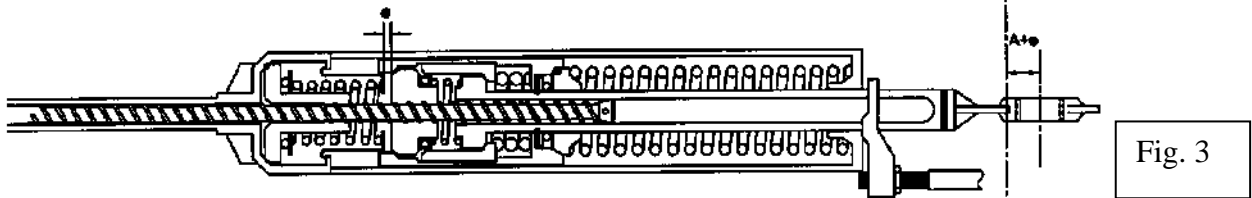


Fig. 3

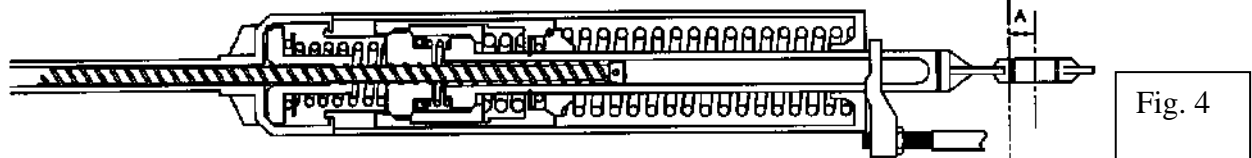


Fig. 4

As long as clutch C is open adjuster nut is kept firmly locked in place on adjuster spindle. Any cycles of brake will cause a correspondingly idle rotation of leader nut unit back and forth on spindle thread. The idling of leader nut prevents all movements from influencing the adjustment. Thus adjustment is governed only by the amount of slack present in the brake rigging.

**For full brake release**, the effective pressure in brake cylinder gets totally released. Also as braking stress disappears, clutch spring locks clutch C. As a result further rotation of barrel and leader nut gets stopped. If the slack is correct, the locking of clutch C takes place at the same moment as distance 'e' is consumed. Adjuster nut is

then momentarily arrested and adjuster ear, adjuster tube and traction sleeve continues to move to left so that sleeve pushes against adjuster nut and locks it. Thereupon whole assembly moves to left until brake is fully released and distance A is restored. (Refer Fig. 1)

Even in emergency application no adjustment takes place. The only difference is that the idle movement of leader nut back and forth will be somewhat longer. This is due to greater deflection of brake rigging under heavier stresses and longer piston travel.

#### b) **TOO LARGE SLACK**

**In released position** there is no difference from release position with correct slack (Refer Fig. 5).

**Now during first stage of brake application** as the brake cylinder piston is pushed out the force is transmitted through the horizontal lever to pull the adjuster ear to the right until a distance 'A' is traversed. At this point the end of the barrel touches control rod head. When this happens, barrel is arrested and also momentarily adjuster spindle with adjuster nut and leader nut is arrested. The left-hand seat in traction sleeve is then immediately drawn against adjuster nut thereby locking it in place on adjuster spindle (Refer fig. 6).

**For full brake application** as slack is too large, brake shoes not yet contacted the wheel. Thus adjuster ear is drawn further to right to a distance 'l' (Refer Fig. 7) pulling adjuster tube, traction sleeve, adjuster nut and adjuster spindle under compression of barrel spring against control rod head. Leader nut is being retained by spring and ball bearing in leader nut unit now starts rotating as adjuster spindle is drawn through it. When brake shoes starts contacting the wheels braking stress starts developing as a result clutch spring is compressed and clutch C is disengaged.

**For releasing the brake** (Refer Fig. 8) take up action. When brake release starts there is an idle rotation of leader nut unit together with barrel and barrel spring in opposite direction as brake rigging moves back and braking stress decreases. As braking stress disappears and clutch C locks stopping further rotation of barrel and leader nut. The movement of adjuster spindle to the left stops. Adjuster ear, adjuster tube and traction sleeve continue to the left, adjuster nut is also being pushed along to the left by take up spring acting on ball bearing. This movement of adjuster nut to left over the spindle (under rotation on the spindle threads) continues until adjuster nut abuts the sleeve of spring in leader nut unit, which is held stationary by barrel. This permits the right hand seat of traction sleeve to engage adjuster nut and lock it in place on adjuster spindle. After this whole assembly moves as a unit to left. Barrel then moves away from control rod head until brake is fully released and distance A restored.

Thus adjustment 'l' that has taken place by adjuster nut is displaced on adjuster spindle, corresponds exactly to excess of slack that was present in brake rigging.

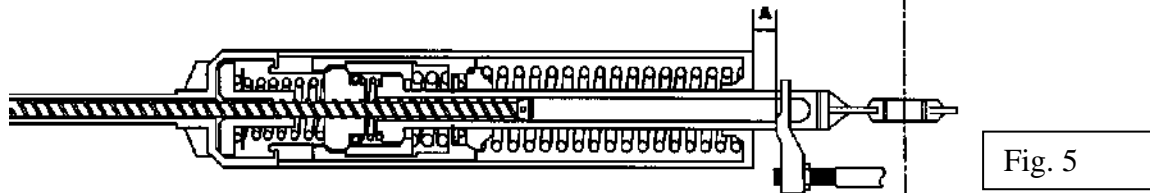


Fig. 5

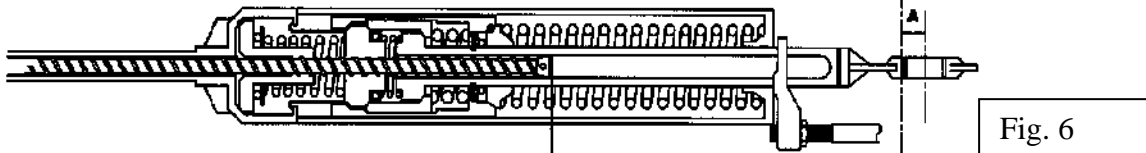


Fig. 6

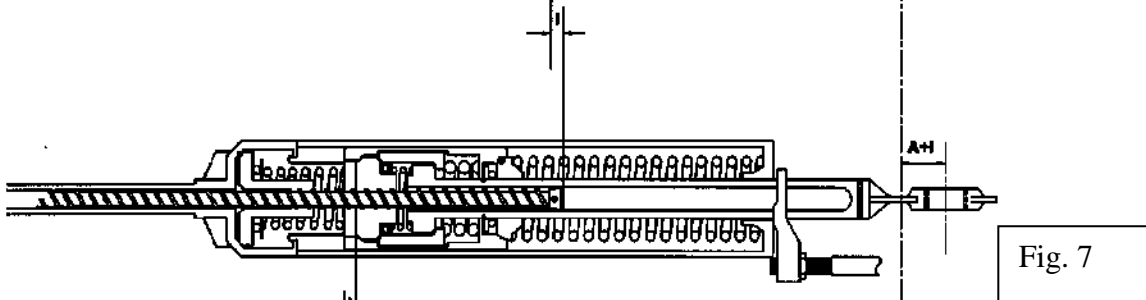


Fig. 7

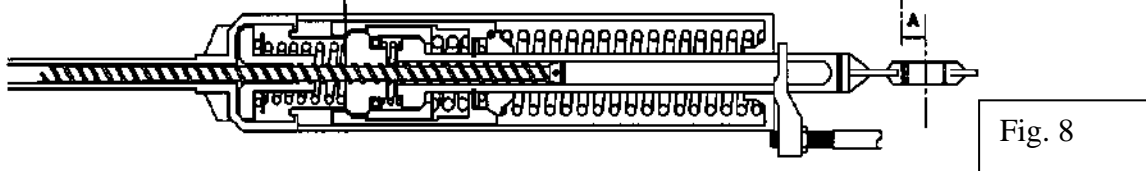


Fig. 8

### c) TOO SMALL SLACK

For released position there is no difference from released position with correct slack.

During **first stage of brake application** (all parts move together to right until) shoes touches the wheels. When this happens, end of barrel has not yet touched the control rod head. There is a distance 'm' between end of barrel and control rod head corresponding to deficiency in slack. The left hand side of traction sleeve is drawn against adjuster nut locking it in place on adjuster spindle. (Refer fig. 9).

**During full brake application, braking** stress builds up and clutch spring is compressed there by clutch C is disengaged. The force of barrel spring now moves barrel, leader nut, barrel spring to the right to contact the control rod head. Due to this displacement the spring in leader nut unit is compressed and the distance 'm' at the end of barrel is transferred to interior of leader nut unit (Refer Fig. 10).

**For releasing the brake** after usual idle movement of leader nut back and forth, braking stress disappear and clutch spring lock the clutch C. The rotation of barrel and leader nut stops and adjuster spindle is held back momentarily, and right hand seat in traction sleeve engages adjuster nut. There upon the whole assembly moves to the left to a distance corresponding to still deficient slack, thus the end of barrel moves away only the distance A-m. The distance 'm' is still indexed in leader nut unit (Refer Fig. 11).

**During next brake application** (Refer Fig. 12) at first stage all parts move together to the right, until further movement of adjuster spindle is stopped by brake shoes contacting the wheel. The end of barrel then very nearly touches control rod head. Barrel is held back on adjuster spindle by the still locked clutch C.

Now **during second stage** of brake application i.e. payout (Refer fig. 13) adjuster ear, adjuster tube and traction sleeve continue their movement to the right. Now the compressed pay out spring expands and pushes adjuster nut on adjuster spindle under rotation on ball bearing so as to follow receding movement of traction sleeve. When distance 'm' is traversed, sleeve of spring in leader nut unit, stop in barrel, and pushing on adjuster nut is ceased. The left hand seat in traction sleeve engages and locks the nut and the brake action is continued. Thus the effective length of slack adjuster is increased exactly by distance 'm' corresponding to the deficiency of slack.

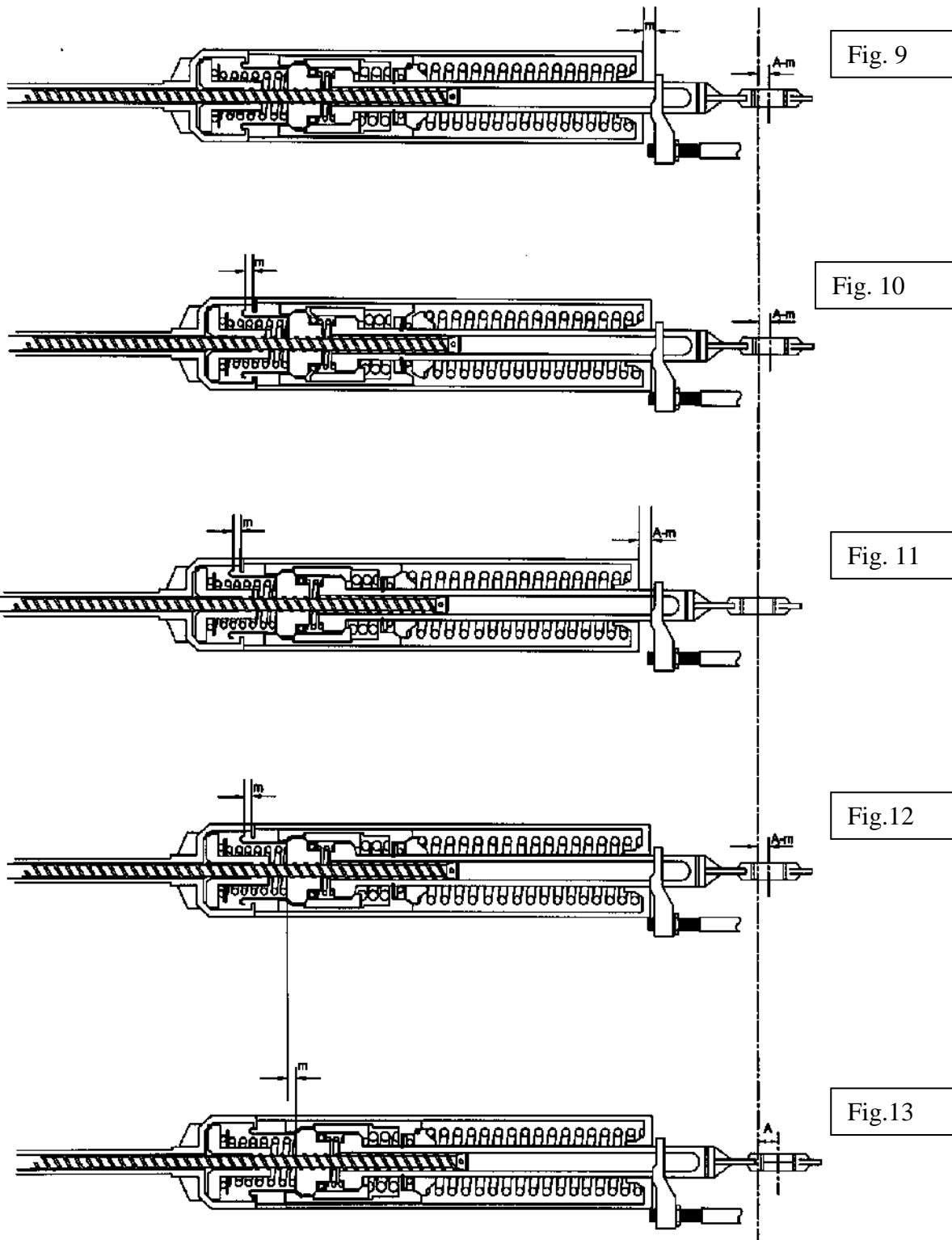
## C. OVERHAULING OF SLACK ADJUSTER

### a) TOOLS & EQUIPMENT

*The following tools and fixture are required for overhauling of slack adjuster;*

- (i) Jacking tool – for mass repair / overhauling of Slack Adjuster pneumatically operated fixture is used.
- (ii) Special Spanner
- (iii) Straight Nose plier (external) (spring type) 18 mm to 25 mm-external
- (iv) Bend nose plier (internal) 25-30mm –internal
- (v) Screw driver
- (vi) Pipe vice & simple 6" vice
- (vii) Open end spanner 11-13 mm.
- (viii) Hand punches
- (ix) Kerosene oil bath
- (x) Air jet gun
- (xi) Slack Adjuster test bench





#### b) PROCEDURE FOR MAINTENANCE

The slack adjuster shall be overhauled at the time of POH of rolling stock. While dismantling or assembling it is essential to use special tools. Each component of slack adjuster shall be examined. Worn out part shall be checked according to the limits. *For details, refer RDSO Technical pamphlet no. G-92 (September-98).*

- I. The minimum desired characteristic of each spring should be taken as under [Ref: RDSO Technical pamphlet No. G-92 (*September - 98*)]:

Sr. No.	Desc. Of spring	Part No.	Spring length compressed	Corrosp. Min. permissible force
1.	Barrel spring	21	475 mm	143 Kg.
2.	Pay out spring	11	100 mm	58 Kg.
3.	Take out spring	37	21.5 mm	22 Kg.
4.	Clutch spring	39	38 mm	300 Kg.

Any spring, which does not conform to the above characteristic, should not be used. In addition any of the springs is badly rusted or having compressed coil turns should not be used.

- II. The following parts must be replaced during POH of the slack adjuster [Ref: RDSO Technical pamphlet No. G-92 (*September - 98*)];

- Spring dowel sleeve part No. (18)
- Lock washer part No. (27)
- Seal ring part No. (2)
- Seal ring part No. (43)
- Rubber gasket part No. (4)
- Spring dowel sleeve part No. (25)
- Dog pin part No. (6)
- Tab washer part No. (34)

#### D. LUBRICATION

After cleaning and inspection all parts of slack adjuster should be coated with semi-fluid grease SERVOGEM-RR3 or BALMEROL multi grease LL3 before undertaking re-assembly.

#### E. SAFETY PRECAUTIONS

The following safety precautions should be observed during overhauling of slack adjuster.

- i. The place of overhauling must be clean and free from dust.
- ii. Ensure that no foreign matter/particle remain inside the sub-assemblies during re-assembly.
- iii. All rubber gasket, seal ring, washers must be replaced during overhaul.
- iv. Specified tools and fixtures to be used for disassembly and assembly operations.

## F. TESTING OF SLACK ADJUSTER

After overhauling, the testing of slack adjuster is carried out in a test rack (Fig. 7.11) for :- i) Take up test & ii) Pay out test

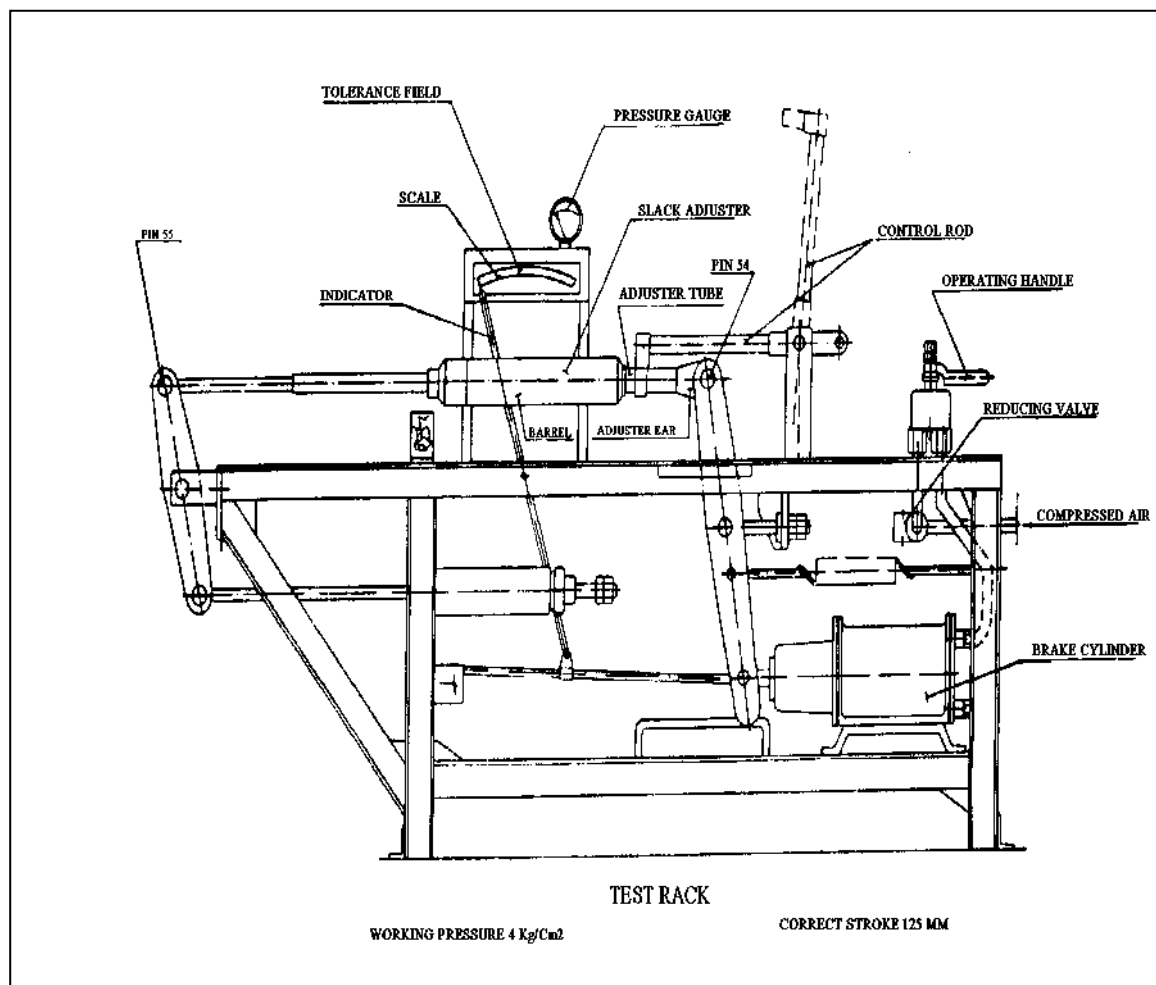
- a) Attach the adjuster ear to the free end of the cylinder lever of the test rack
- b) Screw the test rack spindle into the Slack Adjuster until the entire length of thread is covered by spindle sleeve and attach the free end of the spindle to the test rack.

### I. Take up or Pay-in test

- Let down the control rod, so that the fork of the rod clasps the adjuster tube of the Slack Adjuster
- Apply and release the brake a few times letting the slack adjuster take up until the correct piston stroke is obtained (until the indicator is within  $\pm 5$  mm tolerance field of the scale).

**Note: The Slack Adjuster takes up 100 mm per braking.**

**Dimension A1 will be 98  $\{+1\}$  mm.  
 $\{-4\}$  <sup>2</sup>**



**Fig. 7.12**

**II. Pay-out test**

- Turn up control rod and make two brake applications letting the slack adjuster pay out.

**Note : The slack adjuster pays out max. 30 mm per braking**

- Repeat the above pay in and pay-out tests a couple of times.
- In case the slack adjuster does not accomplish the above mentioned tests satisfactorily, dismantle it and check that the parts are placed correctly.
- The slack adjuster must then be tested once more in the test rack in accordance with the above instruction.
- After the test is finished, remove the spindle from the slack adjuster.
- Remove the slack adjuster from the test rack and unscrew adjuster ear 28.

Give adjuster spindle 23 a final thorough inspection making sure that the threads are liberally greased, and screw it into the Slack Adjuster until its end protrudes from Adjuster tube 41. Put the safety collar 24 and secure it with the spring dowel sleeve. Make sure that the spring dowel sleeve pin fits tightly and that its ends do not protrude above the surface of the collar. Should there be any burrs on the collar, smooth off with a fine file and wipe clean. Then screw the adjuster spindle 23 back into the Slack Adjuster enough to make room for the adjuster ear 28.

Slide control rod head 26 with control rod 44 on to adjuster tube 41. Place lock washer 27 on threaded portion of adjuster ear 28 and screw ear into threaded end of adjuster tube 41.

**Note :** Hold adjuster tube firmly with a pipe wrench. Secure lock washer.27. Install the Slack Adjuster in the brake rigging.

**III. Testing of slack adjuster in brake rigging with hand brake**

In case a test rack is not available in the work shop, a test of function of the slack adjuster ought to be carried out after the slack adjuster is installed in the brake rigging and the correct piston stroke is obtained as follows:-

- Place an iron object e.g. a hammer between the brake block and the wheel tread. Make two brake applications after the second application the correct piston stroke should be obtained.
- Remove the iron object. Make two brake applications. After the first application the piston stroke is too long, but after the second application the correct piston stroke is recorded by the slack adjuster.

**G. PAINTING**

The slack adjuster is given a coat of anticorrosive paint, excluding the adjuster tube 41.

**Note :** The unthreaded portion of the adjuster spindle 23 should not have a thick coating.

**H. PROCEDURE FOR BRAKE RIGGING SETTING AND MEASUREMENT OF “A” AND “e” DIMENSIONS**

The procedure to be adopted for operating brake rigging setting and measuring ‘A’ and ‘e’ dimension is listed below:-

**(I) For 'A' dimension**

- (i) Ensure the air brake is in fully released condition and all the brake rigging gears are in proper condition.
- (ii) Apply brake three to four times to ease the rigging, by dropping and re-charging the air pressure in the brake pipe
- (iii) Ensure once again that brake rigging is in fully released condition.

**If 'A' dimension is not correct**

- (iv) Remove pin securing the control rod in U bracket.
- (v) Detach control rod and rotate it to adjust the gap between barrel end face & control rod head as specified in note above. Secure the control rod in U bracket.
- (vi) Apply brakes two to three times.
- (vii) Check the 'A' dimension using the gauge.
- (viii) Recheck dimension 'A' with brakes fully released after every brake release.
- (ix) Lock the control rod head firmly with check nut and tooth lock washer.
- (x) Secure pin with split pin.

**(II) For 'e' dimension**

- (i) If slack is in excess beyond the capacity of slack adjuster ('e' dimension 555 – 575 mm other than higher axle load wagon) there won't be any slack take up provision in the slack adjuster and slack adjuster will only act as strut/pull rod. This is because of brake shoes and wheel wear reaching their condemning limit/near condemning limit. In such cases the 'e' dimension can be restored by adjusting link provided on the bogie frame head stock.
- (ii) Measure 'e' dimension i.e. distance between protection tube end and mark on adjuster spindle using measuring stick after two or three brake application. It should be set to nearly to its maximum limit i.e. 555 – 575 mm other than higher axle load wagon.

**I. SAFETY PRECAUTIONS**

- i. Always use wedge between wheel and rail before application and release operations for setting and measuring A and e dimension to prevent rolling of wagon
- ii. Ensure no part of the worker's body is in touch with moving brake rigging gears during application and releasing of brakes.
- iii. Do not touch or hold slack adjuster barrel while it is in motion.
- iv. Before setting any dimension ensure wear of brake shoe does not exceed to its minimum permissible worn limit (i.e. thickness of the shoe should not be less than 20mm).
- v. There won't be any slack take up provision in the slack adjuster and slack adjuster will only act as strut/pull rod. This is because of brake shoes and wheel wear reaching their condemning limit/near condemning limit. In such cases the 'e' dimension can be restored by adjusting link provided on the bogie frame head stock.
- vi. Measure 'e' dimension i.e. distance between protection tube end and mark on

adjuster spindle using measuring stick after two or three brake application. It should be set to nearly to its maximum limit i.e. 555 – 575 mm other than higher axle load wagon.

### 713. DISTRIBUTOR VALVE

Distributor valve is the most important functional component of the air brake system and is also sometimes referred to as the heart of the air brake system. The function of the distributor valve is to distribute compressed air received from brake pipe to auxiliary reservoir and control reservoir. In addition to this it also senses drop and rise in brake pipe pressure for brake application and release respectively. It is connected to brake pipe through branch pipe. Various other components connected to the distributor valve are auxiliary reservoir, brake cylinders and control reservoir.

### MANUFACTURERS OF DISTRIBUTOR VALVE

Two designs of distributor valves are in use on wagons. These are:

- i) C3W Type distributor valve
- ii) KE type distributor valve.

Various companies presently manufacturing distributor valves are listed below:

Type	Manufacturers
C3W Type Distributor Valve.	1. Greysham and Co. Delhi
	2. Faiveley Transport India. Hosur
	3. Stone India Ltd. Calcutta.
	4. Greysham international Pvt. Ltd. Noida, U.P.
KE Type Distributor Valve	Escorts Ltd. Faridabad
	Knorr- Bremse Faridabad

A decision has already been taken that new wagons manufactured henceforth will only be fitted either with C3W or KE type distributor valve. Hence the chapter covers description and maintenance of these two types of distributor valves only.

### 714. C3W DISTRIBUTOR VALVE

The C3W Distributor Valve (Fig. 7.14) consists of the following main subassemblies:

- i. Main body
- ii. Quick Service valve
- iii. Main valve
- iv. Limiting device
- v. Double release valve
- vi. Auxiliary reservoir check valve
- vii. Cut off valve
- viii. Application choke
- ix. Release choke.

## **A. FUNCTION OF DISTRIBUTOR VALVE**

For application and release of brakes the brake pipe pressure has to be reduced and increased respectively with the help of driver's brake valve. During these operations the distributor valve mainly performs the following function.

- (i) Charges the air brake system to regime pressure during normal running condition.
- (ii) Helps in graduated brake application, when pressure in brake pipe is reduced in steps.
- (iii) Helps in graduated brake release, when pressure in brake pipe is increased in steps.
- (iv) Quickly propagates reduction of pressure in brake pipe throughout the length of the train by arranging additional air pressure reduction locally inside the distributor valve.
- (v) Limits maximum brake cylinder pressure for full service application/emergency application.
- (vi) Controls the time for brake application and brake release depending on service conditions
- (vii) Facilitates complete discharge of air from the air brake system manually with the help of operating lever.
- (viii) Protects overcharging of control reservoir when the brake pipe pressure is quickly increased for releasing the brakes.

## **B. WORKING OF C3W DISTRIBUTOR VALVE**

The distributor valve distributes the compressed air received from brake pipe to charge control reservoir through cut off valve and auxiliary reservoir through auxiliary reservoir check valve. After charging control reservoir and auxiliary reservoir, when brake pipe pressure is reduced by driver's brake valve, pressure differential acts across the large diaphragm of hollow stem assembly. As a result, the hollow stem gets lifted, opening the check valve of main valve. This action allows auxiliary reservoir pressure to enter into brake cylinder via limiting device for brake application. Main valve together with the limiting device limits brake cylinder pressure to rise to a maximum pressure of  $3.8 \pm 0.1 \text{ Kg/cm}^2$ . As the brake cylinder pressure increases it starts acting on top of upper diaphragm of main valve. This results in downward movement of the main valve along with check valve till it reaches lap position. At this stage the check valve of main valve gets closed, stopping further rise of brake cylinder pressure.

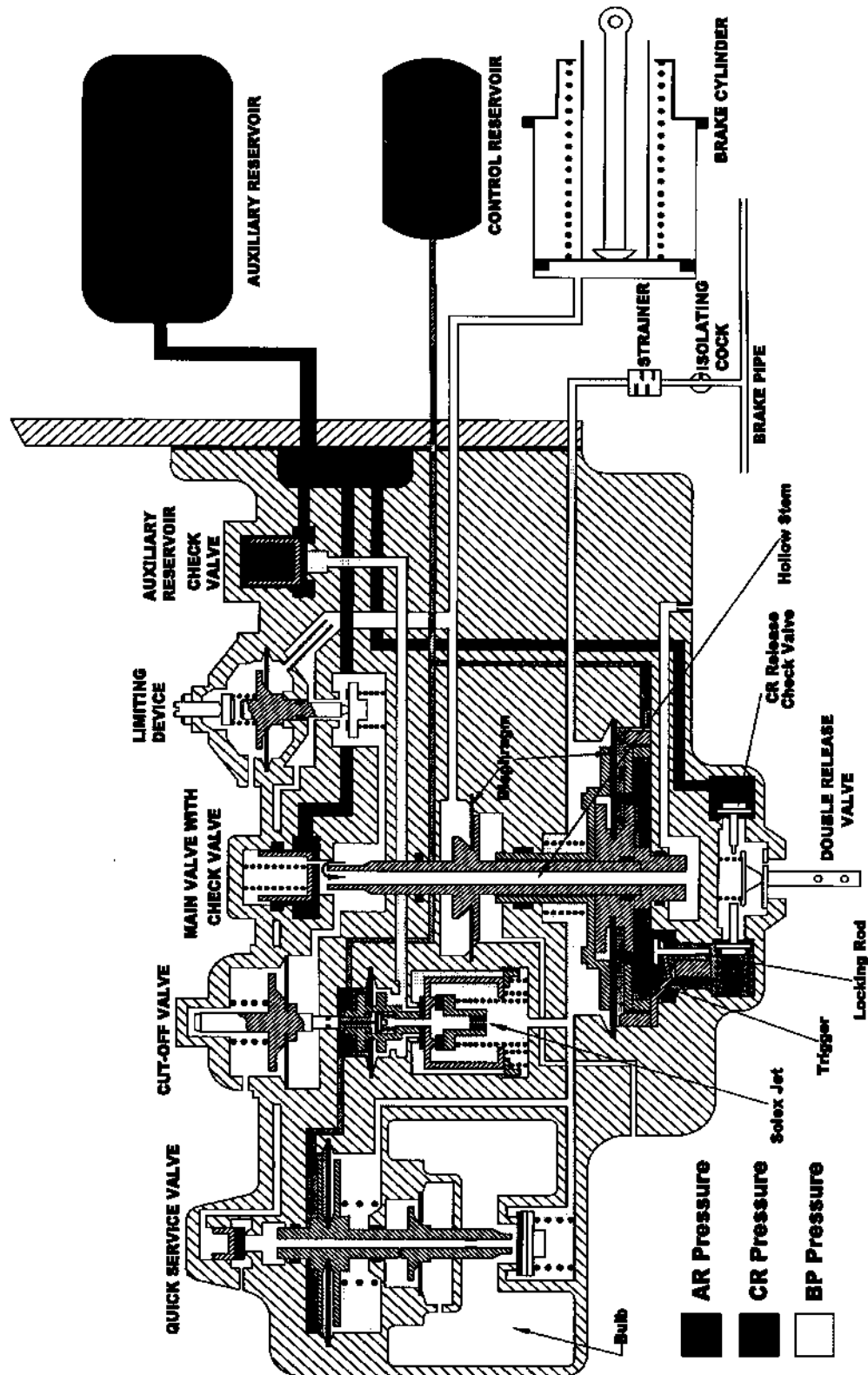


Fig. 7.13 C3W DISTRIBUTOR VALVE



In this position, no further pressure can enter or exit from the brake cylinder. Every time brake pipe pressure is reduced gradually in steps, this phenomenon gets repeated thereby increasing the brake cylinder pressure finally to  $3.8 \pm 0.1 \text{ Kg/cm}^2$ .

For releasing the brakes, brake pipe pressure is increased by drivers brake valve and the hollow stem assembly of main valve is brought to normal position by neutralizing the pressure differential across main valve large diaphragm. At this stage hollow stem gives way at its top to exhaust the brake cylinder pressure to atmosphere.

However, if brake pipe pressure cannot be increased then for releasing the brakes the pressure of control reservoir acting on large diaphragm of main valve has to be reduced. This can be achieved by tilting the release lever of double release valve. Tilting action opens the control reservoir release check valve thereby allowing control reservoir pressure to vent out & simultaneously hollow stem is pulled down which gives passage to brake cylinder pressure to exhaust to atmosphere resulting in brake release.

## C. DESCRIPTION OF VARIOUS COMPONENTS AND SUB-ASSEMBLIES

### (a) MAIN VALVE

The main valve is housed in the main body. The various parts alongwith part numbers (as per manufacturer's catalogue) are shown in Fig. 7.14.

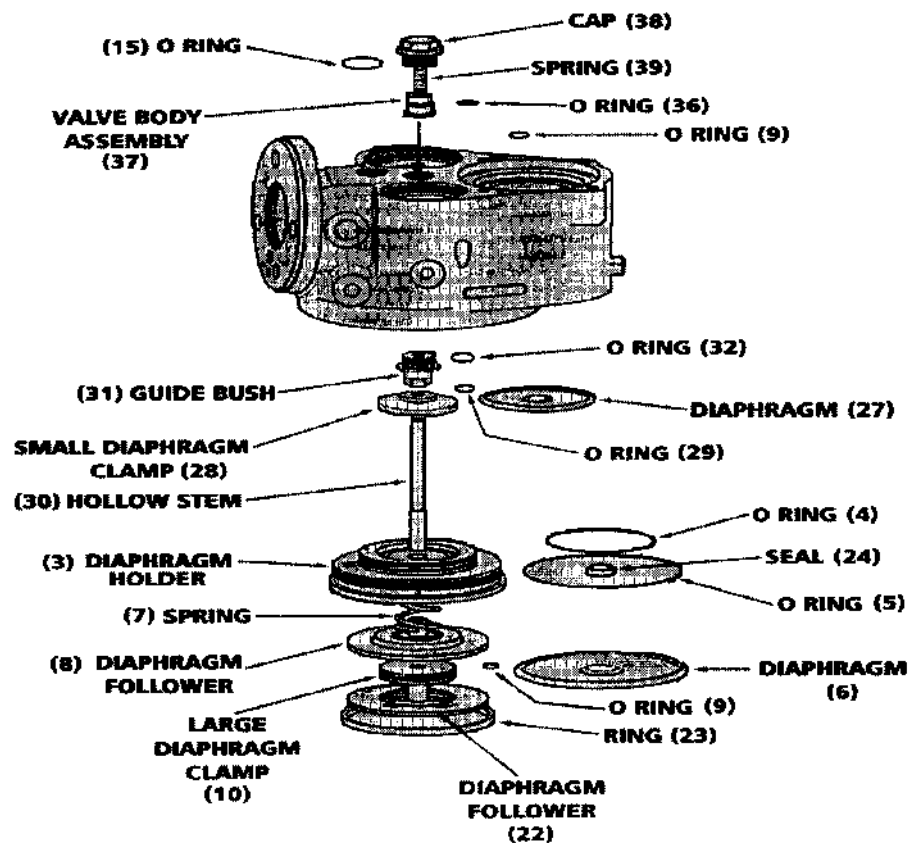
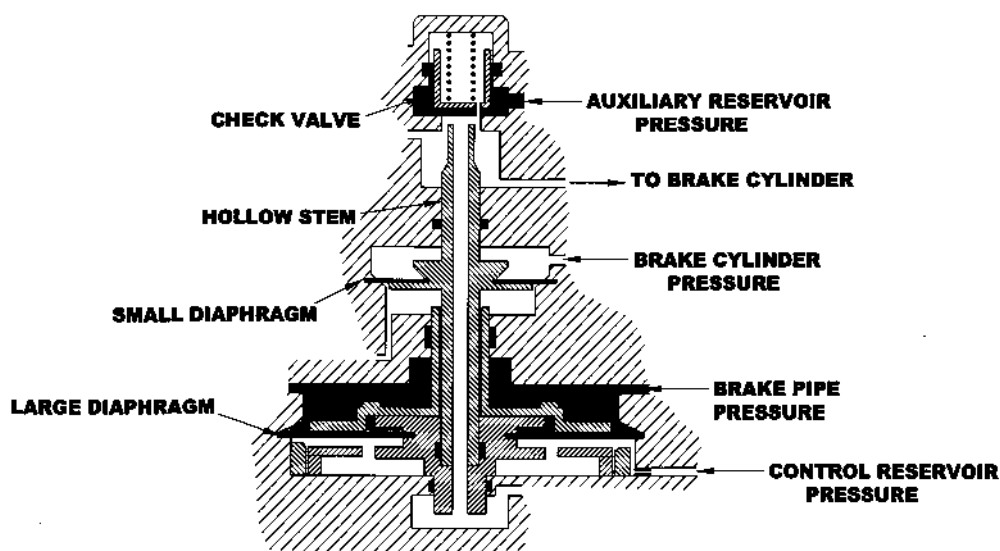


Fig. 7.14 MAIN VALVE



**Fig. 7.15 SECTIONAL VIEW OF MAIN VALVE**

The main valve consists of two diaphragms i.e. large and small. The top face of the large diaphragm, which is situated at the lower position of the stem assembly, is subjected to brake pipe pressure whereas the bottom face is subjected to control reservoir pressure. The small diaphragm is situated at the upper position of the stem. The top face of small diaphragm is subjected to brake cylinder pressure and bottom face to atmosphere. At the top of hollow stem the check valve is situated which controls connection of auxiliary reservoir and brake cylinder. The main valve is also sometimes referred to as three pressure valve. Fig. 7.14 shows various parts of the main valve. The function of main valve is to supply requisite amount of pressure into the brake cylinder when BP pressure is reduced. Also it provides passage for brake cylinder pressure to exhaust to atmosphere, when brake pipe pressure is raised.

#### **(b) CUT OFF VALVE**

The cut off valve is housed in the main body and it consists of the following items:

- Solex jet
- Valve retainer.
- Diaphragm.
- Diaphragm follower.
- Internal circlips.
- Springs.
- Pusher pin.
- Jet valve assembly
- Valve assembly
- Diaphragm clamp
- 'O' rings.
- Body
- Guides etc.

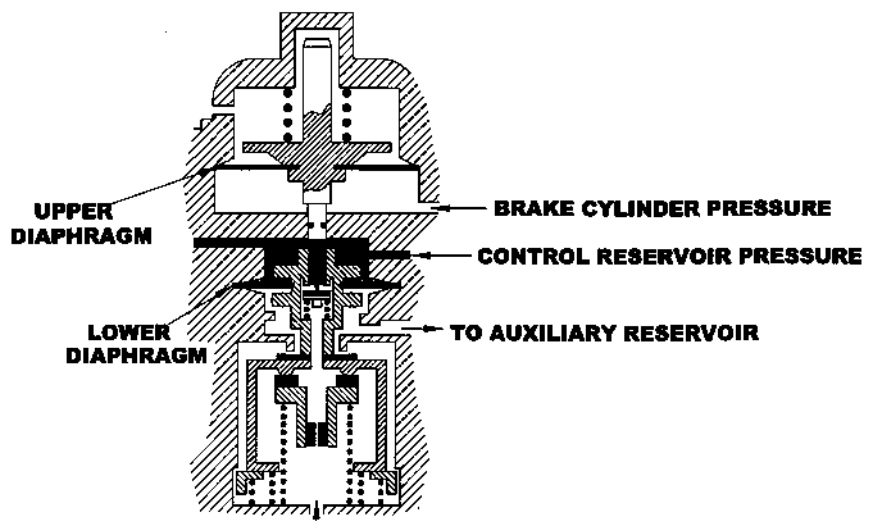
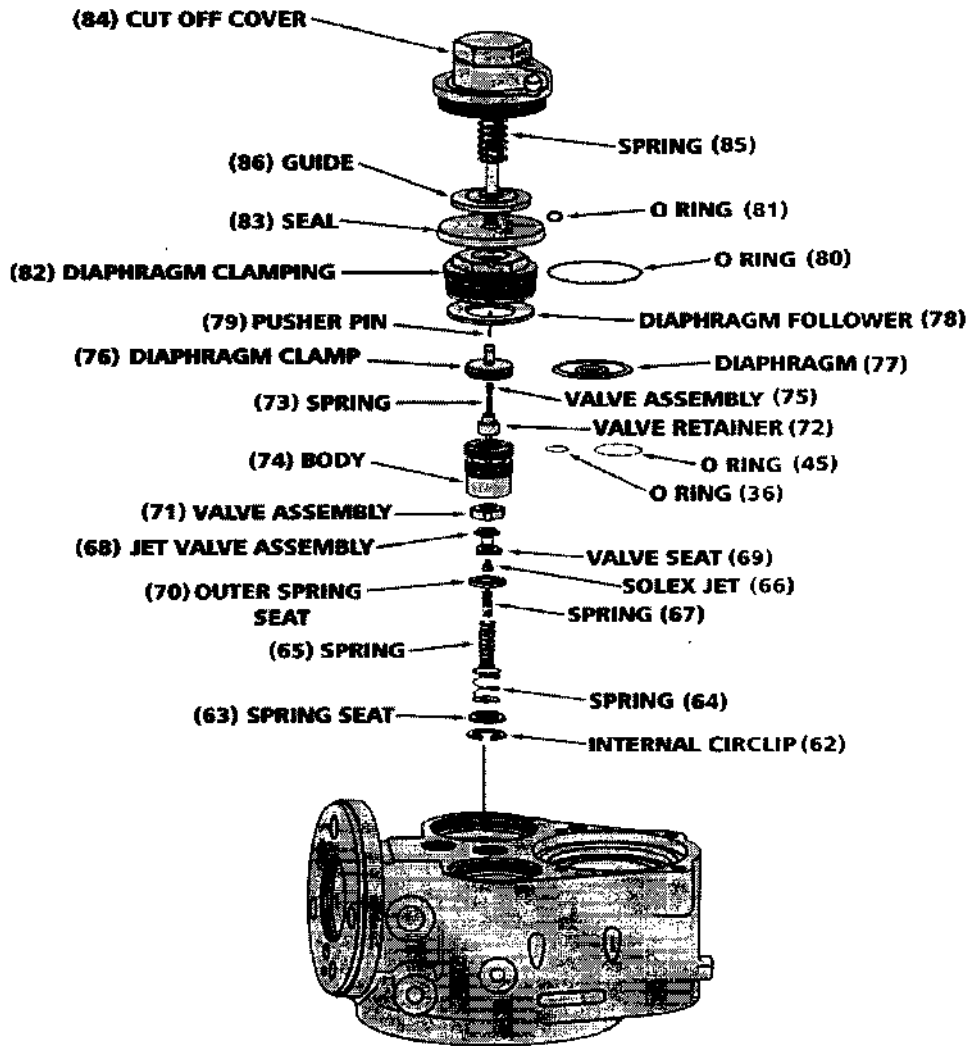


Fig. 7.16 CUT OFF VALVE

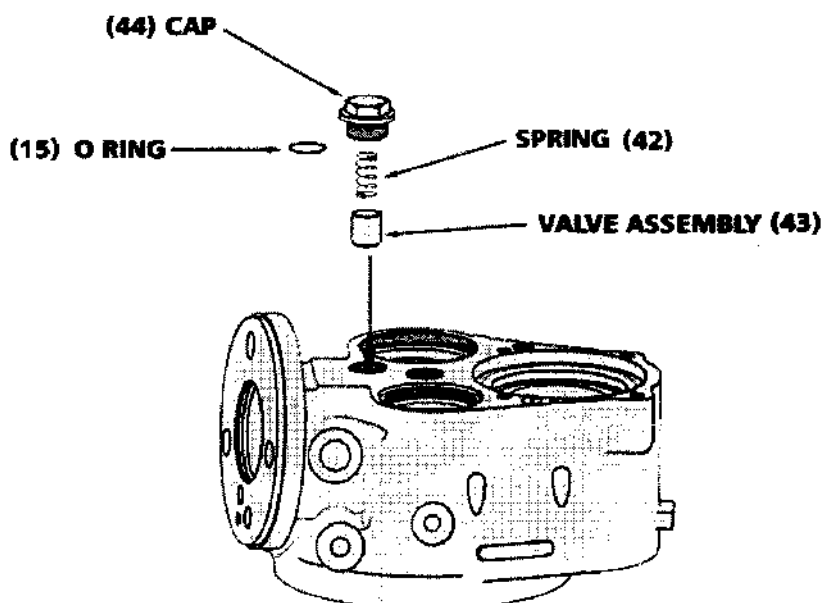
The cut off valve has two diaphragms, upper and lower. The top face of lower diaphragm is subjected to control reservoir pressure and the bottom face to the brake pipe pressure. The bottom face of upper diaphragm is subjected to brake cylinder pressure, and the top face is subjected to atmosphere and compressed spring pressure.

The cut off valve connects the brake pipe to control reservoir during charging and cuts off the connection with control reservoir when brake pipe pressure is dropped for application of brakes. This valve also provides a way to BP pressure from its chamber to auxiliary reservoir check valve.

### (c) AUXILIARY RESERVOIR CHECK VALVE

The auxiliary reservoir check valve is housed in the main body. It consists of the following items.

- Cap
- Valve assembly
- Spring
- 'O' ring



**Fig. 7.17 CHECK VALVE**

Auxiliary Reservoir Check Valve helps in charging the auxiliary reservoir. In addition to charging it also checks back flow of auxiliary reservoir pressure when brake pipe pressure is dropped for application of brakes.

### (d) QUICK SERVICE VALVE

The quick service valve is housed in the main body and consists of the following items :

- Diaphragm
- Diaphragm clamp

- Retainer
- Seal Washer
- 'O' rings
- Springs
- Seal
- Cup
- Valve assembly
- Internal circlip
- Socket etc.

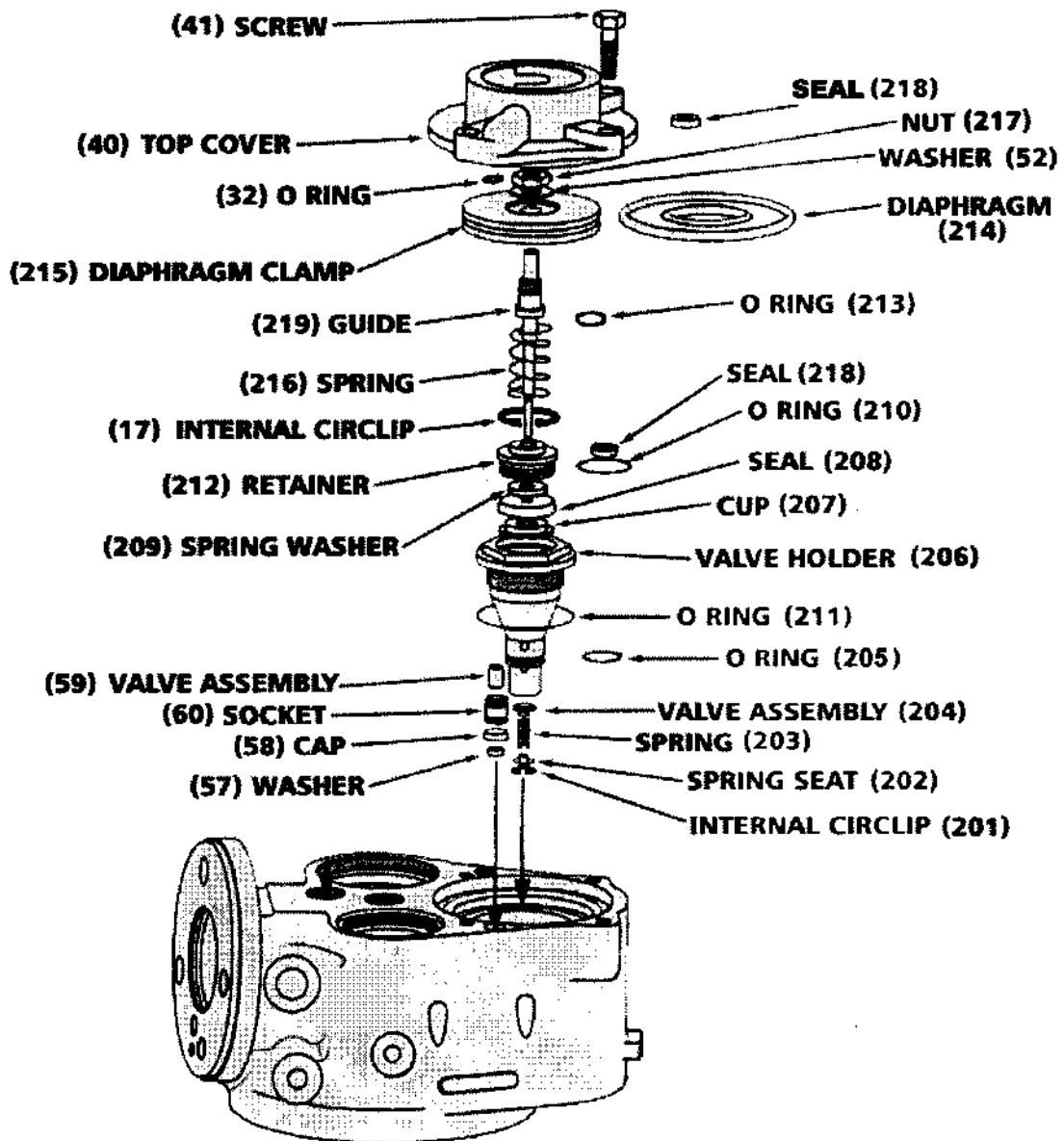
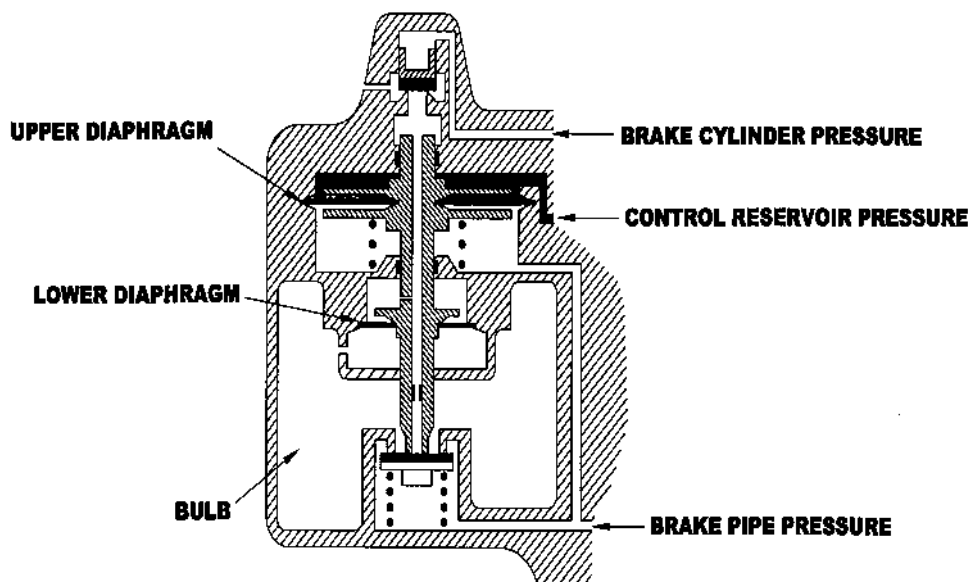


Fig. 7.18 QUICK SERVICE VALVE



**Fig. 7.19 SECTIONAL VIEW OF QUICK SERVICE VALVE**

The quick service valve has two diaphragms i.e. upper and lower. The top face of upper diaphragm is subjected to control reservoir pressure and bottom face to brake pipe pressure. Where as at lower diaphragm, the bottom face is subjected to brake pipe pressure when brakes are applied.

The function of quick service valve is to create an initial pressure drop in brake pipe pressure by allowing a sudden entry of brake pipe pressure into the large volume bulb at the start of brake application. This ensures rapid propagation of pressure reduction in brake pipe through out the length of train.

#### (e) LIMITING DEVICE

The limiting device is housed in the main body and consists of the following items.

- Diaphragm.
- Diaphragm clamp.
- Diaphragm follower.
- Cap.
- Valve retainer.
- Inshot valve assembly.
- Adjusting nut.
- Check Nut.
- Bush with cover.
- ‘O’ rings.

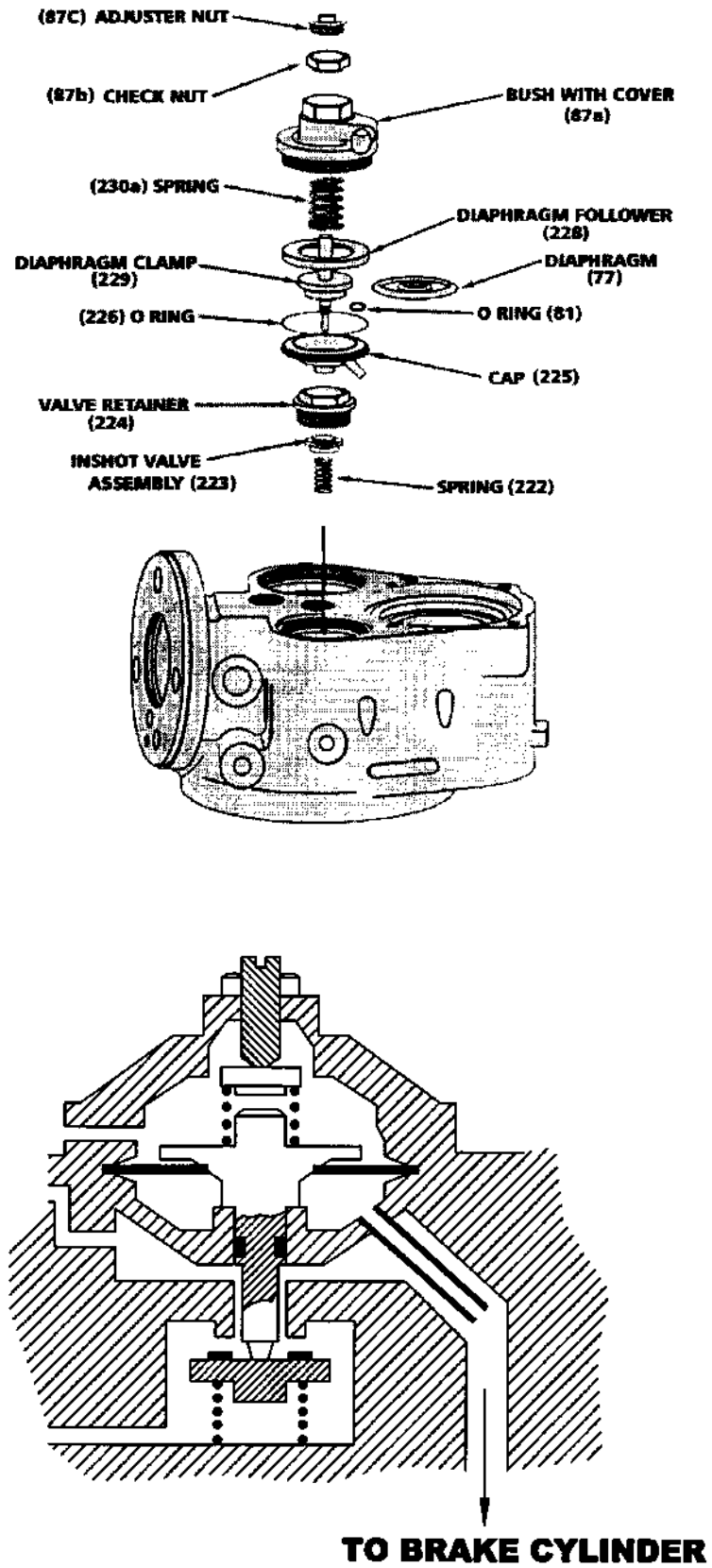


Fig. 7.20 LIMITING DEVICE

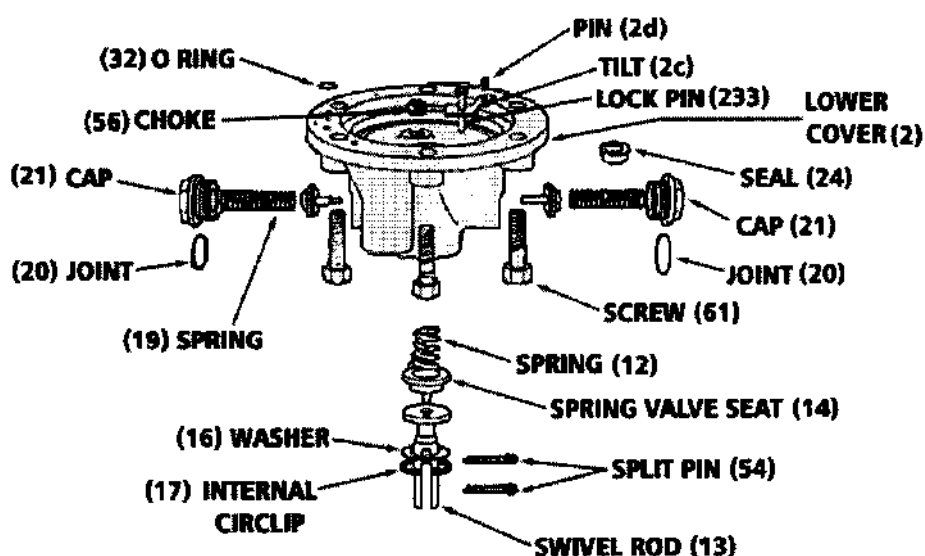
The limiting device has one diaphragm. The bottom face of the diaphragm is subjected to brake cylinder pressure during applied brake condition and top face is under pressure of compressed spring and atmosphere.

The function of limiting device is to restrict the maximum brake cylinder pressure to  $3.8 \pm 0.1 \text{ Kg/cm}^2$  irrespective of the drop in brake pipe pressure or auxiliary reservoir pressure.

**(f) DOUBLE RELEASE VALVE**

The double release valve is housed in the bottom cover and it consists of the following items.

- Tilt
- Pin
- Spring
- Swivel Rod
- Spring valve seat
- Washer
- Circlip
- Cap
- Split pin
- Choke
- Control reservoir release check valve
- Auxiliary reservoir release check valve



**Fig. 7.21 DOUBLE RELEASE VALVE**



The function of double release valve is to release the brakes manually when a single brief pull is given to the lever. However with a continuous pull to the release lever it also vents auxiliary reservoir pressure.

#### D. DIFFERENT STAGES IN OPERATION OF C3W DISTRIBUTOR VALVE

For effective functioning of the air brake system, the distributor valve has to operate effectively during :

- a) Charging stage
- b) Application stage and
- c) Release stage

##### (a) CHARGING STAGE

During charging stage the compressed air flows from the brake pipe and enters into the brake pipe chamber of the main valve, cut off valve and quick service valve. Due to this pressure the various valves get activated and perform as under.

**Main Valve:** Due to brake pipe pressure acting on top face of the large diaphragm, differential pressure acts on the main valve. As a result the hollow stem moves downwards there by connecting brake cylinder to atmosphere. In addition, because of BP pressure at the top, large diaphragm presses the ring and trigger. This action unlocks the CR release valve by raising the locking rod upwards.

**Cut Off Valve:** As brake pipe pressure enters into the cut off valve, it flows through the solexjet and valve (which is held open due to action of BP pressure on bottom side of the lower diaphragm) to the control reservoir. As the CR & BP pressure equalises, diaphragm assembly comes down and valve reaches the lap position. The control reservoir pressure now also reaches the upper portion of top diaphragm of quick service valve and the bottom portion of large diaphragm of main valve.

Simultaneously, the auxiliary reservoir is charged with BP pressure reaching from cut off valve chamber via auxiliary reservoir check valve.

##### b) APPLICATION STAGE

During emergency application, the brake pipe pressure is reduced rapidly to 0 kg/cm<sup>2</sup> by the driver's brake valve. Because of this drop, the position of the various valves will be as described below.

**(i) Main valve:** With drop in BP pressure to zero, the differential pressure acts across the large diaphragm. As a result, the hollow stem is moved in upward direction and pushes the check valve thereby opening the passage for entry of auxiliary reservoir pressure at the top portion of main valve. This pressure then gets a way to brake cylinder through limiting device. The brake cylinder thus gets charged with the compressed air. This pressure is known as "BC pressure".

**(ii) Limiting Device:** The auxiliary reservoir pressure which entered into the top position of main valve now enters the limiting device through the valve which is held open. From limiting device air pressure now enters the brake cylinder. When the BC pressure rises to 3.8 kg/cm<sup>2</sup>, the upward force on the diaphragm lifts the guide and the valve at the bottom of the limiting device gets closed. Thus further entry of air into the brake cylinder stops.

When the brake cylinder pressure reaches  $3.8 \text{ kg/cm}^2$ , this pressure i.e. BC pressure acts on :

- Top face of small diaphragm of main valve
- Bottom face of upper diaphragm of cut off valve
- Top (small chamber) of quick service valve

Now because of BC pressure acting at main valve small diaphragm, the hollow stem is pulled down. As a result, the check valve at top comes down to “close” stage and assumes lap position with the hollow stem closing further entry of AR pressure.

**(iii) Cut off valve:** In cut off valve, the bottom face of the upper diaphragm is subjected to BC pressure. As a result, the guide is lifted. Also the upper portion of lower diaphragm is subjected to CR pressure, which pushes the total assembly downwards. This action closes the valve of cut off valve, thereby isolating it from control reservoir pressure.

**(iv) Quick Service Valve:** In quick service valve, BC pressure acts at the top of valve and control reservoir pressure acts at the top face of upper diaphragm. As a result, the stem is pushed down and the valve at the bottom gets opened. Now as the BP pressure inside DV is at zero, the residual BP pressure from the bulb of quick service valve will flow back and vent to the atmosphere.

#### **(v) GRADUATED APPLICATION**

During graduated brake application the brake pipe pressure is dropped in steps by driver's brake valve. The movement of various valve assemblies is almost in the same direction as during emergency application, but their movement is comparatively less. In the main valve however after each application the hollow stem assumes the lap position with the check valve.

In addition to this during graduated application the bottom valve of limiting device is held open to allow compressed air to enter into brake cylinder.

When BC pressure reaches  $3.8 \text{ kg/cm}^2$  the bottom valve in limiting device gets closed. Similarly at the time of full service application as the BC pressure reaches  $3.8 \pm 0.1 \text{ kg/cm}^2$  within specified time, the position of various valve assemblies will be the same as described above.

#### **(c) RELEASE STAGE**

When the brake pipe pressure is increased in steps for graduated release of brakes, the position of the different valves is as described below.

- (i) Main valve:** At the top face of large diaphragm, as the BP pressure increases, the hollow stem moves downwards leaving its lap position with the check valve. The BC pressure thus finds a passage from top of hollow stem to exhaust to the atmosphere. This action reduces pressure on the top of upper diaphragm and the hollow stem again lifts up to lap position. It closes the hollow stem top portion. The same cycle is repeated when BP is increased during next stages. In this way graduated release effect is obtained.

**(ii) Cut off valve:** As the BP pressure increases the position of cut off valve remains similar as in graduated application i.e. the cut off valve will remain closed, isolating CR pressure from brake pipe pressure.

**(iii) Quick service valve:** When the BP pressure is increased, then as explained above for the main valve, the BC pressure gets exhausted to atmosphere. This action gradually reduces the BC pressure. When BC pressure reduces to  $0.8 \text{ kg/cm}^2$  during brake release, the force at the top of the quick service valve becomes comparatively less than BP pressure present in Quick Service Valve. As a result, the valve at the top gets lifted thereby giving passage to blocked BP pressure to atmosphere. With the exhaust of BP pressure, the Quick Service Valve of the Distributor Valve again gets ready for next brake application.

**(iv) Manual release:** Double release valve provides for accelerated manual brake release, which is particularly useful during shunting operation. A short pull on the lever of double release valve is all that is needed. This action opens the control reservoir release check valve, which is then held open by the locking rod. Venting of control reservoir through the open control reservoir release check valve brings the main valve to release position and exhausts the brake cylinder pressure through the hollow stem.

#### **E. SPECIFICATION OF C3W DISTRIBUTOR VALVE**

The C3W distributor valve is a graduated release type of valve and has been approved by UIC to comply with requirement of its specification no. 540 and 547.

#### **F. PERIODIORITY OF OVERHAULING**

The overhauling of the distributor valve is carried out during POH or when there is some specific problem.

#### **G. MAINTENANCE**

C3W Distributor Valve consists of various sub-assemblies possessing highly finished, accurate and sophisticated small parts and therefore need a well arranged work-shop equipped with standard tools as well as specially designed tools and fixtures. It is also important to state that the work place (DV-overhauling section of the workshop) should be a clean, well organized, dust & dirt free and a properly developed space where the following activities should be adjacently and separately organized:-

- dismantling and cleaning
- assembling and testing
- storage of assembled distributor valve &
- storage of spare parts including POH kits stocking store etc.

The tools and fixtures required for the disassembly and assembly of C3W distributor valve are given in table below.

## H. TOOLS AND FIXTURE FOR C3W DISTRIBUTOR VALVE

Sr.No.	Description
1	Open end spanners of 24-27 mm, 20-22 mm, 17-19 mm & 11-13 mm
2	Socket wrenches of size 13mm, 17mm, 19mm, 22mm, 27mm & 32mm with driving handles – a. Simple L Shaped b. Reversible ratchet and c. Torque calibrated for (1.5 to 6 Kg.m) range
3	Ring spanner (32-36 mm)
4	Allen key (6 mm)
5	Circlip pliers internal & external both (Small & Medium)
6	Plier general design and long nose separately
7	Screw drivers (5 mm and 8 mm blade sizes)
8	Nylon hammer
9	Special tools 1. SCT-6014-pin end tool 2. SCT-6016-pin end tool 3. SCT-6015-‘O’ ring set tool 4. SCT-6017-hollow stem-lead-tool 5. SCT-6026-spetula (bent tool) 6. SCT-6092-socket spanner 7. RPBF-0003-) fixture for holding guide (76) 8. Air jet gun with flexible hose
10	Bench mounted DV - holding fixture

## I. OVERHAULING PROCEDURE

Before opening the distributor valve, it needs to be dusted and cleaned externally. The disassembling and assembling of the distributor valve in the workshop is facilitated by using a bench mounted DV-holding fixture, with facility to rotate through 3600 in the vertical plane and locking it after every 900 rotation.

The distributor valve is mounted on the fixture and can be locked in any desired position. The sub assemblies of different valve are dismantled in the sequence. It is imperative that components of each sub assembly have to be carefully handled and arranged in an identifiable group sequence. For part numbers and name of components of various sub-assemblies / valves, refer to the concerned manufacturer's maintenance manual.

For POH kit, refer RDSO Technical pamphlet No. G-97 (Latest amendment) Annexure XIII.

## 715. TESTING OF DISTRIBUTOR VALVE

For the proper functioning of the Air Brake System, it is necessary to test the Distributor Valve. The following tests are carried out to ensure the proper functioning of Distributor valve:

The following tests are conducted on the distributor valves:

- (i) Pressure tightness test – (during charging, application and release test & emergency application test).
- (ii) Charging time.
- (iii) Full service application and release.
- (iv) Overcharge protection test.
- (v) CR overcharge reduction test
- (vi) Emergency application.
- (vii) Sensitivity test.
- (viii) Quick service test.
- (ix) Insensitivity test.
- (x) Re-feeding test.
- (xi) Graduated application test.
- (xii) Graduated release test.
- (xiii) Quick release test
- (xiv) Control reservoir check valve reset test.

### 715 A. PURPOSE OF CONDUCTING VARIOUS TESTS

#### a) Pressure Tightness Test

Before conducting any other performance test ( to ensure the efficiency of the DV it is advisable to check for the leakage from any part of the DV). For this purpose BP is charged to regime pressure and then DBV is brought to full application, Emergency and release positions respectively, and in each of the above positions DV is tested by soap solution to confirm no leakage. This is done so that every valve of

DV operates at least once and leakage from every part of the DV is checked. If DV is leakage free then it can be said with high probability that its maintenance or overhaul and assembly is carried out properly and generally it should perform as per specifications in other tests also. However, if other tests are conducted before conducting leakage test, and leakage is detected during any test then that leakage is to be attended and tests are to be repeated. Therefore to avoid reworking it is always advisable to test the DV first for leakage and once leakage free operation is assured only then other tests are to be conducted.

However in KE type of valves, it is possible to test subassemblies of the DV also before finally assembling it. In this type of valve, three main assemblies i.e. R-charger with isolating valve, Choke cover & Bottom cover with Quick release valve can be tested for leakage before fully assembling the DV and the chances of leakage from the DV are than highly reduced.

**b) Charging Time**

Charging time for initially charging the control reservoir and auxiliary reservoir up to desired pressure is specified. Operation of the DV should be such that time required to charge the CR and AR should neither be more nor less than the specified limits. It is necessary because if the DV of different wagons operate with different timings, then brakes will be applied and released in different wagons with different timings, and this may create problems.

**c) Full Service Application and Release.**

For efficient operation of brakes, it is necessary that after operating the DBV for applying the brakes, brake cylinder pressure should rise to the desired level, very quickly (i.e. from 0 to 3.6 kg/cm<sup>2</sup> in 18 to 30 seconds). Therefore all the distributor Valves are to be tested for the time required to raise the brake cylinder pressure. This time should neither be more nor less than the specified limits. In this test it is also checked that brake should release quickly and it means that brake cylinder pressure should be released within specified time period, and hence the DV is tested for release timings also. If the brakes of different wagons operate with different speeds then it can prove disastrous and hence this test ensures that speed of operation of various DV are more or less same.

**d) Overcharge Protection**

Sometimes driver overcharges the brake pipe for short duration so that brake pipe is completely charged till last wagon and brakes in every wagon are released quickly.

But this overcharging of brake pipe should not result in overcharging of control reservoir and auxiliary reservoir, because the pressure of control reservoir works as reference pressure for the DV and if the control reservoir is overcharged then it may result in malfunctioning of the DV. And hence the DV should be such that it should avoid overcharging of CR and AR even if brake pipe is slightly overcharged (In this test, brake pipe is charged up to 6 kg/cm<sup>2</sup> for 25 seconds and it is assured that CR and AR should not get overcharged by 0.1 kg/cm<sup>2</sup>.)

**e) CR Overcharge Reduction Test**

Some times when locomotive connected with a rake is changed, in that case there may be problems due to different regime pressures of locomotive and rake. In these type of cases control reservoir is overcharged for short duration for adjustments, but control reservoir pressure should come back to brake pipe pressure when release valve handle of the distributor valve is pulled for 3 seconds.

**f) Emergency Application Test**

The purpose of this test is similar to that of full application and release test i.e. in this test time taken to raise the brake cylinder pressure during emergency application is measured. It is also seen that maximum rise in the brake cylinder pressure is within limits.

**g) Sensitivity Test**

The DV should be sensitive enough to sense the drop in brake pipe pressure quickly and to respond accordingly by raising the brake cylinder pressure so that brakes are applied. Therefore sensitivity test is conducted on DV for checking the fastness of response of DV. In this test it is expected that DV should respond to apply brakes when BP pressure is reduced by 0.6 kg/cm<sup>2</sup> in 6 seconds.

**h) Quick Service Test**

This test is conducted to ensure proper functioning of quick service valve of C3W type DV. While in case of KE type DV it ensures proper functioning of U-controller .

**i) Insensitivity Test**

As explained in the above test, DV should be sensitive enough but at the same time it should not be very sensitive. Since if it is very sensitive, then it may operate even when there is a small leakage from brake pipe i.e. even when there is a small drop in pressure of the brake pipe. Therefore it is expected that DV should be insensitive enough so that it does not operate due to small drop in pressure in brake pipe due to leakage. And hence insensitivity test is conducted On DV and it is assured that it should not operate if brake pipe pressure is reducing @ of  $0.3 \text{ kg/cm}^2$  in 60 seconds.

**j) Re-feeding Test**

If brakes are in applied position and brake cylinder starts leaking due to some problem then brake cylinder pressure may drop and it may result in releasing of brakes, which may prove disastrous. Therefore the DV is designed in such a way that it continues to supply air to the brake cylinder so that the brake cylinder pressure is maintained at desired level, even when it is leaking. The re-feeding test assures the proper functioning of main valve in case of C3W type DV and three pressure valve in case of KE type DV.

**k) Graduated Application Test**

This test is conducted to prove that brakes can be applied gradually or slowly. This test ensures response of the distributor valve when brake pipe pressure is gradually reduced i.e. brake cylinder pressure should increase accordingly when brake pipe pressure is reduced gradually.

**l) Graduated Release Test**

Similarly air brake system should be such that brakes can be released gradually or slowly. To ensure this in this test, brake pipe pressure is increased in steps and it is seen that brake cylinder pressure should reduce accordingly.

**m) Quick Release Test**

This test is also known as automatic exhausting of brake cylinder. When a wagon is disconnected from the rake, its brake pipe pressure becomes zero. In this condition, brakes of the wagon will be automatically in applied position. To release the brakes a manual handle is provided on the DV. When this handle is pulled, it results in complete draining of AR and CR and brake cylinder, and in other words, the brakes are released.

But at the same time on pulling this lever when brakes are in released position (i.e. when brake pipe is in charged condition) it should not result in releasing of CR & AR. Similarly when brakes are in applied condition and if some one pulls the release lever even then ideally brake cylinder pressure should not exhaust. But DV design is such that in this condition brake cylinder pressure exhausts to some extent but it should not exhaust beyond  $1 \text{ kg/cm}^2$  i.e. even after pulling release lever when brakes are in applied position, the brake cylinder pressure should not fall below  $1 \text{ kg/cm}^2$ .

This test ensures proper functioning of the DV when release lever is pulled.

**n) CR Check Valve Reset Test**

This test is also known as “automatic repositioning of quick release system”. If brake pipe pressure is again increased in the above test (CR is in discharged condition) by pulling the release lever in emergency operation or detached wagon condition ( i.e. when brake pipe pressure is zero), double release valve (which is responsible for discharging the control reservoir) should close automatically so that CR is again charged.

**715 B. TOOLS AND EQUIPMENT FOR TESTING**

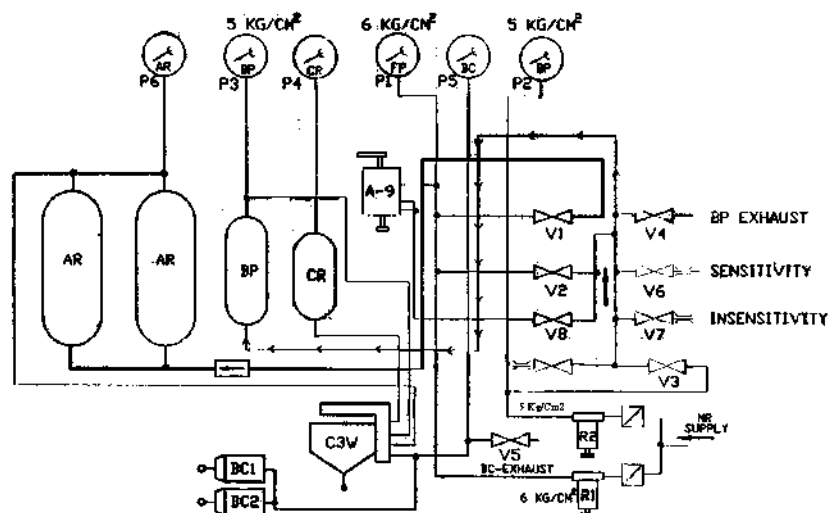
- i) Test bench
- ii) Compressed air supply source for supplying air pressure at 7.5 Kg/cm<sup>2</sup>
- iii) Stopwatch – 2 No
- iv) Soap water solution

**716. TESTING OF C3W DISTRIBUTOR VALVE****A. DESCRIPTION OF THE TEST BENCH**

The schematic diagram of the test bench for C3W valve is shown in the Fig. 7.21.

**TEST RACK FOR C3W DISTRIBUTOR VALVE**

- P1 – Pressure in feed pipe (not applicable in single pipe)
- P2 – Input pr. regulated at 5 Kg/cm<sup>2</sup> in the brake pipeline.
- P3 – Brake pipe reservoir pressure.
- P4 – Pressure in the Control Reservoir (CR)
- P5 – Pressure in the brake cylinder.
- P6 – Pressure in the auxiliary reservoir.



**Fig. 7.22**



***Isolating cocks as given below –***

- V1 – for isolating the supply of air to the auxiliary reservoir at 6 Kg/Cm<sup>2</sup> (i.e. to test the system in single pipe).
- V2 – To connect/isolate BP pressure.
- V3 – for controlling the supply of air to the brake pipe at 5 kg/cm<sup>2</sup>.
- V4 – for exhausting the brake pipe pressure.
- V5 – for exhausting the brake cylinder pressure.
- V6 – It is an isolating cock with a choke for releasing the brake pipe pressure at a desired rate for sensitivity test and for graduated application test.
- V7 – It is a isolating cock with a choke for releasing the brake pipe pressure at a desired rate for insensitivity test
- V8 – For controlling air pressure in the brake pipe with the help of the drivers brake valve.
- V9 – Isolating cock with a choke for increasing the brake pipe pressure in the desired steps for graduated release test and for CR check valve reset test.

***The test bench consists of the following components :***

- (i) Source of compressed air supply at 7.5 kg/cm<sup>2</sup>
- (ii) Pressure regulator R1 - to supply air at 6 kg/cm<sup>2</sup>.
- (iii) Pressure Regulator R2 - to supply air at 5 kg/cm<sup>2</sup>
- (iv) Brake cylinders – 2 No. i.e. BC (1) and BC (2)
- (v) Auxiliary reservoir AR (1) and AR (2) each having a capacity to store 100 litre of air at 6 kg/cm<sup>2</sup>.
- (vi) Brake pipe pressure reservoir having a capacity to store 18 litres of air at 5 kg/cm<sup>2</sup>.
- (vii) Control reservoir cylinder having a capacity to store 6 litres of air at 5 kg/cm<sup>2</sup>.
- (viii) Automatic brake valve (A9), which is used as the drivers brake valve in the locomotive along with the C2 relay valve. This is supplied compressed air at 6 Kg/cm<sup>2</sup>. With the help of the A9 valve, the pressure in the brake pipe can be increased or decreased.
- (ix) Six Pressure Gauges to indicate pressures at different locations.

**B. PREPARATION OF TEST BENCH*****Preparation of the test bench requires the following steps –***

- Setting of the pressure regulators and the brake valve
- Leakage testing of automatic pipe network
- Calibration of chokes

**C. SETTING OF THE REGULATOR AND AUTOMATIC BRAKE VALVE**

- (i) Block C3W distributor connections by putting blanking gasket in between the distributor and its pipe bracket.
- (ii) Close all isolating cocks (i.e. V1 to V9).
- (iii) Supply compressed air at 7.5 kg/cm<sup>2</sup> at the test rack intake.
- (iv) Adjust the regulators R1 and R2 so that the pressure gauges P1 and P2 indicate the pressure as 6 kg/cm<sup>2</sup> and 5 kg/cm<sup>2</sup> respectively
- (v) Open isolating cock V3 and note that both the gauges P3 (i.e. Brake pipe reservoir pressure) and P2 (brake pipe pressure ) show 5 kg/cm<sup>2</sup>
- (vi) Close isolating cock V3 and open cock V4 to vent out BP. reservoir pressure.

Gauge P3 will indicate zero pressure in this condition

- (vii) Adjust drivers brake valve A9 at 5 Kg/cm<sup>2</sup>, check this adjustment by opening isolating cock V8. This will increase BP reservoir pressure to 5 Kg/cm<sup>2</sup> and this can be checked by gauge P3.
- (viii) Close the cock V8

#### **D. LEAKAGE TESTING OF PIPE NETWORK**

- Open isolating cock V1 to charge the auxiliary reservoir to 6 kg/cm<sup>2</sup>
- Check this pressure from the pressure gauge P6
- Open isolating cock V2 to overcharge the brake pipe pressure to 6 kg/cm<sup>2</sup>. Check this pressure from the pressure gauge P3
- When pressure in the pressure gauges P6 and P3 are stabilised at 6 kg/cm<sup>2</sup> then close isolating cocks V1 and V2. Wait for one minute for stabilising of pressure in gauges P3 and P6.
- Leakage must not exceed 0.1 kg/cm<sup>2</sup> in one minute as shown by these gauges
- If there is any leakage. Identify its location with the help of soap solution and arrest the leakage before proceeding further.

#### **E. TEST PROCEDURE**

Tests are conducted in a particular sequence for reducing the time required in opening and closing of various valves. In the test bench described above, following test sequence is optimum as far as the time required in testing distributor valves are concerned. In any other type of test bench arrangement, some other test sequence may be optimum. The valve V1 is kept closed during testing.

**Note :** Although pressure tightness test is supposed to be conducted in the beginning for every position of the distributor valve. But in this arrangement of test bench, it is convenient to conduct charging time test before pressure tightness test.

##### **(I). Charging time of auxiliary reservoir and control reservoir.**

- a) Close all the isolating cocks.
- b) Set air pressure regulator R1 and R2 at 6 and 5 Kg/cm<sup>2</sup> respectively.
- c) Check pressure in the pipe by P1 and P2. It should be 6 and 5 Kg/cm<sup>2</sup> respectively. If required, adjust the pressure regulator R1 and R2 to achieve these pressures.
- d) Open isolating cock V3 and with the help of a stopwatch, note time taken by gauge P4 (CR) and P6 (AR) to rise from 0 to 4.8 Kg/cm<sup>2</sup>. Two separate stopwatches will be required. It is better if two persons monitor these pressures separately.
- e) For control reservoir, the charging time should be 260±20 seconds and for auxiliary reservoir it should be 270±30 seconds.

##### **(II). Pressure tightness test**

- a) Apply soap water all over C3W valve. No leakage is permissible.
- b) Close isolating cock V3 after pressure gauges. P3 (Brake pipe), P4 (Control reservoir) and P6 (Auxiliary reservoir) indicates 5 Kg/cm<sup>2</sup>. Wait till reading in gauges settle.
- c) Switch on a stopwatch and monitor pressure in these gauges. There should be no

drop in pressure in one minute duration.

**(III). Full service application and release test.**

- a) Automatic brake valve should be set at 5 Kg/cm<sup>2</sup> (as done during setting of the test bench). Bring handle in release position.
- b) Open isolating cock (V8) and note gauges P4 (CR) and P6 (AR) shows exactly 5Kg/cm<sup>2</sup>.
- c) Move A9 handle to service application position, so that P3 (Brake pipe pressure) falls from 5 to 3.4 Kg/cm<sup>2</sup>.
- d) Switch on the stopwatch as soon as the handle of A9 is moved to service application position in the above step and note the time taken by brake cylinder pressure (P5) to rise from 0 to 3.6 Kg/cm<sup>2</sup>. This time should be 18 to 30 seconds.
- e) Wait for brake cylinder pressure (P5) to settle and note the maximum pressure to which it reaches. The maximum pressure should be  $3.8 \pm 0.1$  Kg/cm<sup>2</sup>.
- f) Move A9 handle to release position and switch on the stopwatch immediately to note the time taken by brake cylinder pressure (P5) to fall from 3.8 to 0.4 Kg/cm<sup>2</sup>. This time should be within 15 to 20 seconds.

**(IV). Overcharge protection test**

- a) When A9 handle is in release position, brake pipe, auxiliary reservoir and control reservoir pressures i.e. pressures in gauges P3, P4 and P6 should be at 5 Kg/cm<sup>2</sup>.
- b) Move A9 handle to emergency position. In this case brake pipe pressure (as per gauge P3) will fall to zero and brake cylinder pressure (as per P5) will reach to its maximum value.
- c) Close isolating cock V8 and move A9 handle to release position. In this position brake pipe pressure (P3) will again rise to 5 Kg/cm<sup>2</sup> and brake cylinder pressure (P5) will fall to zero, while auxiliary reservoir pressure (P6) and control reservoir pressure (P4) will be around 5 Kg/cm<sup>2</sup>.
- d) Open isolating cock V2 and overcharge brake pipe to 6 Kg/cm<sup>2</sup> for 25 seconds (see it in gauge P3) and then immediately close isolating cock V2 and open cock V8. But during this, control reservoir should not be overcharged by 0.1 Kg/cm<sup>2</sup> over regime pressure of 5 Kg/cm<sup>2</sup> (as seen by gauge P4).

**(V). CR over charge reduction test**

- a) Allow over charging of CR and AR at 5.7 Kg/cm<sup>2</sup> and bring back BP pressure to 5 Kg/cm<sup>2</sup> by closing the isolating cock V2 and V1.
- b) Pull the double release lever of DV for 3 seconds and note down the fall in pressure of control reservoir.
- c) The control reservoir pressure should return back to brake pipe pressure i.e. 5 Kg/cm<sup>2</sup> as seen by P3.

**(VI). Emergency application test**

- a) With brake pipe, control reservoir and auxiliary reservoir (i.e. P3, P4 and P6) charged to 5 Kg/cm<sup>2</sup>. Move A9 handle to emergency application position.
- b) As soon as handle is moved to emergency application position, switch on the stopwatch and note down the time taken by the brake cylinder pressure (P5) to rise from 0 to 3.6 Kg/cm<sup>2</sup>. This time should be between 3 to 5 seconds.
- c) Also note the maximum pressure to which brake cylinder is charged. This pressure should be  $3.8 \pm 0.1$  Kg/cm<sup>2</sup>.

**(VII). Sensitivity test**

- a) Move A9 handle to release position to recharge the brake pipe pressure (P3) to 5 Kg/cm<sup>2</sup>.
- b) Close isolating cock V8.
- c) Open isolating cock V6. Switch on the stopwatch as soon as isolating cock V6 is opened and note the time taken by brake pipe pressure to drop by 0.6 Kg/cm<sup>2</sup>. This time should be 6 seconds.
- d) Brake cylinder pressure (P5) should start rising within 1 second and within 6 seconds piston should start moving for application of brakes.

**(VIII). Quick service test**

Close isolating cock V6 and immediately observe the applied brakes, they should remain applied.

**(IX). Insensitivity test**

- a) Open isolating cock V3 to recharge BP, CR and AR to 5 Kg/cm<sup>2</sup> (as seen by P3, P4 and P6).
- b) Close isolating cock V3 and open isolating cock V7.
- c) As soon as isolating cock V7 is opened, start stopwatch and check that BP pressure (P3) drops by 0.3 Kg/cm<sup>2</sup> in 60 seconds.
- d) There should not be any rise in brake cylinder pressure and brake cylinder piston should not start moving i.e. brakes should not apply.

**(X) Re-feeding test**

- a) Close isolating cock V7 and open V3 to recharge brake pipe, control reservoir and auxiliary reservoir to 5 Kg/cm<sup>2</sup> (As seen by P3, P4 and P6 respectively).
- b) Bring A-9 valve handle to full service application position. BC pressure will become  $3.8 \pm 0.1$  Kg/cm<sup>2</sup> (as seen by P5).
- c) Exhaust the brake cylinder by slightly opening the isolating cock no V5.
- d) Observe brake cylinder pressure in the gauge no. P5. It should not become zero and should stabilize at some particular value (since re-feeding to brake cylinder is available via distributor valve).
- e) Fall in brake cylinder pressure should not be more than 0.15 Kg/cm<sup>2</sup> from  $3.8 \pm 0.1$  Kg/cm<sup>2</sup> (i.e. it should not fall below  $3.65 \pm 0.1$  Kg/cm<sup>2</sup>).
- f) Close exhaust cock no. V5.

**(XI). Graduated application test**

- a) See that brake pipe, control reservoir and auxiliary reservoir are at 5 Kg/cm<sup>2</sup> (as seen by P3, P4 and P6 respectively).
- b) Close isolating cock V3.
- c) Decrease P3 (BP) pressure in steps of 0.2 Kg/cm<sup>2</sup> (min 7 steps) by slowly opening and closing cock V6 i.e. starting from 4.6 Kg/cm<sup>2</sup> and then to 4.4, 4.2, 4.0, 3.8, 3.6 and 3.4 Kg/cm<sup>2</sup>.
- d) Note down the corresponding increase in brake cylinder pressure (P5).
- e) Also note the brake pipe pressure (P3) at maximum brake cylinder pressure (P5). This BP pressure (P3) should be 3.4 to 3.7 Kg/cm<sup>2</sup>.

**(XII). Graduated release test**

- a) Close isolating cock V6.
- b) Increase brake pipe pressure (P3) in steps of 0.2 Kg/cm<sup>2</sup> by opening and closing cock V9. The Brake pipe pressure will rise from 3.6 to 3.8 Kg/cm<sup>2</sup>.
- c) Note corresponding decrease in the brake cylinder pressure (P5).
- d) Also note the maximum pressure of brake pipe (P3) at which brake cylinder pressure (P5) is exhausted completely. This pressure should be 4.85 Kg/cm<sup>2</sup>.

**(XIII). Quick release test**

- a) Close isolating cock V9.
- b) Open isolating cock V3 to charge brake pipe, auxiliary reservoir and control reservoir pressure (P3, P4 and P6) to 5 Kg/cm<sup>2</sup>. Close isolating cock V3 when pressure in P3, P4 and P6 stabilizes.
- c) Open isolating cock V4 for emergency application and see that. Brake cylinder (P5) is charged to 3.8 Kg/cm<sup>2</sup>.
- d) Make a short pull on the release valve handle. As soon as this handle is pulled, control reservoir (P4) and brake cylinder (P5) should be completely vented.
- e) Close cock V4.

**(XIV). CR check valve reset test**

- a) Continue to pull the release valve handle of the distributor valve to completely vent out auxiliary reservoir (P6).
- b) Recharge by opening cock V9.
- c) Control reservoir (gauge P4) should be isolated from the atmosphere when brake pipe (gauge P3) pressure exceeds 0.2 Kg/cm<sup>2</sup>.

**717. KE DISTRIBUTOR VALVE**

These valves are also referred as KEO and KEGiSL in some publications. The KE distributor valve consists of the following main subassemblies:

- |                          |                             |
|--------------------------|-----------------------------|
| (a) Three pressure valve | e) Minimum pressure limiter |
| (b) U controller         | f) Maximum pressure limiter |
| (c) R charger            | g) A controller             |
| (d) Choke cover          | h) Quick release valve      |

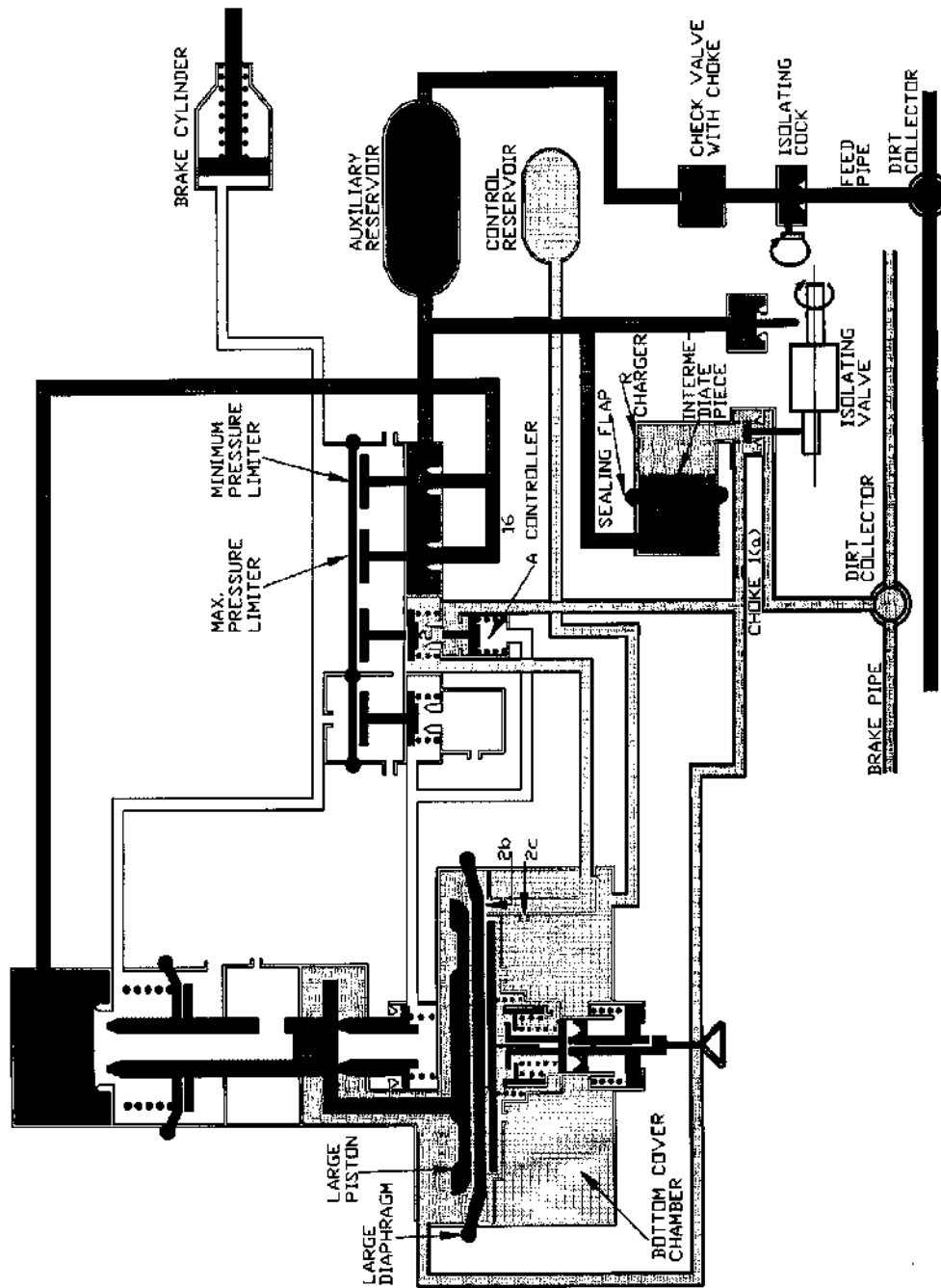


Fig. 7.23 KE DISTRIBUTOR VALVE

## A. DESCRIPTION OF VARIOUS SUB-ASSEMBLIES OF KE GISL DISTRIBUTOR VALVE

### (a) THREE PRESSURE VALVE

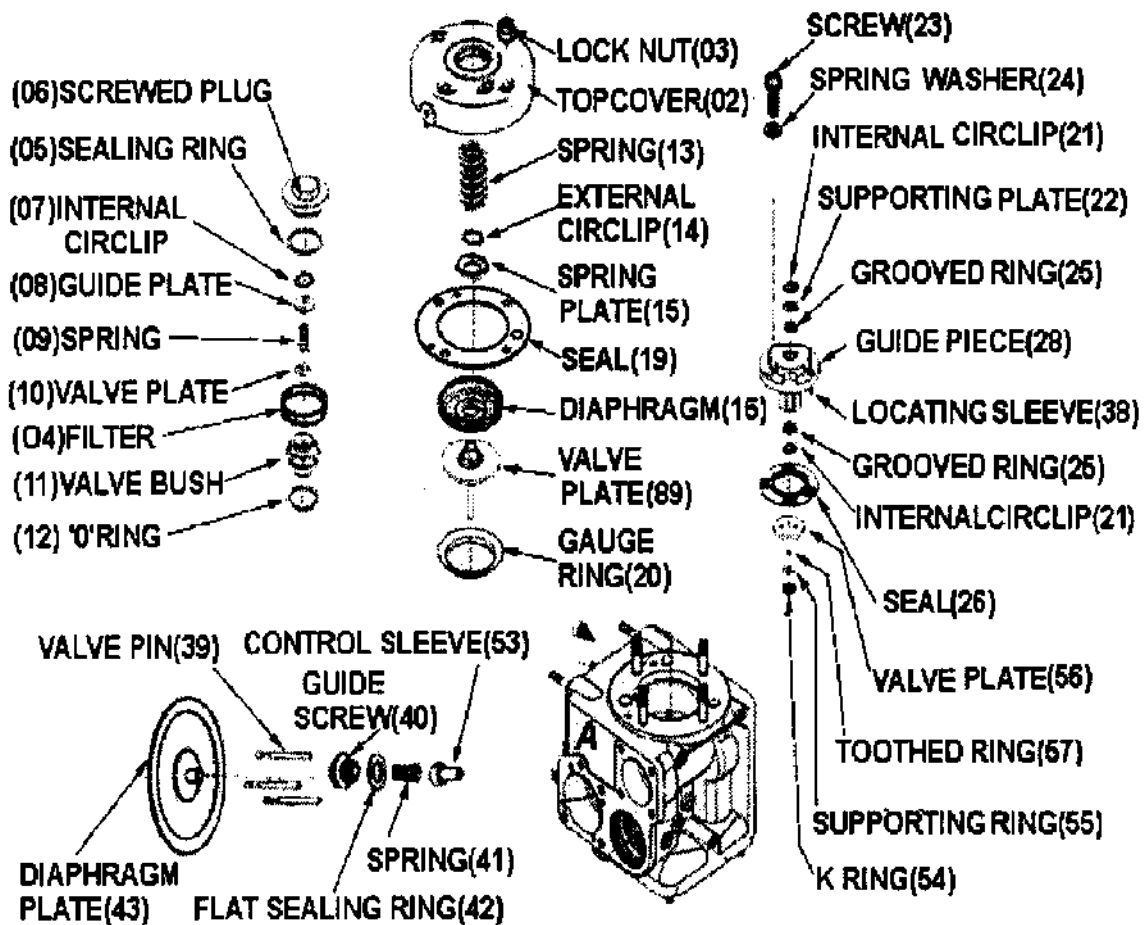


Fig. 7.24 THREE PRESSURE VALVE

The three pressure valve is housed in the vertical central bore between the top and bottom face. The function of the three pressure valve is to control charging and discharging of the brake cylinder in accordance with the change in the brake pipe pressure. The three pressure valve responds to the slightest variation of brake pipe pressure. The U controller, R charger and choke cover are housed on one face of the distributor valve.

(b) U-CONTROLLER

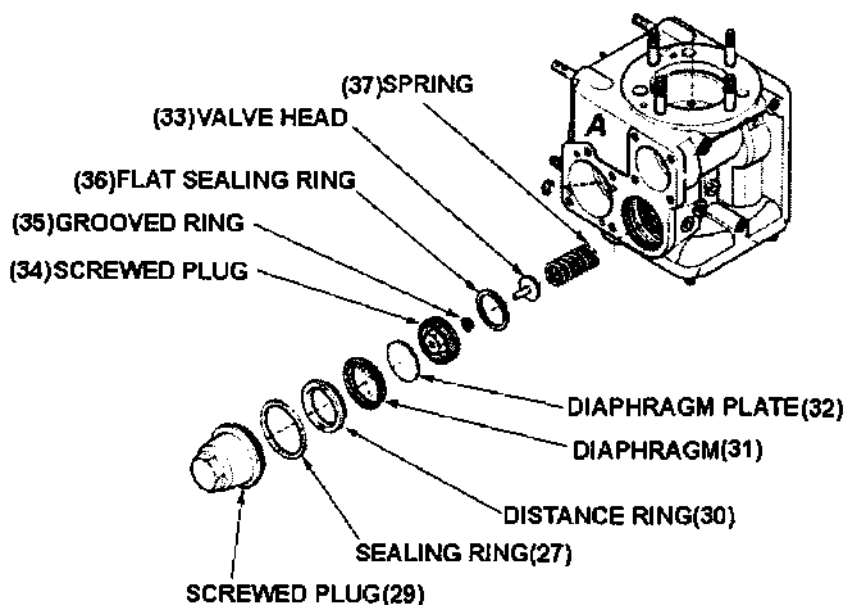


Fig. 7.25 U CONTROLLER

The function of the ‘U’ controller is similar to the function of quick service valve of C3W Distributor Valve. The U-controller gets activated during start of the brake application and taps off a small amount of brake pipe pressure from Distributor Valve during initial brake application. This action increases initial pressure reduction & causes simultaneous rapid propagation of braking impulse throughout the length of the train.

(c) ‘R’ CHARGER

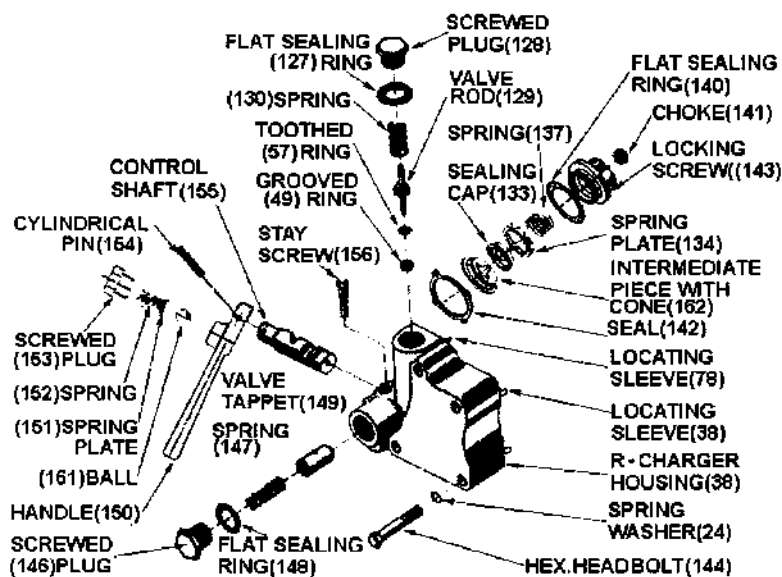


Fig. 7.26 R-CHARGER



The function of the 'R' charger is to supply compressed air from the brake pipe to the auxiliary reservoir 'R' charger also separate the auxiliary reservoir from the brake pipe through check valve (which is located inside 'R' charger) when BP pressure is less than AR pressure.

#### (d) CHOKE COVER

The choke cover has application & release chokes inside it. The application and release chokes help in regulating the application and release times of brake.

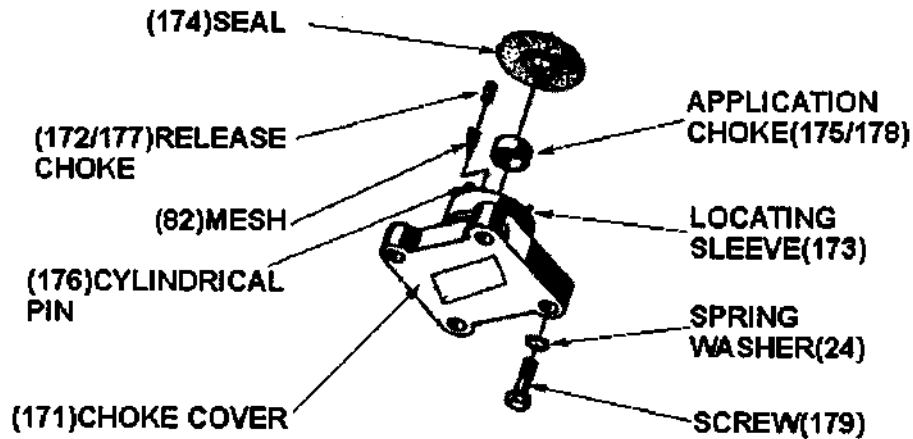


Fig. 7.27 CHOKE COVER

On the face opposite to face 'A' are housed, maximum pressure limiter, minimum pressure limiter and 'A' controller.

#### (e) MINIMUM PRESSURE LIMITER

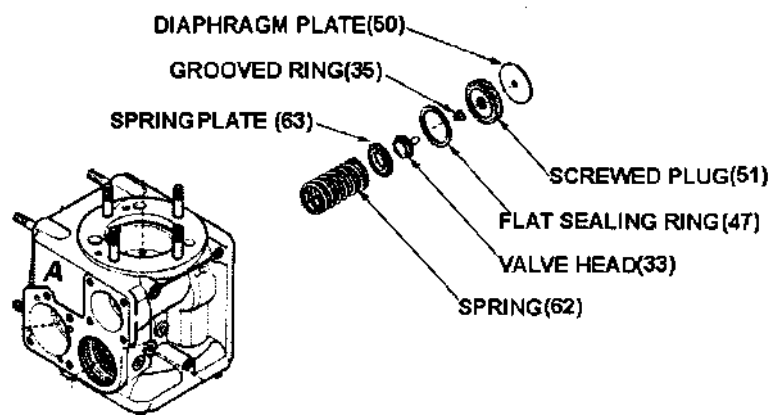
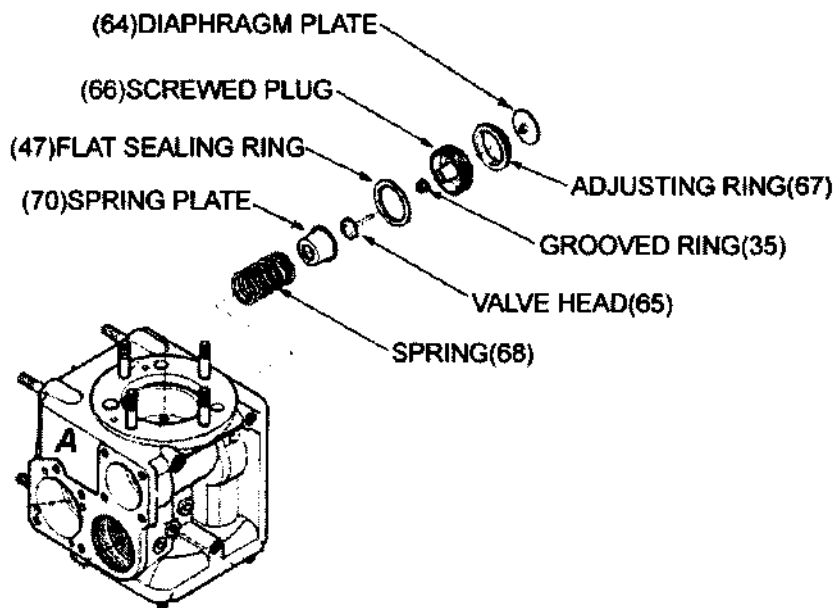


Fig. 7.28 MINIMUM PRESSURE LIMITER

The minimum pressure limiter gets activated during initiation of brake application. The minimum pressure limiter helps in rapid charging of brake cylinder upto a determined pressure to overcome rigging resistance.

**(f) MAXIMUM PRESSURE LIMITER**



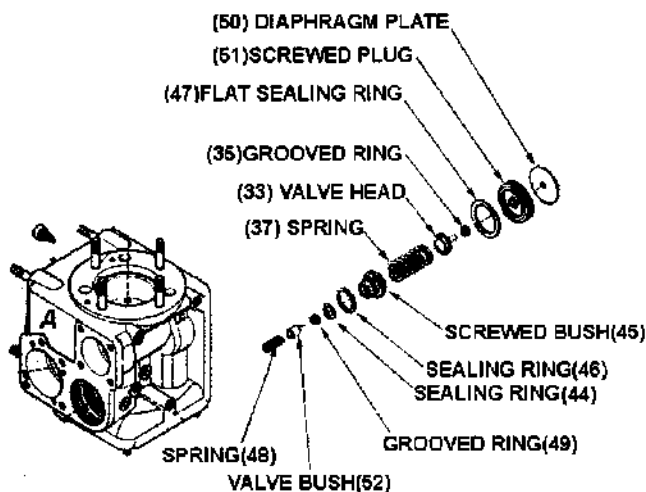
**Fig. 7.29 MAXIMUM PRESSURE LIMITER**

The function of maximum pressure limiter is similar to the limiting device in the C3W Distributor valve. The maximum pressure limiter limits the maximum brake cylinder pressure to  $3.8 \pm 0.1 \text{ kg/cm}^2$  irrespective of the auxiliary reservoir pressure.

**(g) 'A' CONTROLLER**

The function of 'A' controller is similar to that of cut off valve of the C3W Distributor Valve.

Besides charging control reservoir during charging operation 'A' controller isolates control reservoir pressure when brakes are applied. 'A' controller also protects control reservoir from overcharging.



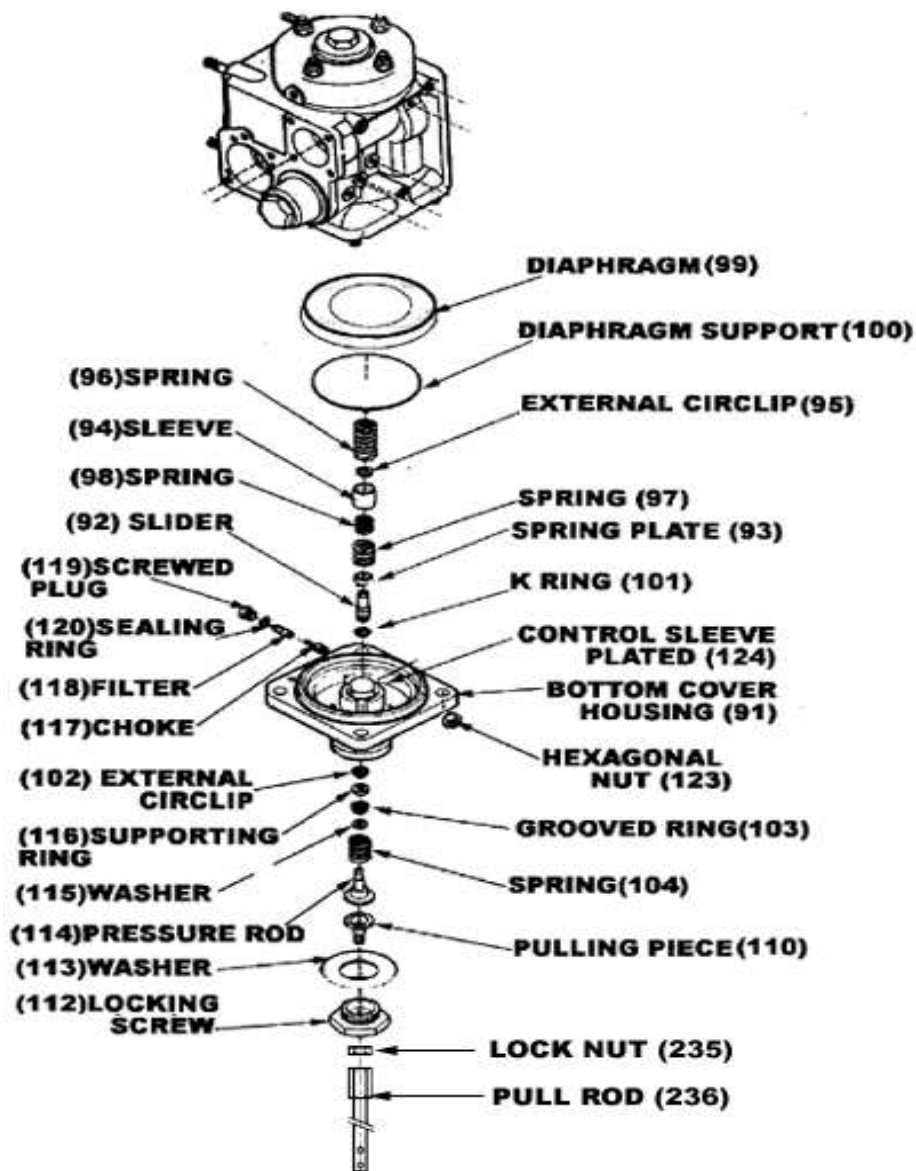
**Fig. 7.30 A-CONTROLLER**

**(h) QUICK RELEASE VALVE**

The quick release valve allows the brakes of the wagons to be fully released by means of manually pulling of handle.

For effective functioning of the air brake system, the KE Gisl distributor valve has to operate effectively during :

- Charging stage
- Application stage and
- Release stage



**Fig. 7.31 QUICK RELEASE VALVE**

**717 A. FUNCTIONING OF KE DISTRIBUTOR VALVE****(a) CHARGING STAGE**

During this stage, the compressed air flows from the driver's brake valve into the brake pipe which charges the control reservoir, bottom cover chamber and auxiliary reservoir. During charging stage, the path followed by compressed air is as follows.

**(i) Charging of control reservoir**

During charging, the compressed air flows from brake pipe, dirt collector, isolating valve and through choke to brake pipe chamber above the large piston and to the 'A' controller. Due to brake pipe pressure acting on top of the large piston, the three pressure valve is pushed down and the port gets closed by the large diaphragm.

Air also flows to the 'A' controller through choke. It passes through sensitivity port, and from there to the bottom cover chamber through port. From the bottom cover chamber, the air enters the control reservoir. When the BP pressure above the large diaphragm gets equal to control reservoir pressure (at bottom cover chamber), the large piston diaphragm gets lifted up and opens the port.

**(ii) Charging of Auxiliary Reservoir**

For charging the auxiliary reservoir, air from BP passes from dirt collector to the 'R' charger via the isolating valve. Air entering the 'R' charger passes through the intermediate piece and opens the sealing flap. There from, air enters the auxiliary reservoir and charges it to 5kg/cm<sup>2</sup>.

**(b) APPLICATION STAGE**

The application of brakes can either be emergency, full service or graduated.

**(i) Emergency application:**

When the brake pipe pressure is reduced from 5kg/cm<sup>2</sup> to zero the passage from auxiliary reservoir to the brake pipe is closed by the sealing flap in the 'R' charger, because of differential pressure acting on either side of the sealing flap. At the same time pressure differential acts across the large diaphragm of the three pressure valves which pushes the piston unit (large & small) upwards. The upward movement of the piston unit closes the outlet port by uplifting of the control sleeve.

In addition to this, the outlet port at the top of the three pressure valve closes and the inlet port opens. The air from auxiliary reservoir through the minimum pressure limiter, the maximum pressure limiter and the choke, enters the top of the three pressure valve and through the open inlet port, the air enters into the brake cylinder.

When the pressure in the brake cylinder reaches 0.8 kg/cm<sup>2</sup>, first minimum pressure limiter gets closed and there after maximum pressure limiter gets closed when the pressure in the brake cylinder reaches 3.8 kg/cm<sup>2</sup>. With the rise in BC pressure the 'A' controller gets closed, maintaining the pressure in the control reservoir.

During full brake application, the brakes are applied at slower rate than in emergency application. BP pressure to be reduced by 1.5 kg/cm<sup>2</sup> instead of 5 kg/cm<sup>2</sup>.

**Note:** At the beginning i.e. when BP pressure is reduced and control sleeve lifts outlet port of BP, air from top of the control sleeve reaches U-chamber that is already open to atmosphere and some BP air thus vents off. This causes a sudden extra drop in the remaining BP pressure inside the DV and accelerates the effect of brake application, propagating this action throughout the length of the train.

By this action brake cylinder pressure starts rising. The brake cylinder pressure also acts on diaphragm at U-controller, A controller, Minimum Pressure limiter and maximum pressure limiter. As BC start to rise the A controller valve is closed isolating BP and CR. Also the U controller is closed and local reduction of BP is stopped. As BC reaches 0.8 kg, it closes the minimum pressure limiter and now the rising BC pressure can pass through maximum limiter through choke which regulates the rate of BC rising. As BC reaches  $3.8 \pm 0.1$  kg per sq. cm., maximum pressure limiter also closes and no further rise of BC is possible. This rise of BC to  $3.8 \pm .1$  kg per sq. cm. comes to effect at BP pressure dropping to 1.5 kg/sq. cm.

**(ii) Graduated application**

When the brake pipe pressure is reduced in steps for graduated application of brakes, the increase in brake cylinder pressure is at a controlled rate and in proportion to brake pipe pressure reduction.

As soon as the brake cylinder pressure rises in proportion to brake pipe pressure reduction, it causes the piston unit (large & small) to move down into lap position thereby closing the top inlet port without opening the top outlet port. Thus feeding of air from the auxiliary reservoir to the brake cylinder is cut off. This cycle is repeated every time BP is reduced in steps effecting graduated application of brakes.

**(c) RELEASE STAGE**

For releasing the brakes, the pressure in the brake pipe is increased and the pressure above the large piston increases. Thus the differential pressure across the large piston reduces. As a result, the piston unit (large & small) moves down thereby opening the top outlet port and closing the top inlet port. The brake cylinder pressure thus passes through the outlet port and gets exhausted to atmosphere through the release choke. As the BP pressure reaches 4.85 kg/cm<sup>2</sup>, the brake cylinder is almost completely drained and the three pressure assembly attains its charging/running position again.

**(i) Graduated release**

If the pressure in the brake pipe is increased in steps, the releasing procedure starts as before. However the top outlet port get closed and come to lap position as soon as piston unit (large & small) moves up due to fall of brake cylinder pressure.

**ii) Manual Release**

Sometimes manual release of brakes is very helpful and thus provision is made in the distributor valve for manually releasing the brakes. When a short pull is given to pulling lever, it tilts the pressure piece. As a result, the pressure rod and pin are pushed upwards against force of spring. The air thus flows from control reservoir and passes through port and then from narrow passage to atmosphere. This will continue until the brake pipe pressure acting on large piston moves the supporting plate down. This results in downward movement of the pin thereby closing the passage of air to exhaust.

If however, there is no more pressure in brake pipe (i.e. after emergency application), when short pull is given to release handle then pressure piece is tilted & pin remains in top position. As a result control reservoir pressure is completely exhausted. The tilted pressure piece is then immediately restored to its initial position by spring. The brake cylinder pressure starts exhausting after control reservoir is exhausted upto 1.2 kg/cm<sup>2</sup>. and then simultaneously both get exhausted completely.

During refilling, the pressure in brake pipe rises more rapidly via choke and port so that the large piston immediately moves down causing the pin to move to lap position.

### 717 C. SPECIFICATION OF KE DISTRIBUTOR VALVE

KE distributor valve is a graduated release type of valve and has been approved by UIC to comply with requirement of its specification no. 540 and 547.

### 718. TESTING OF KE TYPE DISTRIBUTOR VALVE

Schematic diagram of the test bench for KE valve is shown in Fig. 7.32. Test bench consists of the following components:-

- (i). Source of compressed air supply at 7.5 Kg/cm<sup>2</sup>.
- (ii). Pressure regulator (Item no. 4) : to supply air at 6.5 Kg/cm<sup>2</sup>.
- (iii). Pressure regulator (Item no. 24): to supply air at 6 Kg/cm<sup>2</sup>.
- (iv). Brake cylinders (Item no. 17) : two numbers
- (v). Auxiliary reservoir [Item no 21(A) and 21(B)] each having capacity to store 100 liters of air at 6 Kg/cm<sup>2</sup>.
- (vi). Brake pipe reservoir (item no. 9) having capacity to store 60 liters of air at 6 Kg/cm<sup>2</sup>.
- (vii). Equalizer reservoir (Item no. 7) to store air at 6 Kg/cm<sup>2</sup> pressure. This reservoir supplies air to drivers brake valve whenever it is needed by DBV due to loss of air.
- (viii). Drivers brake valve (item no. 6). It is same as provided in the locomotive. Its purpose is to control the brake pipe pressure.
- (ix). Item no. 2 : Filter in supply to filter out any oil, grease etc.
- (x). Item no. 22 : Auxiliary reservoir check valve. This prevents back flow of air i.e. flow of air from auxiliary reservoir to supply.
- (xi). Item no. 5 : Main reservoir to store 60, liters of air at 6.5 Kg/cm<sup>2</sup>.
- (xii). Item no. 14 : Common pipe bracket, KE type distributor valve which is under test is to be mounted on this.
- (xiii). Five pressure gauges to indicate the pressure in different locations as given below –
  - Item no. 25 : Main reservoir pressure.
  - Item no. 26 : Brake pipe pressure
  - Item no. 27 : Control reservoir pressure
  - Item no. 28 : Auxiliary reservoir pressure
  - Item no. 29 : Brake cylinder pressure.
- (xiv). Isolating cocks as given below-
  - Item no. 1: Supply of compressed air to main reservoir.
  - Item no. 3 : For exhausting main reservoir pressure.
  - Item no. 8 : For controlling air pressure in brake pipe with the help of drivers brake valve.

- Item no. 10 : For isolating common pipe bracket from the brake pipe reservoir.
- Item no. 11 : For exhausting brake pipe pressure.
- Item no. 12 : It is with a choke for releasing brake pipe pressure at a desired rate for insensitivity test.
- Item no. 13 : It is with a choke for releasing brake pipe pressure for sensitivity test.
- Item no. 15 : Provided between brake pipe line and control reservoir. Normally it is kept closed and is used only for quick charging (or direct charging) of the control reservoir.
- Item no. 16 : Isolating cock with a choke for exhausting brake cylinder pressure at a desired rate.
- Item no. 19 : For isolating auxiliary reservoir from common pipe bracket.
- Item no. 20 : Provided between brake pipe and auxiliary reservoir for direct charging of brake pipe (I.e. by bypassing the driver's brake valve).
- Item no. 23 : It is the cock which connects the auxiliary reservoir with feed pipe in twin pipe system. This valve is kept closed in single pipe operation.
- Item no. 30 : For exhausting auxiliary reservoir.

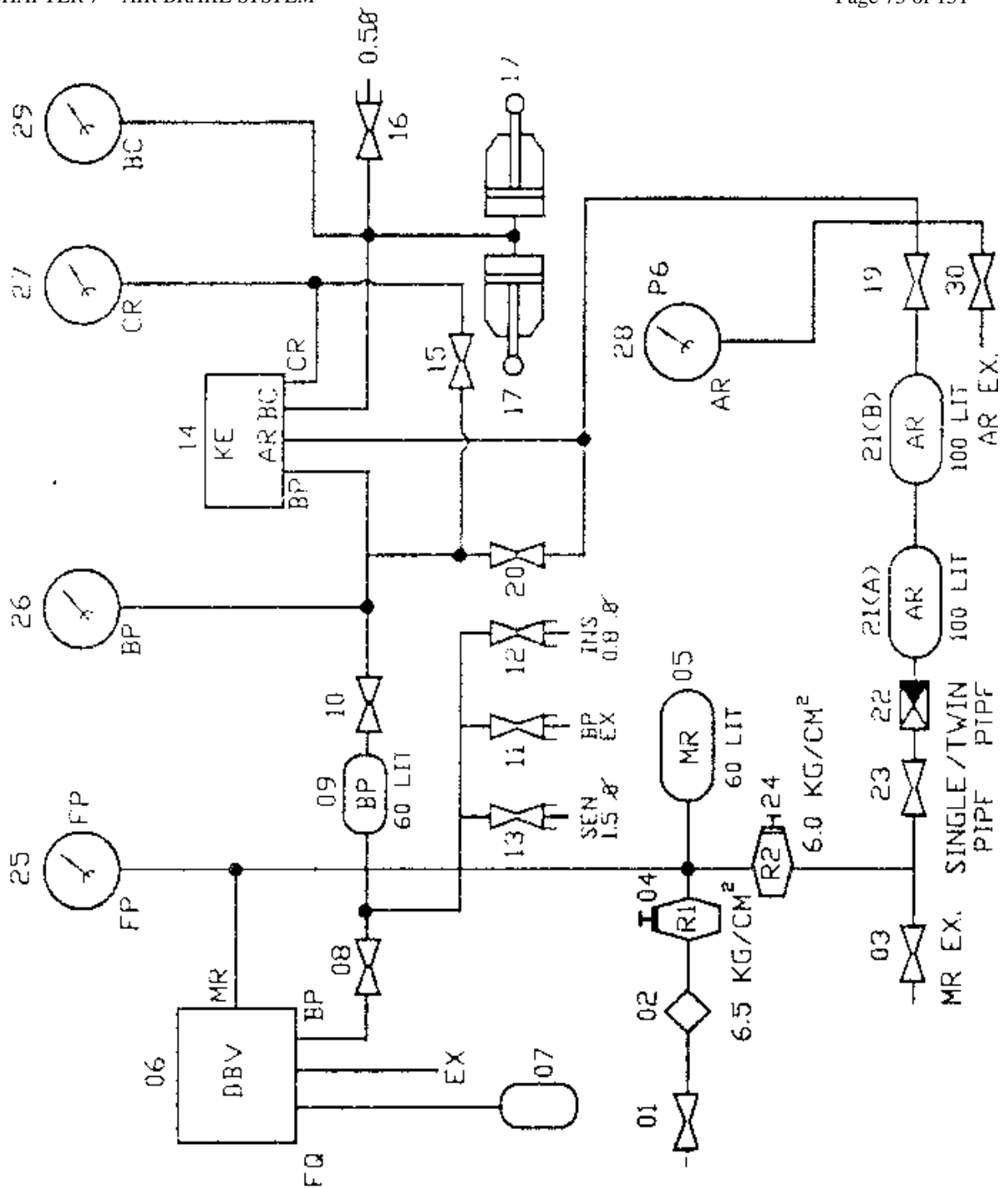


Fig. 7.32 TEST BENCH FOR KE DISTRIBUTOR VALVE



**719. TEST REPORT PROFORMA FOR C3W/KE  
DISTRIBUTOR VALVE**

Type of Valve .....

Sr. No. ....

Sr. No.	Description of Test		Observation
1.	AR Charging Time from 0 to 4.8 Kg/cm <sup>2</sup> (Main Reservoir pressure > 7.5 Kg/cm <sup>2</sup> )		
2.	CR Charging Time from 0 to 4.8 Kg/cm <sup>2</sup> (Main Reservoir pressure >7.5 Kg/cm <sup>2</sup> )		
3.	Leakage Test (Brake Release) Check DV Leakage by Soap water only at joints.		
	<b>FULL SERVICE APPLICATION &amp; RELEASE</b>		
3.1	Brake Cylinder filling time from 0 to 3.6 Kg/cm <sup>2</sup>	18 to 30 seconds ±0.1	
3.2	Maximum Brake Cylinder Pressure	3.8 Kg/cm <sup>2</sup>	
3.3	Leakage Test (Application) Check Leakage in DV by Soap water only at joints		
3.4	Brake Cylinder Release Time from Max.B.C. Pressure i.e. from 3.8 +/-0.1 Kg/cm <sup>2</sup> to 0.4 Kg/cm <sup>2</sup>	45 to 60 Seconds	
4.1	<b>OVERCHARGE PROTECTION</b> (BP pressure 6 Kg/cm <sup>2</sup> )	CR pressure should not increase by more than 0.1 Kg/cm <sup>2</sup> in 25 sec.	
5.1	CR overcharge reduction test Overcharge CR to 5.7 Kg/cm <sup>2</sup> and pull double release lever for 3 seconds.	Overcharged CR should come to regime pressure of 5 Kg/cm <sup>2</sup> .	
	<b>EMERGENCY APPLICATION</b>		Single pipe
6.1	Brake Cylinder filling Time from 0 to 3.6 Kg/cm <sup>2</sup>	18 to 30 Seconds	
6.2	Maximum Brake Cylinder Pressure	3.8 ± 0.1 Kg/cm <sup>2</sup>	
6.3	Leakage Test (Emergency) Check Leakage in DV by Soap water only at joints	No Leakage	
6.4	Brake Cylinder Release Time from Max. B. C. Pressure i.e. from 3.8 ± 0.1 Kg/cm <sup>2</sup> to 0.4 Kg/cm <sup>2</sup>	45 to 60 Seconds	
	<b>SENSITIVITY &amp; INSENSITIVITY</b>		
7.1	BP pressure drop at the rate of 0.6 Kg/cm <sup>2</sup> in 6 Seconds	Brake should start applying within 1 Sec.	
8.1	With a pressure drop stopped immediately after the operation of Quick Service Valve	Brakes must remain applied.	
9.1	BP pressures drop of 0.3 Kg/cm <sup>2</sup> maximum in 60 seconds.	Brakes must not apply.	

Sr. No.	Description of Test		Observation
	<b>REFEEDING</b>		
10.1	Create leak in BC through a 2 mm choke	BC pressure should decrease initially but re-feeding should be available and BC pressure should get stabilized at some pressure.	
11.1	<b>GRADUATED APPLICATION</b> Decrease BP pressure in steps as below - BP Pressure (Kg/cm <sup>2</sup> ) 4.8 4.6 4.4 4.2 4.0 3.8 3.6		
11.2	Continue Graduated Application until max. BC Pressure is obtained	BP pressure drop must be between 1.4 and 1.6 Kg/cm <sup>2</sup>	
11.3	BP Pressure at maximum brake application	BP pressure drop must be between 3.4 & 3.7 Kg/cm <sup>2</sup>	
12.1	<b>GRADUATED RELEASE</b> Increase BP pressure in steps as below – BP Pressure (Kg/cm <sup>2</sup> ) 3.6 3.8 4.0 4.2 4.4 4.6 4.8		BC Pressure
12.2	Check BP Pressure when BC pressure is 0.4 Kg/cm <sup>2</sup> (Recharging pressure to release BC Fully)	4.85 Kg/cm <sup>2</sup> approx.	
13.1	<b>QUICK RELEASE TEST</b> Apply emergency brake & pull briefly the double release valve lever	Brake cylinder & CR are automatically exhausted to zero	
14.1	CR check valve reset test. Start recharging of the system	Control reservoir should be isolated from atmosphere when brake pipe pressure exceeds 0.2 Kg/cm <sup>2</sup> .	

## 720. SINGLE WAGON TEST

‘Single wagon Test’ is performed on a wagon to ensure proper functioning of the air brake system. It is generally performed on the sick wagon attended in the sick line or whenever a subassembly of the air brake system is replaced either in depot or workshop. Single wagon test is also carried out after POH and after every change of distributor valve in the workshop.

The different tests to be performed on the subassemblies of a wagon are as follows:

**Test1: Leakage Test.**

**Test2: Sensitivity and Insensitivity Test.**

**Test3: Brake Application and Release Test.**

**Test4: Graduated Application and Release Test.**

**Test5: Check and adjust Slack Adjuster.**

### A. TOOLS AND EQUIPMENT

1. Test Rig
2. Spanners 10mm, 12mm

### B. CONCEPT

Single Wagon Test is performed, by using a portable device called ‘Test Rig’. This test rig provides all facilities similar to a driver’s brake valve. The source of compressed air for conducting the test is through a compressor installed in depots and workshops for conducting various tests without the need of a locomotive. The part description and specification are given in table below.

### C. PROCEDURE FOR SINGLE WAGON TESTING (Single Pipe)

A systematic lay-out of Single Wagon Test Rig (SWTR) is shown in fig. 7.33. This SWTR is utilised for testing the air brake system fitted on single wagon. The wagon should not be connected with the locomotive at the time of testing. The following procedure shall be followed for testing.

- i. The wagon under testing is to be coupled at one end with the SWTR coupling head BP and the other end should be closed with dummy coupling head. Pressure gauge should be fitted on brake cylinder.
- ii. Couple the SWTR to the main line of compressor.
- iii. Place the isolating cock of distributor valve on the wagon in open position i.e. the handle should be vertically down wards.
- iv. Set the pressure reducing valve (1) to  $5 \pm 0.1$  Kg/cm<sup>2</sup> Open the cocks (2) and (8) and so the angle cocks on the both ends of the wagons. Move the driver’s brake valve (3) in the charging and release position.
- v. Wait for about 5 minutes to charge the complete system.
- vi. Check the pressure in BP pressure gauge (7). Pressure should be  $5 + 0.1$  Kg./cm<sup>2</sup> in BP. If there is pressure drop in the gauge (7) detect the source of leakage and eliminate it.
- vii. Close cocks (2) & (8). Check the leakage on BP for one minute.
- viii. Open cock (2). Bring Driver’s brake valve in full service application position.
- ix. Record the brake cylinder filling time from 0 to 3.6 Kg./cm<sup>2</sup> in brake cylinder pressure gauge.
- x. Record maximum pressure in brake cylinder.
- xi. Record the pressure drop in BP from pressure gauge (4).
- xii. Record the piston stroke of brake cylinder.
- xiii. Bring Driver’s brake valve in the charging and release position.

- xiv. Record the brake cylinder draining time from  $3.8 \pm 0.1$  to  $0.4 \text{ Kg./cm}^2$  in brake cylinder pressure gauge & check complete release of brakes i.e. piston should reach its initial position.
- xv. Open cock (8) for charging the reservoirs to  $5 \text{ Kg./cm}^2$  and close cock (2).
- xvi. Open cock (6) for checking sensitivity of brakes. Record time within which brakes get applied.
- xvii. Close cock (6) and open cock (2). Wait till brakes are released.
- xviii. Close cock (2) and open cock (7) for checking the insensitivity of brakes. The brakes should not apply.
- xix. Close cock (7) and (8) and open cock(2), BP pressure should rise to  $5 \text{ Kg./cm}^2$
- xx. Close cock (2) and open cock (5) for emergency application.
- xxi. Record the brake cylinder charging time from 0 to  $3.6 \text{ Kg./cm}^2$  in BC pressure gauge.
- xxii. Record maximum BC pressure.
- xxiii. Check the leakage in BC for 5 minutes.
- xxiv. Pull the manual release lever of distributor valve for about 10 sec. Brake cylinder pressure should become zero automatically.
- xxv. The above tests should be done in both empty and loaded condition.
- xxvi. The results of test shall be recorded in the test proforma attached herewith.

#### **720-A PROCEDURE FOR SINGLE WAGON TESTING (Twin Pipe)**

A Schematic lay-out of Single Wagon Test Rig (SWTR) is shown in the attached **Figure 7.33A**. This SWTR is utilized for testing the air brake system fitted on single wagon. The wagon should not be connected with the locomotive at the time of testing. The following procedure shall be followed for testing.

- 1 The wagon under testing is to be coupled at one end with the SWTR coupling head BP & FP respectively and the other end should be closed with dummy coupling heads. Pressure gauge should be fitted on brake cylinder.
- 2 Couple the SWTR to the main line of compressor. .
- 3 Check the following on the wagon.
  - 1) Isolating cock of distributor valve should be in open position i.e. the handle should be vertically down wards.
  - 2) Isolating cock in FP line should be in open position i.e, handle should be vertically down wards.
- 4 Set the pressure regulator (1) to  $6 + 0.1 \text{ kg/cm}^2$  open the cocks (2), (5) and (11) and also the angle cocks of both FP and BP on both the ends of the wagons. Move the driver's brake valve (6) in charging and release position.
- 5 Wait for about 5 minutes to charge the complete system.
- 6 Check the pressures in FP pressure gauge (3) and BP pressure gauge (7). Pressure should be  $6 + 0.1 \text{ kg/cm}^2$  in FP and  $5 + 0.1 \text{ kg/cm}^2$  in BP. If there is pressure drop in any of the gauges detect the source of leakage and eliminate it.

- 7 Close cock (2) and check the leakage in FP for one minute.
- 8 Close cocks (5) and (11) and check the leakage on BP for one minute.
- 9 Open cock (2) and (5), bring Driver's brake valve in full service application position.
- 10 Record the brake cylinder filling time from 0 to 3.6 kg/cm<sup>2</sup> in brake cylinder pressure gauge.
- 11 Record maximum pressure in brake cylinder.
- 12 Record the pressure drop in BP from pressure gauge (7).
- 13 Record the piston stroke of brake cylinder.
- 14 Bring Driver's brake valve in charging and release position.
- 15 Record the brake cylinder draining time from 3.8 to 0.4 kg/cm<sup>2</sup> in brake cylinder pressure gauge & check complete release of brakes i.e. piston should reach its initial position.
- 16 Close cock (5) and open cock (11) for charging the reservoir to 5 kg/cm<sup>2</sup>
- 17 Open cock (9) for checking sensitivity of brakes. Record the time within which brakes applied.
- 18 close cock (9) and open cock (5). Wait till brakes are released.
- 19 Close cock (5) and open cock (10) for checking the insensitivity of brakes.
- 20 Close cock (10) and (11) and open cock (5). BP pressure should rise to 5 Kg/cm<sup>2</sup>.
- 21 Close cock (5) and open cock (8) for emergency application.
- 22 Record the brake cylinder charging time from 0 to 3.6 kg/cm<sup>2</sup> in BC pressure gauge.
- 23 Record maximum BC pressure.
- 24 Check the leakage in BC for 5 minutes.
- 25 The above tests should be done in both empty and loaded condition.
- 26 The results of test shall be recorded in the test proforma as given below..

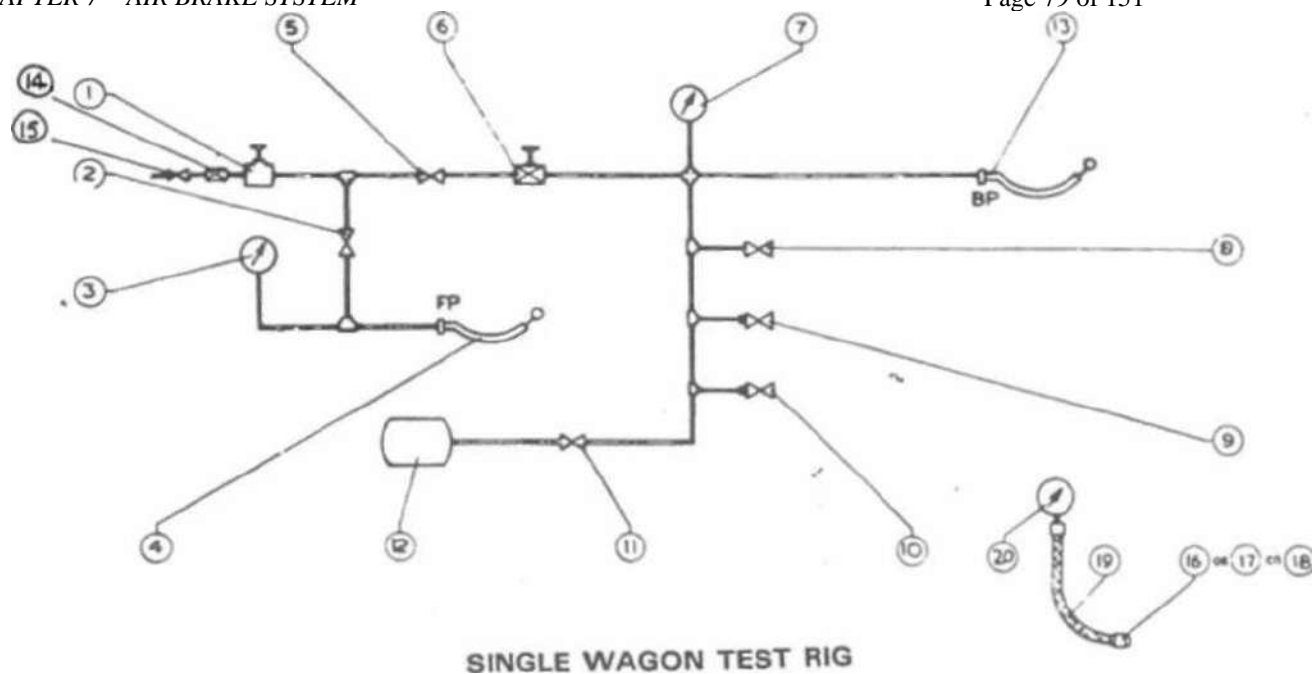


FIG. 7.33A SWTR-Twin pipe

Fig. Ref. No.	Description	Qty.
1.	Pressure reducing valve	1
2.	Isolating cock 15 mm	1
3.	Pressure gauge for FP	1
4.	Flexible hose FP 2.5 M long	1
5.	Isolating Cock 15 mm	1
6.	Drivers brake valve	1
7.	Pressure Gauge for BP	1
8.	Isolating Cock 15 mm	1
9.	Isolating Cock 15 mm with choke	1
10.	Isolating cock 15 mm with choke	1
11.	Isolating Cock 15 mm	1
12.	Air Reservoir 40 L	1
13.	Flexible hose BP 2.5 M long	1
14.	Check valve 15 mm	1
15.	Isolating cock 15mm	1
16.	Adapter for AR	1
17.	Adapter for CR	1
18.	Adapter for BC	1
19.	Flexible Hose 15mmx2 m long	3
20.	Pressure gauge for BC,CR and AR	3
21.	Trolley (Not Shown)	1

**D. PROFORMA FOR SINGLE WAGON TEST FOR WAGONS OTHER THAN BOBR & BOBRN (Single pipe/ Twin pipe)**

<b>S.No.</b>	<b>Check</b>	<b>Specified</b>
1.	Pressure in BP	$5 \pm 0.1$ Kg./cm <sup>2</sup>
1a	Pressure in F.P (In case of Twin pipe)	$6 \pm 0.1$ Kg./cm <sup>2</sup>
2.	Pressure in AR ( in case of single pipe)	$5 \pm 0.1$ Kg./cm <sup>2</sup>
2a	Pressure in AR (In case of Twin pipe)	$6 \pm 0.1$ Kg./cm <sup>2</sup>
3.	Leakage from the system after charging	0.1 kg/cm <sup>2</sup> in one minute
4.	Full service application	
4.1	Brake cylinder filling time (Pressure rise from 0 to 3.6 kg/cm <sup>2</sup> )	
	a) Empty	18 to 30 sec.
	b) Loaded	18 to 30 sec.
4.2	Maximum brake cylinder pressure	
	a) Empty	$3.8 \pm 0.1$ kg/cm <sup>2</sup>
	b) Loaded	$3.8 \pm 0.1$ kg/cm <sup>2</sup>
4.3	Reduction in BP pressure required for full service application	1.3 to 1.6 kg/cm <sup>2</sup>
5.	Release after full service application	
5.1	Draining time (Brake cylinder pressure to fall from $3.8 + 0.1$ kg/cm <sup>2</sup> to 0.4 kg/cm <sup>2</sup> )	45 to 60 sec.
6.	Sensitivity of brakes Isolate brake pipe from mainline. Check the response of brakes when the brake pipe pressure is reduced at the most equal to 0.6 kg/cm <sup>2</sup> in 6 sec.	Brake should apply within 6 sec.
7.	Insensitivity of brake. Isolate brake pipe from mainline. Check the response of brakes when brake pipe pressure is reduced at least equal to 0.3 kg./cm <sup>2</sup> in 60 seconds.	Brake should not apply.
8.	Emergency application	
8.1	Brake Cylinder filling time (Pressure to rise from 0 to 3.6 kg/cm <sup>2</sup> )	
	a) Empty	18 to 30 sec.
	b) Loaded	18 to 30 sec.
8.2	Maximum brake cylinder pressure	
	a) Empty	$3.8 \pm 0.1$ kg/cm <sup>2</sup>
	b) Loaded	$3.8 \pm 0.1$ kg/cm <sup>2</sup>
9.	Piston stroke	
	a) Empty	See note below
	b) Loaded	
10.	Leakage from brake cylinder after emergency application	0.1 kg/cm <sup>2</sup> within 5 minutes
11.	Automatic exhausting of brake cylinder and control Chamber.	

12. Apply emergency brakes (i.e. BP= 0 kg/cm<sup>2</sup>). Check the brake cylinder pressure after giving a brief pull to release hook. Brake cylinder and control reservoirs should exhaust automatically.

Date:

-----  
Signature & Name of testing  
Authority.

**E PROFORMA FOR SINGLE WAGON TEST FOR WAGONS BOBRN TYPES  
(Single pipe/ Twin pipe)**

S.No.	Check	Specified
1.	Pressure in BP	$5 \pm 0.1$ Kg./cm <sup>2</sup>
1a	Pressure in F.P (In case of Twin pipe)	$6 \pm 0.1$ Kg./cm <sup>2</sup>
2.	Pressure in AR ( In case of single pipe)	$5 \pm 0.1$ Kg./cm <sup>2</sup>
2a	Pressure in AR (In case of Twin pipe)	$6 \pm 0.1$ Kg./cm <sup>2</sup>
3.	Leakage from the system after charging	0.1 kg/cm <sup>2</sup> in one minute
4.	Full service application	
4.1	Brake cylinder filling time In Empty (Pressure rise from 0 to 2.1 kg/cm <sup>2</sup> )	18 to 30 sec.
	Brake cylinder filling time In Loaded (Pressure rise from 0 to 3.6 kg/cm <sup>2</sup> )	18 to 30 sec.
4.2	Maximum brake cylinder pressure	
	a) Empty	$2.2 \pm 0.25$ kg/cm <sup>2</sup>
	b) Loaded	$3.8 \pm 0.1$ kg/cm <sup>2</sup>
4.3	Reduction in BP pressure required for full service application	1.3 to 1.6 kg/cm <sup>2</sup>
5.	Release after full service application	
5.1	Draining time (Brake cylinder pressure to fall from $2.2 + 0.25$ kg/cm <sup>2</sup> to 0.4 kg/cm <sup>2</sup> ) In Empty Condition	45 to 60 sec.
	Draining time (Brake cylinder pressure to fall from $3.8 + 0.1$ kg/cm <sup>2</sup> to 0.4 kg/cm <sup>2</sup> ) In Loaded Condition	45 to 60 sec.
6.	Sensitivity of brakes Isolate brake pipe from mainline. Check the response of brakes when the brake pipe pressure is reduced at the most equal to 0.6 kg/cm <sup>2</sup> in 6 sec.	Brake should apply within 6 sec.
7.	Insensitivity of brake. Isolate brake pipe from mainline. Check the response of brakes when brake pipe pressure is reduced at least equal to 0.3 kg./cm <sup>2</sup> in 60 seconds.	Brake should not apply.
8.	Emergency application	



- |     |                                                                                                                                       |                                                                     |
|-----|---------------------------------------------------------------------------------------------------------------------------------------|---------------------------------------------------------------------|
| 8.1 | Brake cylinder filling time In Empty<br>(Pressure rise from 0 to 2.1 kg/cm <sup>2</sup> )                                             | 18 to 30 sec.                                                       |
|     | Brake cylinder filling time In Loaded<br>(Pressure rise from 0 to 3.8 kg/cm <sup>2</sup> )                                            | 18 to 30 sec.                                                       |
| 8.2 | Maximum brake cylinder pressure                                                                                                       |                                                                     |
|     | a) Empty                                                                                                                              | $2.2 \pm 0.25$ kg/cm <sup>2</sup>                                   |
|     | b) Loaded                                                                                                                             | $3.8 \pm 0.1$ kg/cm <sup>2</sup>                                    |
| 9.  | Piston stroke                                                                                                                         |                                                                     |
|     | a) Empty                                                                                                                              | $100 \pm 10$ mm                                                     |
|     | b) Loaded                                                                                                                             | $110 \pm 10$ mm                                                     |
| 10. | Leakage from brake cylinder after emergency application                                                                               | 0.1 kg/cm <sup>2</sup> within 5 minutes                             |
| 11. | Automatic exhausting of brake cylinder and control chamber                                                                            |                                                                     |
| 12. | Apply emergency brakes (i.e. BP= 0 kg/cm <sup>2</sup> ). Check the brake cylinder pressure after giving a brief pull to release hook. | Brake cylinder and control reservoirs should exhaust automatically. |

Date:

-----  
Signature & Name of testing  
Authority.

## F. PROFORMA FOR SINGLE WAGON TEST FOR WAGONS BMBS TYPE (Single pipe/ Twin pipe)

S.No.	Check	Specified
1.	Pressure in BP	$5 \pm 0.1$ Kg./cm <sup>2</sup>
1a	Pressure in F.P (In case of Twin pipe)	$6 \pm 0.1$ Kg./cm <sup>2</sup>
2.	Pressure in AR ( in case of single pipe)	$5 \pm 0.1$ Kg./cm <sup>2</sup>
2a	Pressure in AR (In case of Twin pipe)	$6 \pm 0.1$ Kg./cm <sup>2</sup>
3.	Leakage from the system after charging	0.1 kg/cm <sup>2</sup> in one minute
4.	Full service application	
4.1	Brake cylinder filling time In Empty (Pressure rise from 0 to 2.1 kg/cm <sup>2</sup> )	18 to 30 sec.
	Brake cylinder filling time In Loaded (Pressure rise from 0 to 3.6 kg/cm <sup>2</sup> )	18 to 30 sec.
4.2	Maximum brake cylinder pressure	
	a) Empty	$2.2 \pm 0.25$ kg/cm <sup>2</sup>
	b) Loaded	$3.8 \pm 0.1$ kg/cm <sup>2</sup>
4.3	Reduction in BP pressure required for full service application	1.3 to 1.6 kg/cm <sup>2</sup>
5.	Release after full service application	
5.1	Draining time (Brake cylinder pressure to fall from $2.2 + 0.25$ kg/cm <sup>2</sup> to 0.4 kg/cm <sup>2</sup> ) In Empty Condition	45 to 60 sec.
	Draining time (Brake cylinder pressure to fall from $3.8 + 0.1$ kg/cm <sup>2</sup> to 0.4 kg/cm <sup>2</sup> ) In Loaded Condition	45 to 60 sec.
6.	Sensitivity of brakes Isolate brake pipe from mainline. Check the response of brakes when the brake pipe pressure is reduced at the most equal to 0.6 kg/cm <sup>2</sup> in 6 sec.	Brake should apply within 6 sec.
7.	Insensitivity of brake. Isolate brake pipe from mainline. Check the response of brakes when brake pipe pressure is reduced at least equal to 0.3 kg./cm <sup>2</sup> in 60 seconds.	Brake should not apply.
8.	Emergency application	
8.1	Brake cylinder filling time In Empty (Pressure rise from 0 to 2.1 kg/cm <sup>2</sup> )	18 to 30 sec.
	Brake cylinder filling time In Loaded (Pressure rise from 0 to 2.1 kg/cm <sup>2</sup> )	18 to 30 sec.

8.2	Maximum brake cylinder Empty	
	a) Empty	2.2 ± 0.25 kg/cm <sup>2</sup>
	b) Loaded	3.8 ± 0.1 kg/cm <sup>2</sup>
9.	Piston stroke	
	a) Empty *	54± 10mm
10.	Leakage from brake cylinder after emergency application	0.1 kg/cm <sup>2</sup> within 5 minutes
11.	Automatic exhausting of brake cylinder and control chamber	
12.	Apply emergency brakes (i.e. BP= 0 kg/cm <sup>2</sup> ). Check the brake cylinder pressure after giving a brief pull to release hook.	Brake cylinder and control reservoirs should exhaust automatically.
13.	Empty load change over by APM Dvice	
13.1	unrestricted movement of lever arm of APM Device.	Brake cylinder pressure 2.2 ± 0.25 kg/cm <sup>2</sup>
13.2	Restrict the movement of lever arm of APM Device by more than 25 mm (by putting a block of 25 mm thickness) from its initial position.	Brake cylinder pressure 3.8 ± 0.1 kg/cm <sup>2</sup>
13.3	APM arm movement from fully retracted Position to bogie side frame top	APM Setting (A) See Table-I
13.4	Brake cylinder pressure with unrestricted movement of lever arm of APM Device.	Brake cylinder pressure 2.2 ± 0.25 kg/cm <sup>2</sup>
13.5	Restrict the movement of lever arm of APM Device with B mm block. placed on bogie frame	Brake cylinder pressure 3.8 ± 0.1 kg/cm <sup>2</sup>
13.6	Restrict the movement of lever arm of APM Device with C mm block. placed on bogie Frame	Brake cylinder pressure 3.8 ± 0.1 kg/cm <sup>2</sup>
14.	Hand Brake	
14.1	Apply hand brakes (by one person and strike All wheels with hammer)	There should not be ringing sound.

Date:

-----  
Signature & Name of testing  
Authority.

**Note:-** For APM Setting A mm, B mm block and C mm block see table- I as given below.

\* However, if in few cases, the piston stroke at empty pressure during testing on SWTR exceeds the specified range, the piston stroke is to be tested by locking the wheels with wedges.

**APM SETTING ( KNOOR BMBS SYSTEM )****TABLE-I**

S.No.	Wagon	Check	A	B	C
1	BOSTHSM2	APM arm movement from fully retracted position to bogie side frame top.	99 <sup>+1/-0</sup> mm	20mm	18mm
2	BOXNHL	APM arm movement from fully retracted position to bogie side frame top.	96 <sup>+1/-0</sup> mm	17mm	15mm
3	BCNHL	APM arm movement from fully retracted position to bogie side frame top.	96 <sup>+1/-0</sup> mm	17mm	15mm
4	BOXN NLB 20.32 T	APM arm movement from fully retracted position to bogie side frame top.	92 <sup>+1/-0</sup> mm	13mm	11mm
5	BOXN NLB 22.9 T	APM arm movement from fully retracted position to bogie side frame top.	90 <sup>+1/-0</sup> mm	11mm	9mm
6	BOXN HS 20.32 T	APM arm movement from fully retracted position to bogie side frame top.	94.5 <sup>+1/-0</sup> mm	15.5mm	13.5mm
7	BOXN HS 22.9 T	APM arm movement from fully retracted position to bogie side frame top.	94 <sup>+1/-0</sup> mm	15mm	13mm
8	BTFLN 20.32 T	APM arm movement from fully retracted position to bogie side frame top.	94 <sup>+1/-0</sup> mm	15mm	13mm
9	BOBSN	APM arm movement from fully retracted position to bogie side frame top.	88 <sup>+1/-0</sup> mm	9mm	7mm
10	BRN 22.9	APM arm movement from fully retracted position to bogie side frame top.	95.5 <sup>+1/-0</sup> mm	16.5mm	14.5mm
11	BOBRNHSM1	APM arm movement from fully retracted position to bogie side frame top.	90.5 <sup>+1/-0</sup> mm	11.5mm	9.5mm

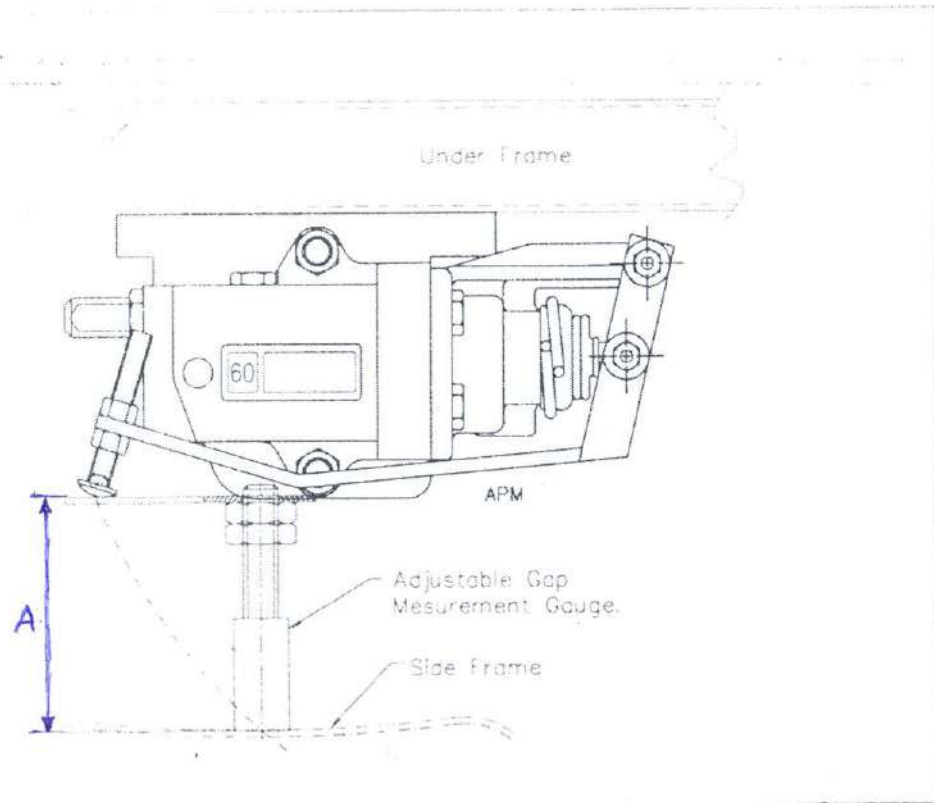
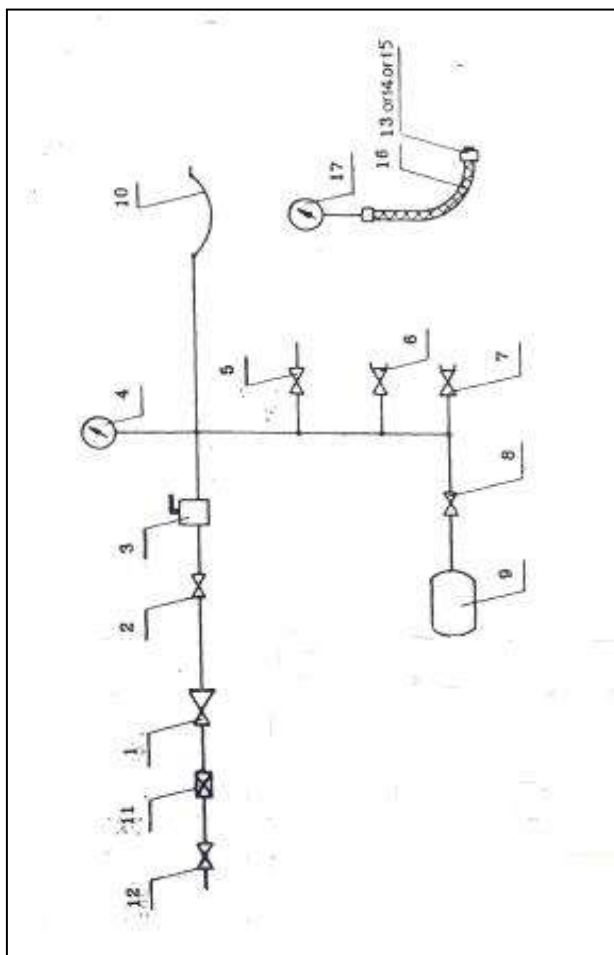


Fig.

### APM SETTING

**NOTE: Piston strokes for different types of wagons shall be as given below-**

Type of wagon	Piston Stroke	
	Empty	Loaded
BOXN, BCN/BCNA, BRN, BTPGLN	85 mm +/- 10	130 mm +/- 10
BOXNHL, BCNHL	85 mm +/- 10	120 mm +/- 10
BTPN	85 mm +/- 10	130 mm +/- 10
BOY	90 mm +/- 10	135 mm +/- 10
BVZC	70 mm +/- 10	--
BOBRN	100 mm +/- 10	110 mm +/- 10
BOBYN	100 mm +/- 10	110 mm +/- 10
BLC	95 mm +/- 10	120 mm +/- 10
BVZI	32 mm	
BOSTHS, BOBSN	85 mm +/- 10	130 mm +/- 10
ALL TYPES OF WAGON BMBS (KNORR BREMSE DESIGN)	54 mm +/- 10	--
ALL TYPES OF WAGON BMBS (ESCORTS DESIGN)	55 mm +/- 10	70 mm +/- 10



**Fig. 7.33 SINGLE WAGON TEST RIG (SWTR) (Single Pipe)**

Fig. Ref. No.	Description	Qty.
1	Pressure reducing valve	1
2	Isolating cock 15 mm	1
3	Drivers brake valve	1
4	Pressure Gauge for BP	1
5	Isolating Cock 15 mm	1
6	Isolating Cock 15 mm with choke	1
7	Isolating Cock 15 mm with choke	1
8	Isolating cock 15 mm	1
9	Air Reservoir 40 L	1
10	Flexible hose BP 1 M long	1
11	Check valve 15 mm	1
12	Isolating cock 15mm	1
13	Adapter for AR	1
14	Adapter for CR	1
15	Adapter for BC	1
16	Flexible Hose 10mmx2 m long	3
17	Pressure gauge	3
18	Trolley (Not Shown)	1

## 721. Rake Test : (Conventional Brake System and BMBS System)

### RAKE TEST RIG FOR SINGLE PIPE

A schematic layout of rake test rig (RTR) is shown in fig. 7.33 A rake consisting of 58 wagons can be tested with this rig. This rig may be used for testing the train in yard before attaching the engine.

#### Description:

The rake test rig has air supply and mobile test rig. The mobile test rig is having a cubical structure and is mounted on wheels. It can be taken to the yards and sick lines.

#### Air Supply System:

- a. This consists of a compressor (1), after cooler (2), check valve (3) main reservoir (4), safety valve (5) and filter (6). All these items are to be installed in a room in a yard.
- b. The compressor generates pneumatic pressure of 10 kg./cm<sup>2</sup> and compressed air is stored in main air reservoir MR (4). The safety valve (5) opens out if the pressure exceeds 10 kg./cm<sup>2</sup>. The oil and dirt will be separated out in the filter (6). The check valve (3) prevents back flow of air while compressor is off.
- c. The compressed air line is connected to the pipe line in the sickline/yard. Angle cock and hose couplings (BP) are provided at various points depending upon the train formation and check points in sickline.

#### Mobile Test Rig.

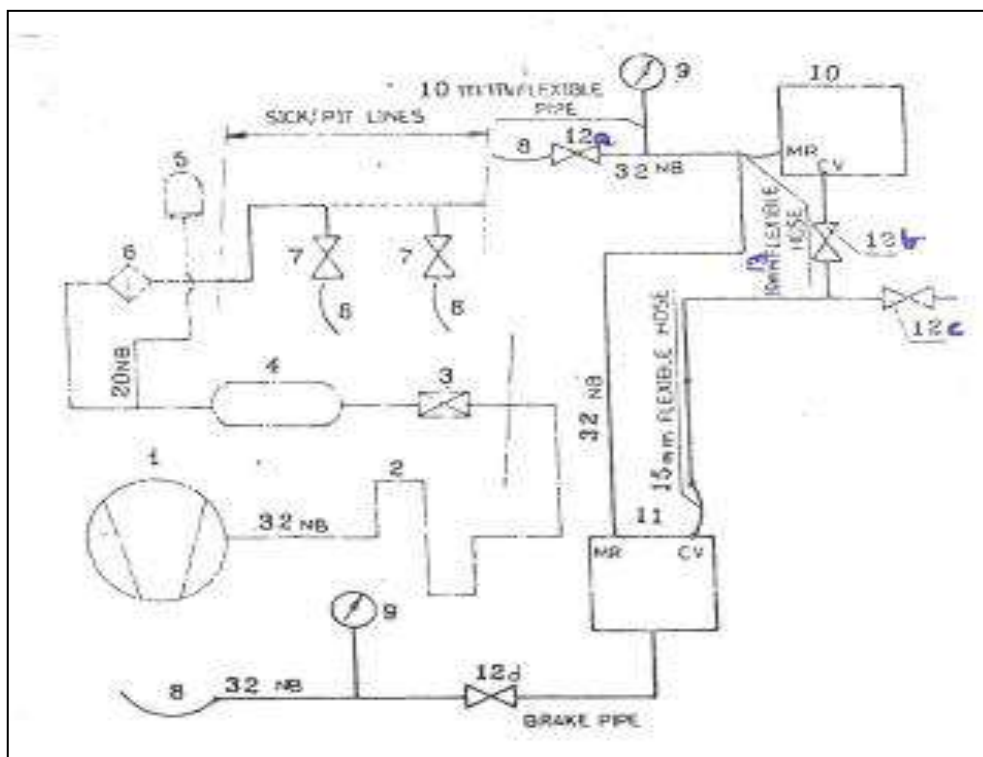
- a. The rig consists of brake hose coupling BP (8) and isolating cock (12) at the inlet of the mobile test rig. The air connection can be tapped from one of the points of sickline. The mobile test rig is provided with driver's brake valve (10).
- b. Brake pipe in the rake is charged while driver's brake valve (10) is kept in released and running position. The driver's brake valve inlet is connected to MR. It regulates the pressure to 5 kg./cm<sup>2</sup> through the relay valve (11). Isolating cock (12d) is provided to isolate BP from driver's brake valve (10).
- c. The relay valve (11) has been provided in the system for augmenting the feeding capacity of driver's brake valve.
- d. The hose coupling of BP is connected to the brake pipe coupling of the rake.

#### Testing Procedure:

Attach the rake test rig to the rake through the couplings. Carry out tests as per the procedure given in {MP guide No.11 (Rev.01) amendment No.01 of Jan-2010}

**Note:** In case rake test rig is not available testing shall be done by Locomotive.

**Fig. 7.33 (Single Pipe)**



**721-A. Rake Test :( Conventional Brake System and BMBS System)**

**Procedure of Rake Testing for Freight Stock Twin pipe:**

A schematic layout of rake test rig (RTR) is shown in Fig 7.34. A rake of wagon stock can be tested with this Test Rig. This Rig may also be used for testing the train in yards before attaching the engine.

The Rake Test Rig unit has air supply and mobile test rig. The mobile test rig is having a cubical structure and is mounted on wheels. It can be taken to the yards and sick lines. The procedure is as follows:

- A. Carry out Visual Examination of rake.
- B. Prepare Test Rig for Rake Test.
- C. Conduct Leakage, Service Application and Release Test.

Visual inspection is a check of air brake sub-assembly for any damage on the brake pipe, hose coupling etc and then rectifying it. The steps are :-

- i) Inspect loose suspension brackets and anti-pilferage devices of all air brake sub-assemblies.
- ii) Visually inspect for any defect/damage in the brake pipe, hose pipe, coupling etc.
- iii) Rectify or replace the problematic part/sub-assembly.

Rake Test can be performed by using a portable device called ‘Test Rig’ or by Locomotive. The Test Rig provides all facilities like locomotive to conduct the test. The source of



compressed air supply to the Test Rig is through a compressor installed in the wagon depot for Brake Pipe and Feed Pipe of the test rig. The Air Dryer should also be provided just before connecting brake pipe and feed pipe for supply of dry air.

#### **AIR SUPPLY SYSTEM OF RAKE TEST RIG:**

- This consists of a compressor (1), after cooler (2), check valve (3) main reservoir (4), safety valve (5) and filter (6). All these items are to be installed in a room in a yard.
- The compressor generates pneumatic pressure of 10 kg./cm<sup>2</sup> and compressed air is stored in main air reservoir MR(4). The safety valve (5) opens out if the pressure exceeds 10 Kg./cm<sup>2</sup>. The oil and dirt will be separated out in the filter (6). The check valve (3) prevents back flow of air while compressor is off.
- The compressed air line is connected to the pipe line in the sick line/yard. Angle cock and hose coupling (BP) are provided at various points depending upon the train formation and check points in sick line.

#### **MOBILE TEST RIG**

- The rig consists of brake hose coupling BP (8) and isolating cock (13) at the inlet of the mobile test rig. The air connection can be tapped from one of the points of sickline. The mobile test rig is provided with driver's brake valve (10) and an equalizing reservoir (15).
- Brake pipe in the rake is charged while driver's brake valve (10) is kept in released and running position. The driver's brake valve inlet is connected to MR. It regulates the pressure to 5 kg./cm<sup>2</sup> through the relay valve (11). Isolating cock (13) is provided to isolate BP from driver's brake valve (10).
- The relay valve has been provided in the system for augmenting the feeding capacity of driver's brake valve. The hose coupling of BP is connected to the brake pipe coupling of the rake.
- The MR line is connected to the feed valve (12) and regulatory pressure of 6 kg/cm<sup>2</sup> is obtained from the outlet. Feed pipe in the rake will be charged through feed valve (12), isolating cock (13) and brake hose coupling FP (14).

Attach the rake test rig to the rake through the couplings. Carry out following tests as per the procedure given in G-97 Annexure-XI {MP guide No.11 (Rev.01) amendment No.01 of Jan-2010} for checking capability of locomotives for Charging/Releasing of train brakes, checking of leakage in the train, checking leakage in feed pipe, brake cylinder operative percentage, and procedure to be followed at way side.

**Note: In case rake test rig is not available testing shall be done by locomotive.**

#### ***Following examination must be carried out before rake testing***

- Hand Brakes of all wagons are fully released.
- Operating handle of empty load box is in correct position i.e. 'Empty' position when wagon is empty or lightly loaded and in 'Loaded' position when wagon is loaded beyond the specified value.
- Hose couplings of brake pipe & feed pipe on consequent wagons are coupled to one another to form a continuous air passage from the locomotive to the rear end of train.
- All the angle cocks except those at the rear end of the train are kept OPEN.

- Hose coupling at the rear end of the train is placed on hose coupling support.
- Isolating cocks of Distributor Valve on all wagons are in OPEN position.

### 1. Checking of Continuity and Leakage in Rake:

- A. Attach the Diesel/Electric locomotive/Test Rig to the rake fitted with twin pipe air brake system and couple brake pipes and feed pipes. Ensure correct coupling with brake and feed pipe in a manner that there is no leakage of air from coupled joints.
- B. The coupling should be done with angle cocks in closed position.
- C. Open the angle cocks of loco after coupling feed pipe and brake pipe.
- D. Open the angle cock of the brake pipes and the feed pipes on all the wagons and check for continuity and leakage of brake pipe and feed pipe by reducing and rebuilding brake pipe and feed pipe pressure operating by A9 brake valve & angle cock fitted in feed pipe on locomotive (on wagon side) respectively. The verification should invariably to be carried out through the pressure gauges (BP& FP) provided in Guard's Brake Van.

#### Brake Pipe pressure in train (kg/cm<sup>2</sup>)

S. N.	Length of the train	RTR/Locomotive	Brake Van
1	UP TO 56 BOXN WAGONS	5.0	4.8
2	BEYOND 56 BOXN WAGONS	5.0	4.7

#### Feed Pipe pressure in train (kg/cm<sup>2</sup>)

S.N.	Length of the train	RTR/Locomotive	Brake Van
1	UP TO 56 BOXN WAGONS	6.0	5.8
2	BEYOND 56 BOXN WAGONS	6.0	5.7

**NOTE:** If the pressure is not within specified limit as given above then check for leakage in rake and correct it.

#### Leakage Rate Test:

- E. After the stabilizing pressure as given in above table, move the driver's automatic brake valve handle (A-9) towards application position to reduce brake pipe pressure from 5.0 kg/cm<sup>2</sup> to 4.0 kg/cm<sup>2</sup>.
- F. After the brake pipe pressure has been stabilized –
  - i) Close the brake pipe isolating cock provided between additional C2W Relay valve and brake pipe of the locomotive or isolating cock of Test Rig for checking BP leakage.
  - ii) Close the isolating cock provided between feed valve and feed pipe of the locomotive or isolating cock of FP for checking FP leakage.
- G. Wait for 60 sec for temperature and gauge settlement then note the drop in pressure in brake pipe & feed pipe pressure gauge in locomotive for 05 minutes.
- H. The drop in brake pipe & feed pipe pressure gauge shall not be more than **0.25 kg/cm<sup>2</sup>/min.**
- I. If the leakage rate is more than the value indicated in (H), check for excessive leakage on individual wagon as indicated below –
  1. A hissing sound would be audible at points where leakage is heavy.
  2. Once the hissing sound is heard from a particular area, pin-point the location of leakage by applying soap water solution.
  3. Use of permitted material viz. Teflon tape arresting the leakage.

- J. In case leakage is heavy and cannot be arrested, the wagon may have to be isolated/detached.
- K. In case where leakage can be arrested temporarily by tap and the nature of leakage is such that it requires attention at primary depot, clear marking on the wagon should be to draw attention of primary depot for adequate attention.
- L. In case the leakage is from the distributor valve and cannot be arrested, isolation of the wagon can be carried out by closing the distributor valve isolating cock. In such condition, clear marking should be provided on the wagon to indicate this defect to primary depot. Do not close brake pipe angle cocks under any circumstances, either for isolation of wagons or for any purpose whatsoever, except for carrying out shunting operation after which the angle cocks should again be opened to ensure continuity of brake pipe.

## **2. Service application and Release Test:**

- A. Move the driver's automatic brake valve handle (A-9) towards service brake application position and drop the value of brake pipe pressure(BP) between **1.3 to 1.6 kg/cm<sup>2</sup>**.
- B. Brake blocks of all wagons should apply after brake application and brake blocks on wagons are mating with the wheels after brake application.
- C. Check the piston stroke of all wagons, all should be within specified limit for piston strokes for different types of wagons as per given in Para 720.
- D. If the piston stroke is incorrect then, record "A" Dimension, it should be  $70 \pm 0^2$  mm in empty and loaded condition.
- E. Check all brake cylinders. Wagons with inoperative brake cylinders should be marked unfit and detached.
- F. After the release of brake, the piston of brake cylinder should fully inside and brake blocks are away from the wheels.
- G. Guard's emergency brake valve: Ensure that Guard Emergency brake valve is working properly by operating it.
- H. BPC (Brake Power Certificate): Ensure that Loco Pilot, Guard and TXR have checked the details given in the certificate and signed for its compliance.

## **3. Brake cylinder operative %:**

1. The trains originating from primary depot should have a brake cylinder operating percentage of 100% in case of CC rake. For premium rakes, minimum originating brake power percentage is 95% and for end to end rake is 90%.
2. Train examination staff should check the operative percentage by observing gripping of brake blocks on wheels.

## **4. Procedure to be followed at Way-Side Station:**

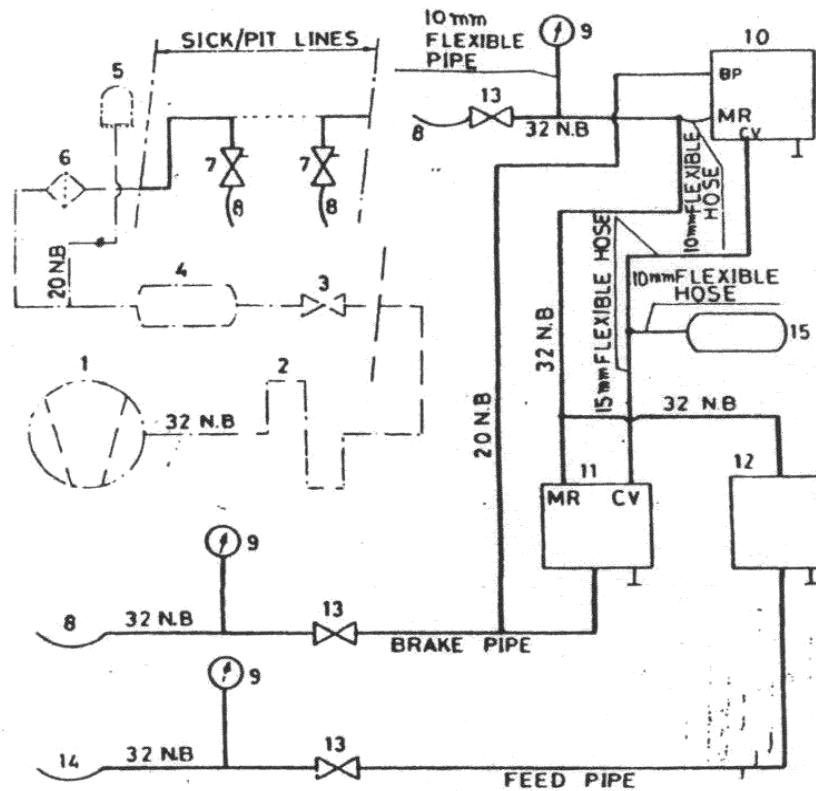
1. If the leakage rate is found more than the value indicated in 1(H), locate the source and arrest the leakage as per the procedure given in 1(I).
2. In case the leakage can be arrested temporarily by tape and the nature of leakage is such that it requires attention at primary depot, clear marking on the wagon should be done to draw the attention of primary depot for adequate attention.
3. In case the leakage is from distributor valve, follow the procedure given in 1(L).
4. In case the leakage is heavy and can not be arrested and wagon has to be detached, contact the control and obtain further advice.

**NOTE:1.** It is clarified that the maximum originating brake power for air braked goods trains running on end to end pattern of examination shall be **90%** except wherever local restrictions have specified higher levels of brake power to meet specific requirements. Exception shall only be made after prior personal approval of Chief Rolling Stock Engineer has been obtained for each individual.

**NOTE:2.** Whenever a rake is stabled, it must be secured properly as per rules given in G&SR of Zonal Railways.

<b>PROFORMA FOR RAKE TEST</b>			
<b>Type of rake :</b>			
<b>Type of Wagons :</b>			
<b>Type of DVs :</b>			
<b>BP pressure :</b>			
<b>FP pressure :</b>			
S.N.	Check	Specified	Actual
1.	<b>Pressure at last Wagon</b>		
	a) Brake pipe	Up to 56 wagons 4.8 Kg/cm <sup>2</sup> (min.) Beyond 56 wagons 4.7 Kg/cm <sup>2</sup> (min.)	
	b) Feed pipe	Up to 56 wagons 5.8 Kg/cm <sup>2</sup> (min.) Beyond 56 wagons 5.7 Kg/cm <sup>2</sup> (min.)	
2.	<b>Leakage Rate</b>		
	a) Brake pipe	0.25 Kg/cm <sup>2</sup> /min.	
	b) Feed pipe	0.25 Kg/cm <sup>2</sup> /min.	
3.	<b>Service Application and Release Test</b>		
	a) Brake application when B.P. pressure reduced between 1.3 to 1.6 Kg/cm <sup>2</sup>	Brakes should apply	
	b) Observe Piston stroke of brake cylinder	Piston in applied position and brake blocks are matting the wheels	
	c) Record the piston stroke	Piston stroke should be within specified limit.	
	d) Releasing of the brake when B.P. Pressure charge upto 5 Kg/cm <sup>2</sup>	Piston should be fully inside the brake cylinder.	
4.	Brake cylinder operating %	Trains originating from primary depot should have a brake cylinder operating percentage of 100%. <b>(In case of CC Rake)</b>	

**RAKE TEST RIG (RTR)**  
FOR TWIN PIPE AIR BRAKE SYSTEM



Note :—The equipments shown after the pit line are the parts of mobile test stand.

Item	Description	No. off	Item	Description	No. off
1.	Compressor 2000L/min. pressure 8-10 kg/cm <sup>2</sup>	1	8.	Brake hose coupling BP	2
2.	After cooler	1	9.	Single pressure gauge 6"	3
3.	Check valve	1	10.	Driver's Brake valve	1
4.	Main reservoir 300L.	1	11.	Relay valve DU-22	1
5.	Safety valve	1	12.	Feed valve F-2	1
6.	Filter	1	13.	Isolating cock	3
7.	Angle cock	2	14.	Brake hose coupling FP	1
			15.	Equalising reservoir 9L	1

**Fig. 7.34 RAKE TEST RIG**

## TOOLS AND EQUIPMENT

1. Rake Test Rig/Locomotive.
2. Open End spanner 18x19”
3. Spanner 10mm, 12mm

### 722. REPAIR AND MAINTENANCE IN SICKLINE

- i. Check for any missing component and replace them, wherever necessary.
- ii. Charge the BP pressure and check for leakage
- iii. Check whether the application and release of brakes is taking place properly. Also check for the free movement of brake rigging.
- iv. Drain the brake pipe, control reservoir and auxiliary reservoir fully and ensure that there is no pressure in the system.
- v. Remove the drain plug of auxiliary reservoir, control reservoir and centrifugal dirt collector and allow the draining of the condensate. Then charge the brake pipe and allow air to come out to the plug holes for some time so that all the dirt and other impurities may be driven out.
- vi. Remove filter housing of the common pipe bracket, clean the filter and refit making replacements, if necessary.
- vii. Remove the brake cylinder breather hole strainer, clean it and refit making replacements, wherever necessary.
- viii. Check the handles of the cut off angle cock and isolating cock are moving freely. If there is any resistance, open the assembly, overhaul it, reassemble and ensure that there is free movement.
- ix. Refer to the defects observed during checking of the arrival of the rake and make necessary rectifications.
- x. The following items on individual sub assembly to be checked :-
  - **Distributor Valve**  
Clean filter of the common pipe bracket  
Ensure ease of movement and function of quick release valve.  
Ensure valve is switched on i.e. isolating valve handle is vertically down. Ensure free movement of handle.
  - **Brake Cylinder**  
Clean the brake cylinder breather filter at regular intervals. Ensure that the piston rod is fully in.
  - **Air Reservoir.**  
Remove the condensate by opening the drain plug. Replace drain plug seal if needed.
  - **Cut off Angle Cock**  
Replace sealing ring and dowel pin, put any lubricating oil on top of handle at regular intervals. Ensure cock is open i.e. handle is parallel to the pipe.

■ **Dirt Collector**

Remove condensate by opening drain plug. Replace drain plug sealing ring, if necessary. Open the cover and clean the filter.

■ **Pipe Joints and Air brake Hose Coupling**

Replace rubber seals, if needed. Replace hose coupling assembly, if required. If there is any leakage, arrest the leakage by using appropriate sealing compound or by tightening the joints or by changing the seals as required.

- xi. Check the working of Slack adjuster and adjust “A” dimension, if required as given in para 820.
- xii. After complete maintenance of the wagons testing should be done as given in para 820.

**723. REPAIR AND MAINTENANCE DURING ROH**

- A. In routine overhaul first test the brake system using single wagon test rig as per procedure given in RDSO publication G-97 Annexure (XII) (Latest amendment). Following action should be taken for the defects/discrepancies identified during testing.
  - a) Replace DV by a DV tested in test bench if any of the following defects identified: (Ref: test proforma at Annexure-XII)
    - i. AR pressure not as specified
    - ii. CR pressure not as specified
    - iii. Maximum brake cylinder pressure in full service application/Emergency application not as specified.
    - iv. Brake cylinder filling time/draining time after full service and/or emergency application not as specified.
    - v. Insensitivity/sensitivity parameters are not as specified.
    - vi. Leakage through distributor valve.
    - vii. Brake cylinder pressures in empty & loaded condition are not within the specified limit.
  - b) Replace brake cylinder by tested brake cylinder, if following defects are identified.
    - i. Leakage from brake cylinder after emergency application is not as specified.
    - ii. If any visual damage is noticed.
  - c) Examine and repair or replace Seals/Gaskets of pipe and joint fittings if leakage rate of system is not within specified limits.
    - i) Replace the angle cock if it is leaking or damaged
    - ii) Replace leaking Guard’s Emergency Brake Valve, isolating cock, and quick coupling of brake van.
    - iii) Examine rigging/Slack Adjuster if Piston Stroke is not as specified. (See Annexure - XV & XVI of G-97)

**B. Carry out following checks and examinations.****a) Cut off Angle Cock**

Check for easy operation of cut-off angle cock. If found jammed put a few drops of light lubricating oil on top of the cock and give light hammer shocks on the top of the cock simultaneously trying to operate the handle. Operate handle 10-12 times to ensure smooth movement. If working of angle cock even after lubrication is not smooth replace by tested angle cock.

**b) Dirt Collector**

Open the drain plug and drain out the Condensate and replace the drain plug. If the leather washer is found defective it should be changed.

**c) Brake Cylinder**

Check the brake cylinder for smooth movement of piston. Lubricate the piston by injecting 2 cc of lubricating grease through the gauge point. Brake cylinder movement even after lubrication is not smooth, replace by tested brake cylinder.

**d) Auxiliary Reservoir/Control Reservoir**

Open the drain plug and drain out the condensate and replace the drain plug. If the Leather Washer is found defective it should be changed.

**e) Hose Coupling**

- i. Check serviceability of hose coupling.
- ii. Check the Gasket for any visual damage and replace if found necessary.

**f) Guard's Emergency Brake Valve**

Check easy operation of Valve. Operate 5 to 6 times. Defective valve should be replaced.

**g) Isolating Cock for BVZC Brake Vans**

Check easy operation of cock. Operate 5 to 6 times. Replace defective isolating cock.

**h) Quick Coupling for BVZC Brake Vans**

Check for proper working and replace if defective.

**i) Load Sensing Device (Fig. 4, 5, 7, 23 & 24 of G-97) for BOBR/BOBRN Wagons**

Check that wagons fitted with C3W2 OR KEO DV are provided with single piece as per RDSO drawing No. WD- 01065 – S- 01 LSD type.

- i. Check proper working of single piece load sensing device fitted on bogie. For checking the proper working of LSD in loaded condition press the piston of operating valve by inserting a bar.

**C. Ensure the following :-**

- i. Hose coupling support at both ends are fitted properly.
- ii. All mounting nuts and bolts of various equipment, pipe fitting and pipe joints are secured and tight in position.
- iii. APD of the following are as per RDSO drawings and specifications.



- (a) Angle cock
- iv) Examine and ensure that the Air Brake equipment are not physically, damaged from outside.
- D. After carrying out all the work, test the brake system in single wagon test rig for all parameters as per procedure given in Annexure XII of G-97. Rectify the defects if identified during testing. In no case wagon with brake system not meeting requirement be allowed to come out from ROH repair.
- E. Attend to special modifications, as ordered from time to time in the nominated Depots.
- F. Touch up paint and lettering where necessary.
- G. Details of replacement of DV shall be marked on the sole bar as indicated in RDSO Drg. No. WD - 93003 - S - 01.
- H. Defective equipment replaced should be taken to test bench for repair and after repair use them as spare unit for further ROH of wagons.
  - a) For the repair of Air Brake Equipment necessary spares shall be spare parts procured from approved Air Brake Supplier shall be readily available with the Depot. A maintenance kit for different equipment is given at Annexure XII of G-97. The Depot shall make assessment of the total quantity required and procure the same in Kit form. Small quantity of spares, which are not covered in maintenance kit may also be require. Such spares can be purchased as non stock item or by cash imprest.
  - b) Only used for repairs. Under no circumstances Shop made/duplicate spares shall be used. The marking on items shall be seen to verify the Supplier.
  - c) ROH Maintenance Depot should have sufficient Nos. of various spare assemblies for unit exchange.
  - d) ROH Maintenance Depot should have following Repair and Maintenance facilities for various assemblies :-
    - Facilities for opening, repair, assembly and testing of all type of DVS.
    - Facilities for Opening, Repair, Assembly and Testing of Angle cock, Dirt collector, Brake Cylinder, Isolating Cock, Guard's emergency brake valve isolating cock and quick coupling.
    - The maintenance facilities for repair of various assemblies should be similar for what has been recommended for POH.
  - e) Do not allow wagon to come out from ROH repair without APD & additional APD of DV and APD of angle cock.
  - f) After complete maintenance of the wagons testing should be done as given in para 20.

#### **724. PERIODICAL OVERHAUL OF AIR BRAKES SYSTEM**

The following procedure shall be followed for the POH of Air Brake Equipment

- i. Remove APD of DV & Angle Cocks from wagon.
- ii. Remove all assembly i.e. DV, Brake cylinder, Angle cock, Auxiliary Reservoir and Dirt Collector from Wagon.
- iii. Remove Guard's emergency brake valve, Isolating cock and quick coupling also form brake van.

- iv. Remove automatic load changeover device also from wagon in case of BOBR/BOBRN Wagons
- v. Remove pipe bracket, pipe clamps, pipe joints and strip all pipes.
- vi. The pipes should be slightly hammered to loosen the rust and scale.
- vii. After de-scaling, pipe must be blown with dry compressed air to ensure complete cleaning of rust and scale.
- viii. Clean the outside of all pipes thoroughly.
- ix. Examine all pipes for damage, cut, corrosion, etc. Damaged and heavily corroded pipe must be replaced.
- x. Examine joints for the following damage:
  - a) Sockets for cracks
  - b) Fixed Flanges for straightness
  - c) Sockets and flanges for Corrosion/damages & replace defective parts.
- xi. Replace all rubber items of pipe joints irrespective of conditions of old items.
- xii. Assemble pipe joints. Tight bolts properly and secure them by spring washer and nut.
- xiii. Fit, properly overhauled and tested, following assembly.
  - a) DV. In case new DV is fitted it should be ensured that casting tag is available on DV.
  - b) Pipe bracket
  - c) Dirt Collector
  - d) Both Angle Cocks
  - e) Brake Cylinder
  - f) Auxiliary Reservoir
  - g) Guard's emergency brake valve in case of Brake Van.
  - h) Isolating cock in case of Brake Van.
  - i) Quick Coupling in case of Brake Van.
  - j) Automatic empty load change over device in case of BOBR/BOBRN Wagons.Use new rubber items for joints between pipe and equipment irrespective of condition of old items.
- xiv Properly secure nut and bolts of joints between pipe and equipment.
- xv Examine all pipe and pipe fittings and brackets and properly secure them. Pipes should not be loose inside the pipe clamps.
- xvi Fit following APD :
  - a) APD of Angle Cock
- xvii Fit overhauled Hose Couplings at both ends of Brake Pipe.

**xviii PAINTING**

All items shall be painted black as per standard practice.

**xix. MARKING**

Besides standard marking, details shown in Drg. No. WD-93003-S-01 shall also be stencilled on the sole bar.

xx. For overhauling of various assemblies removed from wagon, follow the procedure given in various Annexures of RDSO publication No. G-97 (Latest amendment) as mentioned below :-

**xxi. TESTING OF WAGON BRAKE EQUIPMENT**

**Single Wagon Test**

This test shall be conducted on the wagon with Single Wagon Test Rig. The procedure and the specified values are given at para 720.

If the values obtained are not within the specified limits, identify the defects and rectify the defects. Single Wagon Test shall be carried out once again after rectification.

Wagons with air brake system not meeting the complete requirement of single wagon test should not be allowed to come out from POH. In case of new DV, the casting tag shall be removed after the wagon has passed the test.

**xxii PRECAUTIONS**

- a) It must be ensured that rubber items of pipe to pipe joints and pipe to equipment joint do not get damaged during fitment.
- b) It must be ensured that pipes are properly secured so that these do not vibrate on run and consequently result in leakage from joints.
- c) During assembly, it must be ensured that foreign particles or dust etc. are prevented from entering inside the pipes and equipment.
- d) It must be ensured that POH wagons coming out of workshop are fitted with hose coupling support at both ends.

**725. DETAILS OF TOOLS, FIXTURES AND EQUIPMENT**

List of tools, fixtures and equipment's with specification required to mount/dismantle the subassemblies of air brake system are as under-

<b>Sr. No</b>	<b>Description</b>	<b>Size</b>
1.	<b>General Tools :</b> Open End spanner	11-13 mm 17-19 mm 20-22 mm 24-27 mm
2.	Ring Spanners (Hexagonal or bi-Hexagonal)	17 mm, 19 mm, 32 mm, 36 mm, 37 mm, 47 mm, 57 mm, 58 mm
3.	Box Spanners	A/F 9 mm, 13 mm, 14 mm, 16 mm, 26 mm, 27 mm, 28 mm.
4.	Allen keys	A/F 5 mm, 6 mm, 8 mm, 17 mm
5.	Screw driver	6 mm blade, 3 mm blade and 10 mm blade
6.	Circlip pliers set (Internal & External)	Small, medium & large
7.	A. General Plier B. Long Nose Plier	200 mm 150 mm
8.	Socket wrenches with Driving handle 1. 'L' shaped 2. Ratchet (R&L) 3. Torque calibrated	13 mm, 17 mm, 19 mm, 22 mm, 27 mm, 32 mm & 50 mm.
9.	A. Hammer (Nylon) B. Hammer (Steel)	200 mm 150 mm
10.	Torque wrench	1.7 to 6.5 m-kg. (Range)

<b>Special Tools: KE- Type</b>	
11.	Diaphragm Tool 4A54802
12.	Adjustment Tools 4A59318
13.	Tools for Locking screw of bottom cover 3KB3349
14.	Clamping fixture or DV holding fix
15.	Wrench for Max. Limiter 4A47740
16.	Installation Tools (Assembly punch) 4A93186
17.	Thrust piece
18.	Installation hook
19.	Adjusting key
20.	Guide Tool for pin (92)

	Pressure rod (1A) sub assembly
<b>Special Tools: C3W –Type</b>	
21.	SCT6014 Two-pin tool for part no. 74
22.	SCT6016 Two-pin tool for part no. 72
23.	RPBF 0003 Holding fixture for guide 76
24.	Socket Spanner (SCT6092) 50 mm
25.	Stem leading Tool (SCT6017)
26.	Bent Tool (SCT6026) for removing air from diaphragm
27.	"O" Ring positioning (SCT 6015) Tool

**(b). DIRT COLLECTOR**

Sr.No	Description	Size
	<i>General tools :</i>	
1.	Single end spanner	A/F 27 mm
2.	Socket spanner	19, 22, 24 mm
3.	Double Ended spanner	(17-19); (22-24)
4.	DC- holding fixture or vice with semi-circular jaws	125 mm
5.	Screw driver	8 mm (Blade)

**(c). BRAKE CYLINDER**

Sr.No.	Description	Size
1.	Brake cylinder Assembly Fixture	
	<i>General Tools :</i>	
2.	Torque wrench	Torque of 200 cm-kg.
3.	Socket wrench	19 mm
4.	Ring spanner	Bi-hex (19-24)
5.	Screw driver	8 mm blade
6.	Double Ended spanner	A/F 13x14 mm, 32x36 mm

**(d). AIR RESERVOIR**

Sr.No.	Description	Size
1.	Open end spanner	A/F 28 mm A/F 22X24 (17-19) (22-24)
2.	Socket spanner	19,22 mm, 24
3.	Screw driver	8 mm Blade

**(e). CUT OFF ANGLE COCK**

<b>Sr.No.</b>	<b>Description</b>	<b>Size</b>
1.	Open end spanner	A/F 63
2.	Double open end spanner	(11-13), (17-19)
3.	Screw driver	8 mm Blade

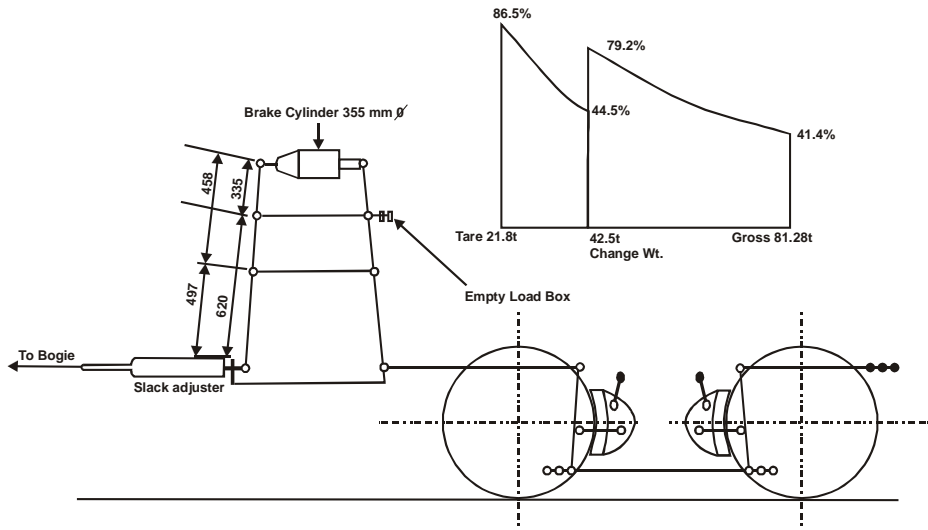
**(f). SLACK ADJUSTER**

<b>Sr.No.</b>	<b>Description</b>	<b>Size</b>
1.	Double Ended Spanner	(11-13)
2.	Special spanner (E)	
3.	Circlip plier spring type ( C ) (External)	203.2 mm to 250 mm
4.	Circlip plier bend nose type (Internal)(D)	250 mm to 304.8 mm
5.	<i>Special Tools :</i> Jacking Tool (B)	

**(g). HOSE COUPLING**

<b>Sr.No.</b>	<b>Description</b>	<b>Size</b>
1.	Pipe wrench	450 mm
2.	Open end tool	55, 65

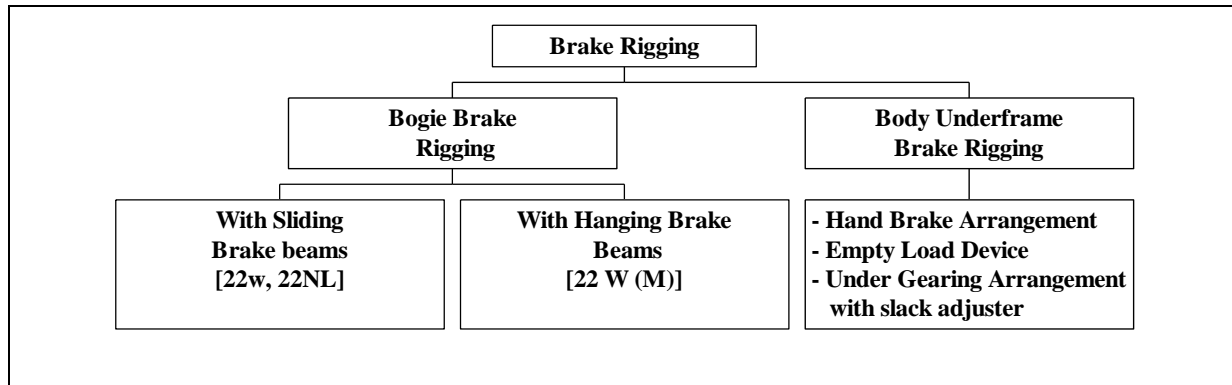
**726. BRAKE POWER CALCULATIONS FOR BOXN WAGON**



**FIG. 7.35**

**BRAKE POWER CALCULATIONS FOR BOXN WAGON**

TYPE OF BRAKE SYSTEM	= AIR BRAKE
BRAKE CYLINDER DIA	= 355 mm
NO OF CYLINDERS	= ONE
TOTAL EFFECTIVE PISTON FORCE (K) AFTER SUBTRACTION OF RESTORING SPRING FORCE AT A STROKE OF 135mm	= 3600 Kg
LEVERAGE	
	EMPTY = $\frac{335}{620} \times 12 = 6.5$
	LOADED = $\frac{458}{497} \times 12 = 11.05$
TOTAL BRAKE BLOCK PRESSURE	$P = (K i - 12Q) \eta$
RIGGING EFFICIENCY	$\eta = 0.9$
FORCE OF SLACK ADJUSTER SPRING	Q = 200 Kg
	P Empty = 18900 Kg
	P Loaded = 33642 Kg
BRAKE PERCENTAGE	$\frac{P \times 100}{\text{Tare or gross}}$
BRAKE PERCENTAGE EMPTY	= $\frac{18900}{21800} \times 100 = 86.5 \%$
BRAKE PERCENTAGE LOADED	= $\frac{33642}{21800} \times 100 = 41.4\%$
BRAKE POWER AT CHANGE WEIGHT	= $\frac{18900}{42500} \times 100 = 44.5\%$
$\frac{P(\text{TARE}) \times 100}{\text{CHANGE WT}}$	
$\frac{P(\text{GROSS}) \times 100}{\text{CHANGE WT}}$	= $\frac{33642}{42500} \times 100 = 79.2\%$

**727. BRAKE RIGGING****A. INTRODUCTION**

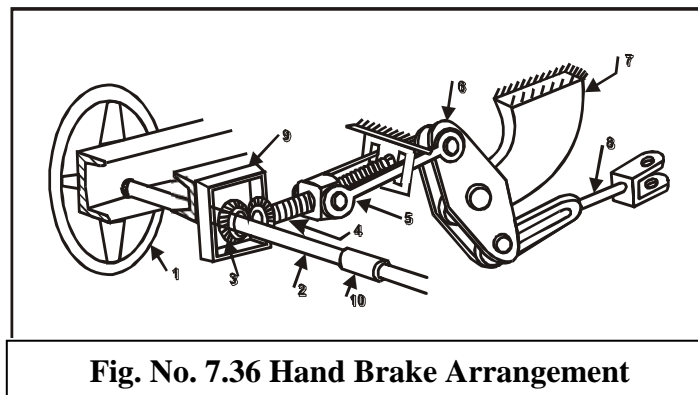
The Brake Rigging is provided to control the speed of a wagon by transferring the braking force from Brake Cylinder to wheel treads.

The Brake Rigging can be divided into two groups, as can be seen in the figure above.

**I. Hand Brake****General**

The Hand Brake provides a means of attaining retarding force with the brake shoe. The BOXN & BCN wagons are equipped with side operated Hand Brake.

However in newly designed BCNHL wagon, the hand brake wheel is on end wall portion.

**Constructional details**

**Fig. No. 7.36 Hand Brake Arrangement**

The Hand Brake arrangement consists of the following components:-

- |                                 |                                  |
|---------------------------------|----------------------------------|
| 1. Hand Brake equalising levers | 6. Hand Brake Wheel              |
| 2. Support Bracket              | 7. Hand Brake Spindle rod        |
| 3. Hand Brake pull rod          | 8. Bevel Gear set                |
| 4. Bevel gear box               | 9. Hand Brake screw rod with nut |
| 5. Sleeve for spindle.          | 10. Hand Brake connecting links  |



## II. The Empty Load device

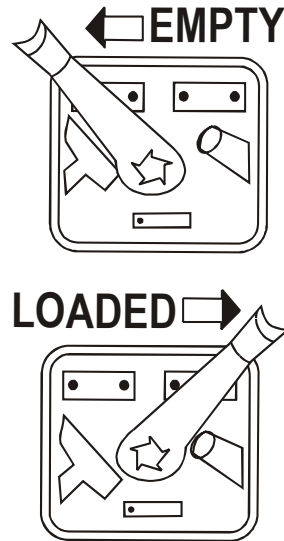
### General

The Empty Load device is provided in the Brake Rigging. It is a device by means of which lower leverage ratio for tare/empty condition and higher leverage ratio for loaded condition of the wagon can be obtained by a simple manual operation of a handle.

### Constructional details

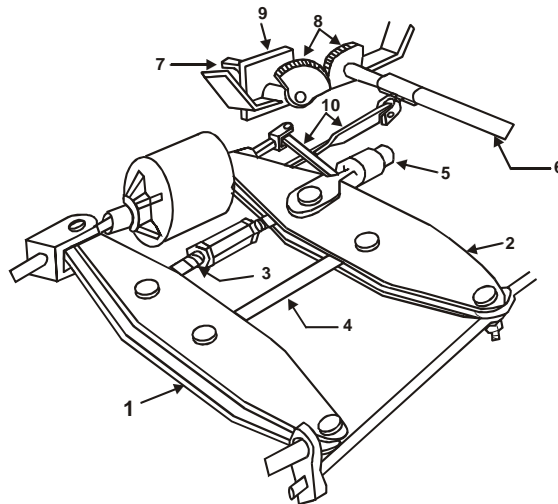
This device comprises of the followings :-

1. Horizontal lever "live'
2. Horizontal lever "dead'
3. Empty Tie rod in two pieces with sleeve nut
4. Loaded Tie rod
5. Empty load box assembly
6. Empty load shaft
7. Change over handle
8. Toothed segment
9. Sign plate
10. Connecting rods-one is plane & another is single twist
11. Bell crank and pins



**Fig. No. 7.37 EMPTY LOAD DEVICE**

The Sign Plate is painted with two colours. Half yellow (empty) and half black (loaded) portions indicate positions respectively, to which the change over handle in set.

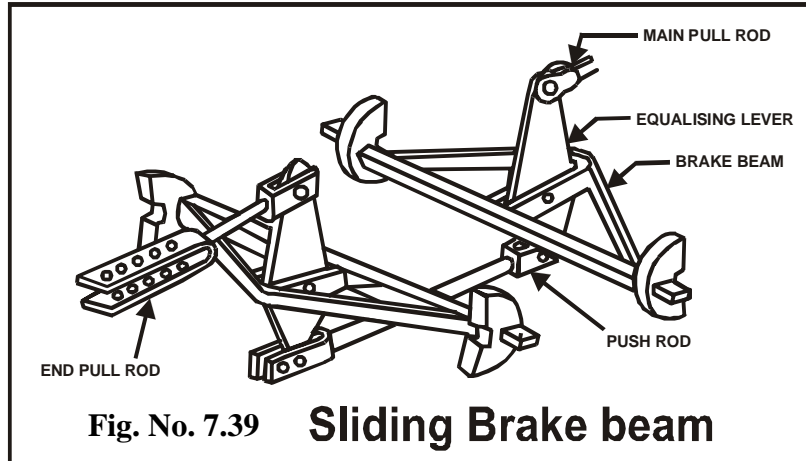


**Fig. No. 7.38 EMPTY LOAD DEVICE**

### III. Components

Depending on the brake beam arrangements, brake rigging can be of following two types.

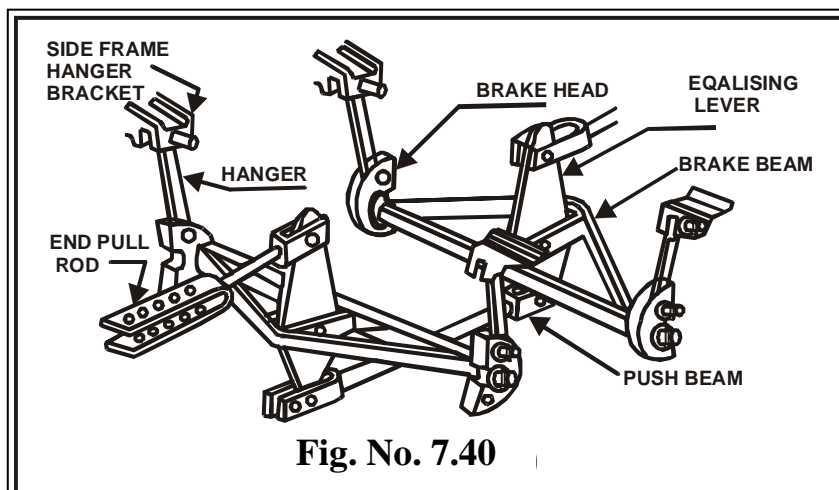
#### Sliding Brake Beam



For CASNUB 22 W, 22-NL, NLB, NLM, HS, HS (Mod- I), HS (Mod- II) & NLC bogies, the brake beam is of sliding type, having fabricated box-steel structure with integral cast steel pieces for strut & brake-heads.

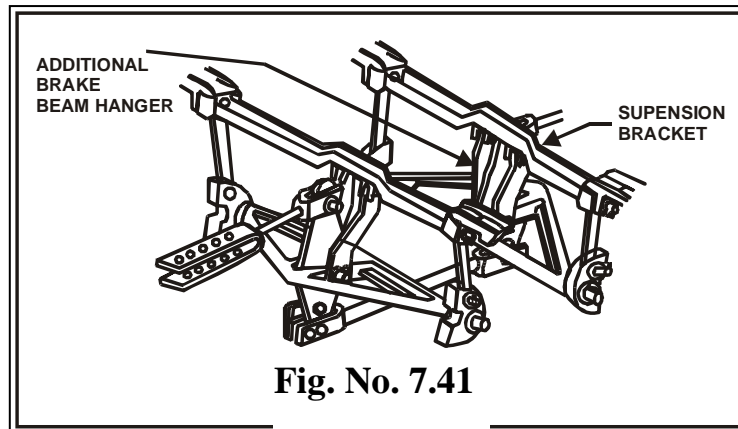
#### Hanging Type Brake Beam:-

Hanging brake beam without additional brake beam support



For CASNUB 22W(M) bogie, hanging type cast steel brake beams are provided. Brake heads and blocks are secured by key and they are further assembled with brake beams through spring loaded brake shoe adjuster.

Hanging brake beam with additional brake beam support.

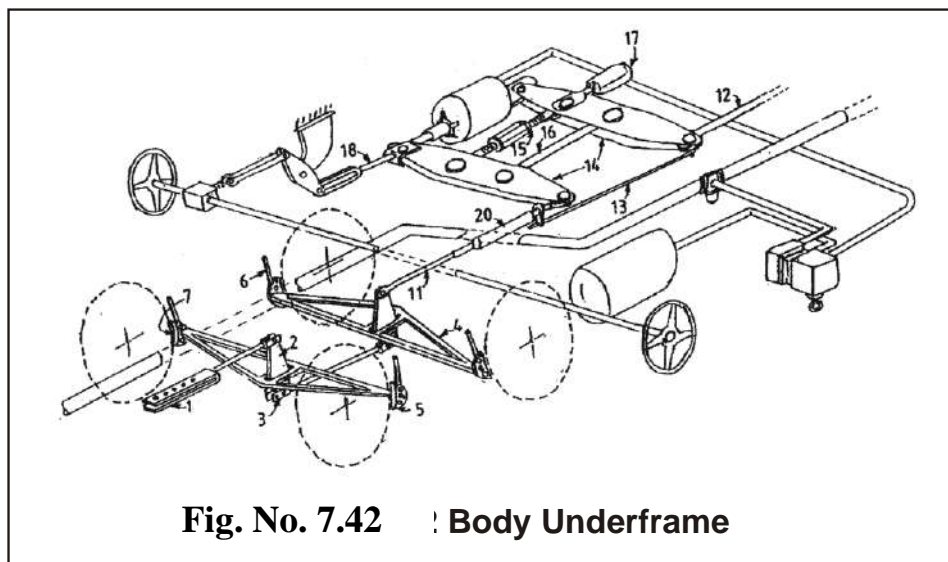


**Fig. No. 7.41**

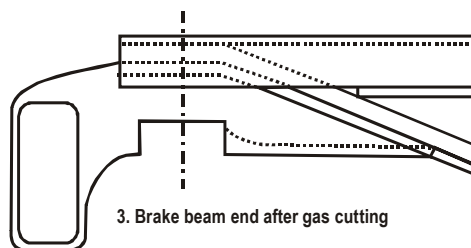
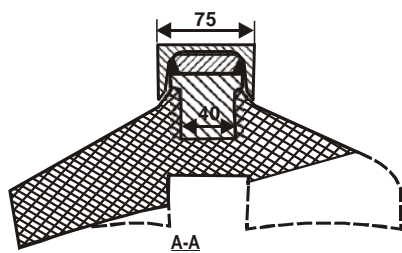
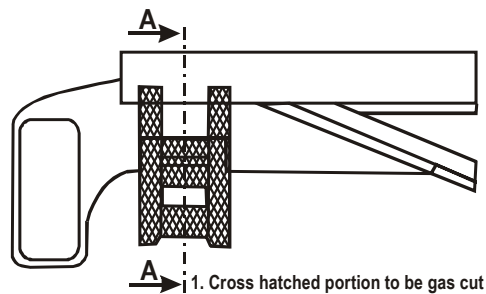
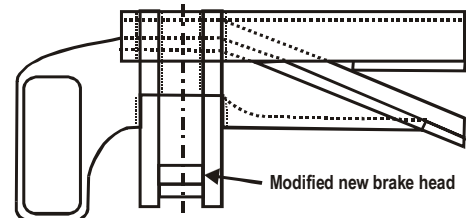
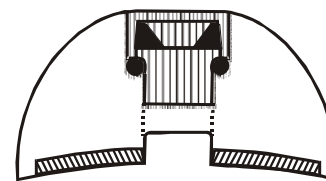
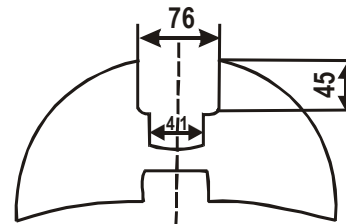
### Body Under frame Components

Details of components and assemblies used in various types of brake rigging arrangements are given below and shown in figure;

- |                                       |                                  |
|---------------------------------------|----------------------------------|
| 11. End pull rod                      | 1. Short pull rod                |
| 12. Equalising lever                  | 2. Long pull rod                 |
| 13. Push rod                          | 3. Control rod with head         |
| 14. Brake beam                        | 4. Horizontal lever              |
| 15. Brake head assembly               | 5. Empty tie rod with sleeve nut |
| 16. Brake beam hanger                 | 6. Loaded tie rod                |
| 17. Brake block                       | 7. Empty load device             |
| 18. Brake show key                    | 8. Hand brake pull rod           |
| 19. Brake wear plate                  | 9. Hand Brake arrangement        |
| 20. Brake gear pins, washers, cotters | 10. Slack Adjuster               |



**Fig. No. 7.42 : Body Underframe**

**BRAKE-HEAD REPLACEMENT****CASNUB-22NL, 22NLB, 22W, 22NLM, 22HS, 22HS (Mod-I), 22HS (Mod-II) & 22 NLC Brake Beams****Fig. No. 7.43****Fig. No. 7.44**

- a) Remove worn-out brake head. Other members, if damaged, should be built up by welding, followed by proper cleaning and finishing operation, as shown in figure to the right

- b) Weld new brake head at correct position.

**CASNUM 22W (M) Brake beam:**

- Remove split pin and washer from brake beam ends. Remove pin securing brake shoe adjuster with brake beam by removing
- Take the Brake Heads out of the Brake Beam along with Brake shoe adjuster
- Disengage brake shoe adjuster form brake head by removing bolt after disengaging split pin, nut, cover, spring and adjusting piece.
- Assemble the new brake head with brake shoe adjuster.

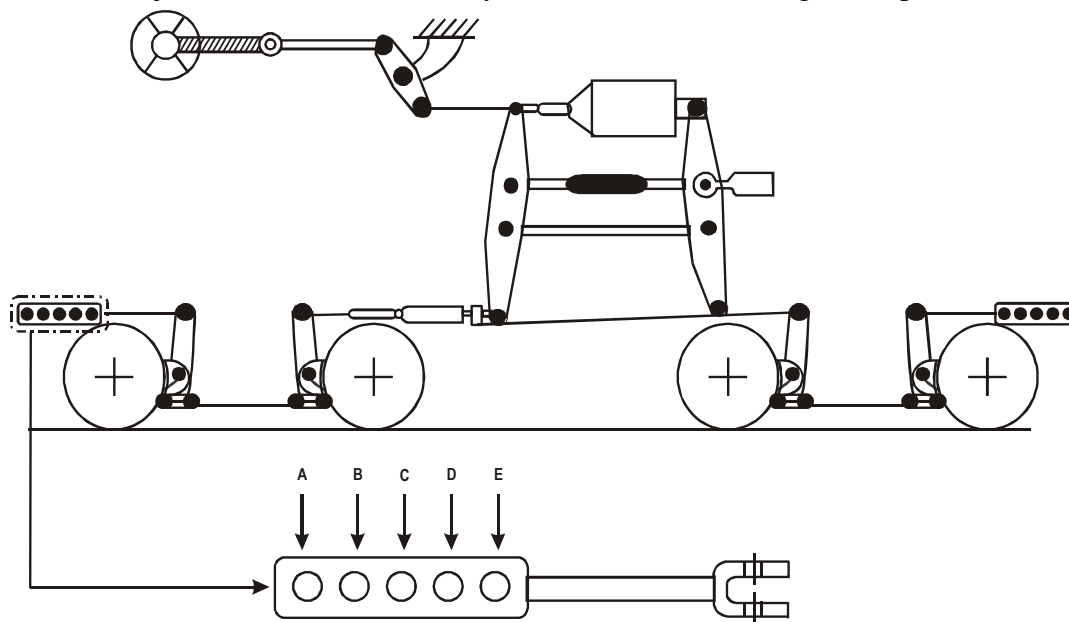
e) Secure brake heads on brake beam end by putting washer and split pin.

**Holes of end pull rod pins to be used for brake adjustment as per diameter of wheels.**

Hole	Wheel diameter on tread
A	Between 1000 & 982
B	Between 981 & 963
C	Between 962 & 944
D	Between 943 & 925
E	Between 924 & 906

The figure on next page shows where the holes are.

The push rod is provided with two holes at either end. During service, in case of wear in brake blocks, manual adjustment to outer hole may be done for maintaining brake power.



**Fig. No. 7.45**

### 728. COMPOSITION BRAKE BLOCK

Indian Railways using cast iron brake blocks for braking on freight stock. The frictional properties of cast iron brake blocks decline with the increase in speeds resulting in increased braking distance. The composition brake block has the following benefits as compared to cast iron brake blocks:-

- i) Reduced braking distance due to uniform coefficient of friction.
- ii) Reduced weight.

- iii) Longer life due to reduced wear of composition brake blocks.
- iv) Reduced noise during braking.

Initially L—type composition brake blocks were developed and tried out. After successful trials the decision was taken to progressively switch over to L- type composition brake blocks. Presently following firms are approved for regular supply of L- type composition brake blocks:-

1. M/s Rane Brake Lining, Chennai.
2. M/s BIC Auto Pvt. Ltd. Faridabad.
3. M/s Escorts Ltd., Faridabad.
4. M/s Allied Nippon
5. M/s Cemcon engineering Co. Pvt. Ltd Rohtak.
6. M/s Hindustan composites Ltd. Aurangabad.
7. M/s ILPL Mumbai
8. M/s Bony Polymers Ltd. Faridabad.
9. M/s Greysham (International) super friction Pvt. Paonta Sahib
10. M/s Sundram Brake lining Ltd. Chennai.

Cast iron brake blocks can be replaced by L- type composition brake blocks and condemning limit is the same as that of CI.

K-type composition brake blocks having higher average coefficient of friction are being developed. Moreover adoption of K-type brake block requires change in brake rigging. Development of K-type brake blocks at testing stage at present. Presently following firm are approved for regular supply of L –Type composition brake block.

1. M/s Rane Brake lining, Chennai
2. M/s BIC Auto Pvt. Ltd. Faridabad
3. M/s Hindustan composites Ltd. Aurangabad
4. M/s ILPL Mumbai
5. M/s Greysham (International) super friction Pvt. Paonta Sahib

### **Do's and Don'ts for fitment of Composition Brake Blocks**

The following procedure shall be followed to ensure proper fitment of composition brake blocks;

#### **To be done**

- i) Brake block shoe key shall be of spring steel as per RDSO drawing
- ii) Brake head shall be of spring steel as per RDSO drawing
- iii) Brake block taper should match with the wheel taper i.e. lower thickness of brake block towards flange of wheel disc and higher thickness towards other side of wheel flange
- iv) Sufficient clearance should be created by rotating the barrel of slack adjuster for fitment of brake block

- v) The brake block should be fitted from the top of wheel and pressed down so that it sits properly on brake head.
- vi) Key shall be inserted from the top and slightly hammered so that it sits properly with the brake head. Slight hammering requirements indicate that the brake shoe key is made of proper material and as per drawings.
- vii) Split pins shall be inserted through the brake head whole passing the edge of brake shoe key and ends of split pins should be bent.

**Not to be done:**

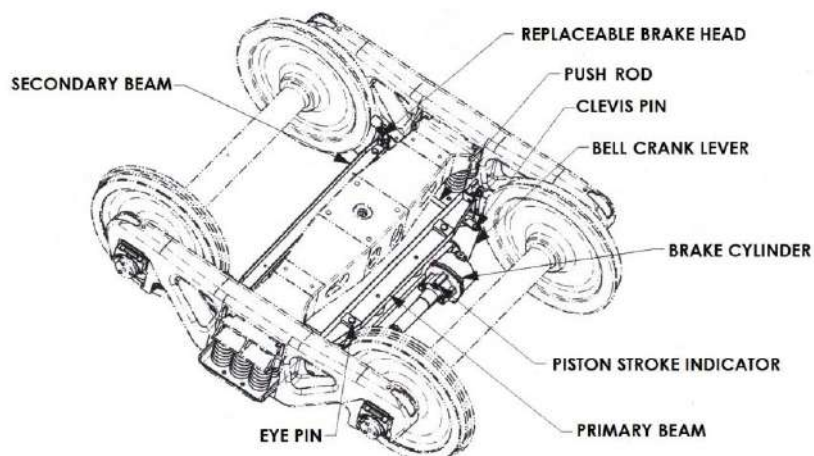
- i) No hammering should be done for fitment of brake blocks.
- ii) Brake blocks should not be dropped.
- iii) Brake blocks should be handled properly and carefully to avoid damages such as chipping / cracking.
- iv) Do not store on radius side. ( the best way is to store them on the side ways).
- v) Do not strike key if stopped by brake block nib.
- vi) Composition and cast iron brake blocks shall not be fitted on same brake beam.
- vii) Avoid fitment of composition and cast iron brake block on the same rake to get optimum wear life out of the composition brake blocks.

## 729. BOGIE MOUNTED BRAKE SYSTEM (BMBS)

### A DESCRIPTION OF BMBS

The Bogie Mounted Brake system (BMBS) equipment (Given in figure-7.46) consists of a transversely mounted pneumatic Brake Cylinder with a self-contained, double acting slack adjuster, two brake beams, two bell crank levers and interconnecting push rods. The hand brake arrangement is available as a mechanical model with two flexible handbrake cables. The pneumatic Brake Cylinder is 10" in diameter for application with high friction brake shoe (K type) on casnub type bogies. The system consists of a unique design with two pneumatic Brake Cylinder (one per bogie) to deliver reliable braking performance and is light in weight. It fits into CASNUB bogie and uses 58 mm thick brake shoes.

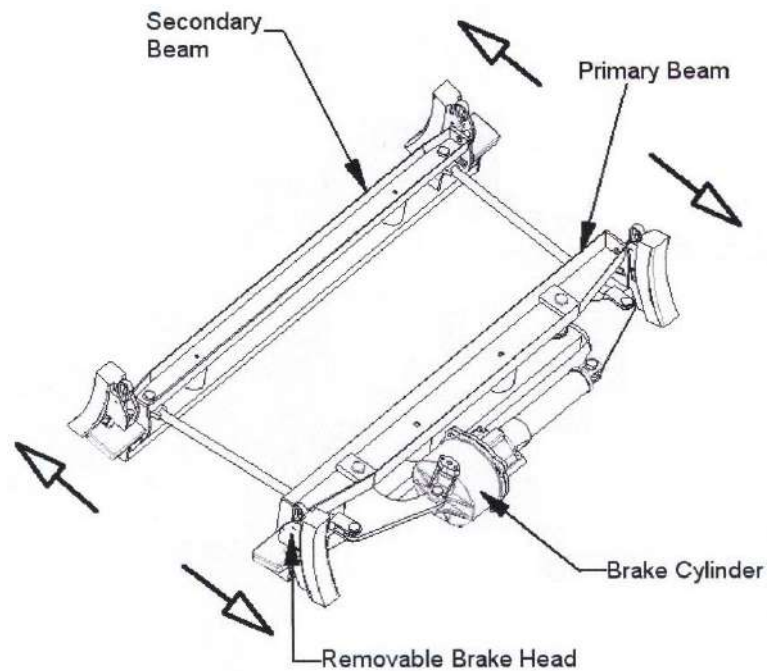
Brake cylinder contains an integral double acting slack adjuster, which provides optimal braking force and minimizes shoe & wheel wear. The design is with high strength and minimal brake beam deflection.



**FIGURE -7.46**

**B WORKING DESCRIPTION OF BMBS**

During application, the air is introduced into the brake cylinder, which forces out the piston along the ram assembly. The brake cylinder is floating in nature, as result the brake cylinder extends equally on both the sides. This extension of brake cylinder causes the rotation of the bell crank levers on their pivot (which is on primary brake beam) and forces the push rod to move towards the secondary beam. This movement causes the secondary brake beam to move towards the wheels and apply force on the wheels. Simultaneously a reaction force is developed which causes the primary brake beam (along with levers and brake cylinder) to move towards the wheels. The primary brake beam continues to move until it touches the wheels and apply force on the wheels.

**FIGURE -7.47**



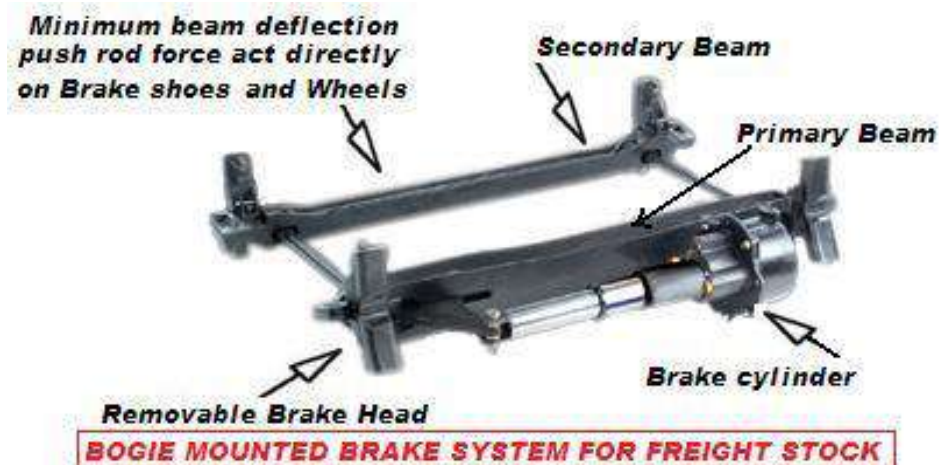


FIGURE -7.48

When the brakes are released, the air from the brake cylinder is exhausted to the atmosphere through the Distributor valve. The return spring inside the brake cylinder pushes the piston along with the ram assembly back to its original position. The bell crank levers rotate back, causing the beams to move back to their earlier positions. The brake cylinder is equipped with a double acting slack adjuster. If there is any wear (Brake Shoe/Wheel) or any slackness in the structure, it will be automatically compensated by the built in slack adjuster which pays out to fill the gap.

## C SALIENT FEATURES

### More Safety

Two nos. of 10" brake cylinders with inbuilt double acting slack adjuster have been used per wagon. Along with this an automatic load-sensing device has been used for two stage braking (empty / loaded). This delivers optimum braking performance and hence increases safety parameters.

### Reliability

Instead of one 14" cylinder, two 10" cylinders have been provided per wagon (one per bogie)., This increases the system reliability as in case of failure of one cylinder the wagon can be moved on another cylinder with the isolation of failed cylinder.

### Cost Reduction

#### a) Maintenance cost

Two cylinders are provided with inbuilt slack adjuster, re-screwing of slack adjuster is automatic and can be done from the side of the wagon by a crow bar. The system simplified installation and even shoe wear helps extend the turn round time between wagon maintenance intervals.

#### b) Fitment cost

The BMBS is drop in fit product as new brake beams are provided to slide in the existing chutes of bogie. It is very easy to assemble, no special training or tools are required for assembly.

**c) Pay load cost**

A unique design that delivers optimum braking performance while minimizing weight. With the system has reduced the tare weight of wagon..

**Easy Retro fitment**

This brake system can be easily fitted on any standard bogie without making any modifications. This is a drop in fit system and does not require any kind of modifications in the existing bogie.

**Simplified Hand Braking Installation**

In this system, hand brake is easy to install provides improved reliability and safety. There is minimum number of levers in the hand brake mechanism.

**Replaceable Brake Heads**

Improved features replaceable brake heads which do not require disassembly of the bogie for installation. This system is a direct acting system and does not require levers or reverse direction devices.

**Integral Double Acting Slack Adjuster**

Integral double acting slack adjuster maintains a constant 56mm piston stroke, resulting in uniform and efficient braking performance even as the brake shoes and wheel wear. The slack adjuster has a total make up of 500 mm, compensating for 192 mm of nominal brake shoe wear and 188 mm of nominal wheel wear.

**Patented Beam Design**

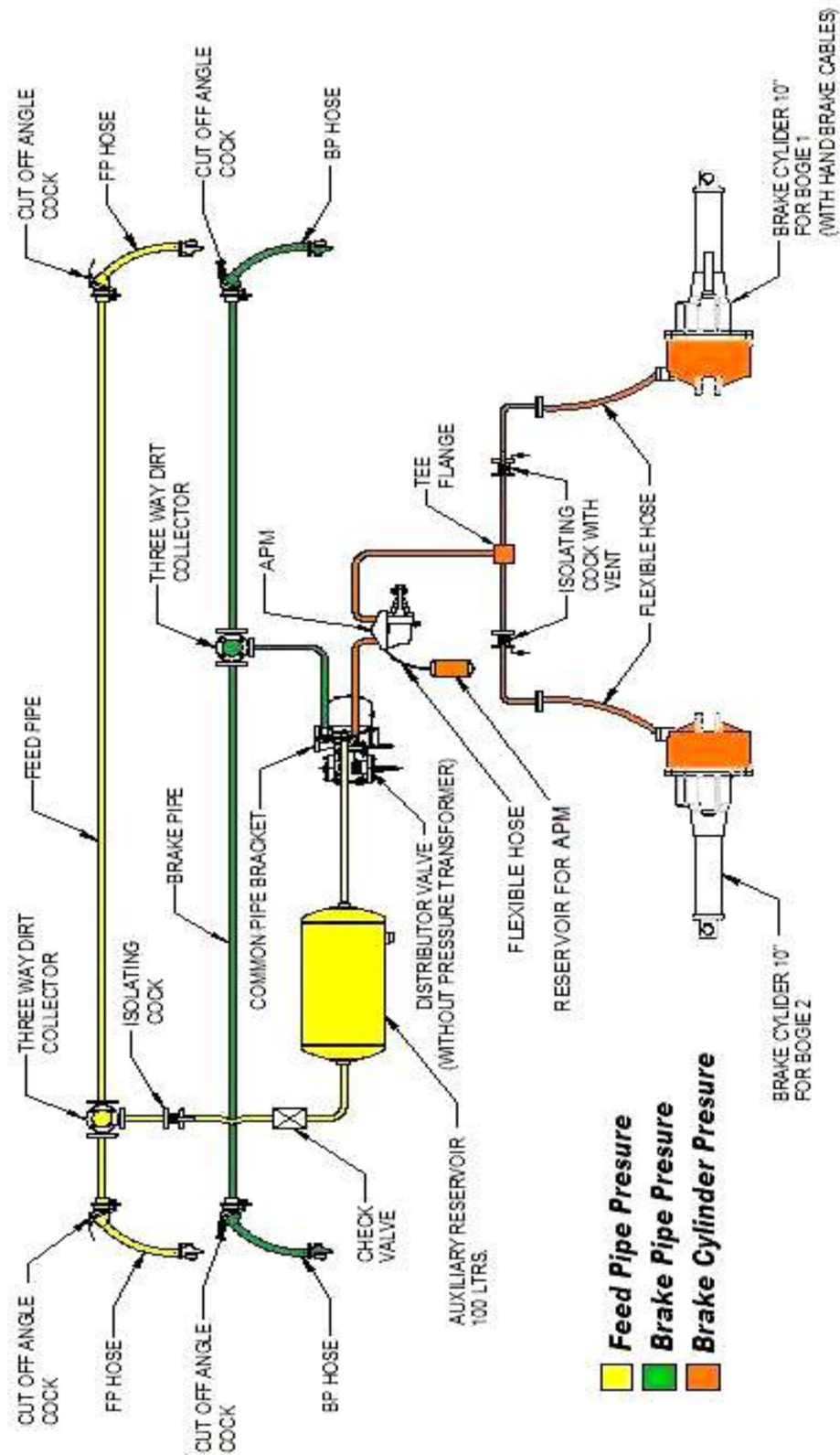
The Beam design dramatically reduces bending loads in the beams, enabling the use of lighter structure with no sacrifice in the performance. In this system, cylinder is mounted parallel to the brake beams and transfers forces through the bell cranks. This parallelogram design improves the efficiency and aligns the braking forces with the wheels, which reduces the shoe and wheel wear.

**Under Bolster Design**

In this system push rods are positioned under the bolster and can be configured to work with all bogie designs.

- ❖ BMBS is reduces bending loads in the beams, enabling the use of lighter structure with no sacrifice in the performance. The brake cylinder is mounted parallel to the brake beams and transfers forces through the bell cranks. This parallelogram design improves the efficiency and aligns the braking forces with the wheels, which reduces the shoe and wheel wear.
- ❖ The system delivers optimum braking performance while minimizing weight.
- ❖ The system can be easily fitted on any IR standard casnub bogie without making any modifications. This is a drop in fit system and does not require any special tools and training for installation/assembly.
- ❖ To achieve uniform wheel loading, the loads are applied to the ends of the brake beam instead of center.
- ❖ The system uses IR standard 58 mm thick K type brake blocks.
- ❖ A replaceable brake head design permits the reuse of the beam in the event that the brake heads gets damaged. Replacement of the brake head is quickly accomplished by removal of only one pin.
- ❖ The push rods are positioned under the bolster. With this system the track clearance has been increased, as there is nothing under the spring plank of the bogie.

- ❖ Instead of one 14" cylinder, the system uses 2 nos. of 10" brake cylinders per wagon, one per bogie. This increases the system reliability as in case of failure of one brake cylinder, the wagon can be moved on with other brake cylinder with the isolation of failed brake cylinder.
- ❖ The integral double acting slack adjuster of the brake cylinder maintains a constant piston stroke resulting in uniform brake performance even as the brake shoes and wheels wear. The slack adjuster has a total make-up capacity of 500 mm, which will compensate for total combination of shoe wear, wheel wear and clearance.
- ❖ Re-screwing of slack adjuster is automatic and can be done from the side of the wagon by a pry bar.
- ❖ All cylinders are equipped with an automatic piston stroke indicator.
- ❖ The hand brake systems uses two steel hand brake cables pulled through standard hand brake rigging as a means to apply the hand brakes. The cables provide a flexible and lightweight interface to the hand brake actuator.
- ❖ Simplified installation and even shoe wear helps extend the turn round time between wagon maintenance intervals.
- ❖ The system also has an automatic pressure modification (APM) device for two stage braking (empty / loaded). It is fitted between wagon under frame and the bogie side frame.



**FIG.7.49. LAYOUT OF TWIN PIPE AIR BRAKE SYSTEM (BMBS)**

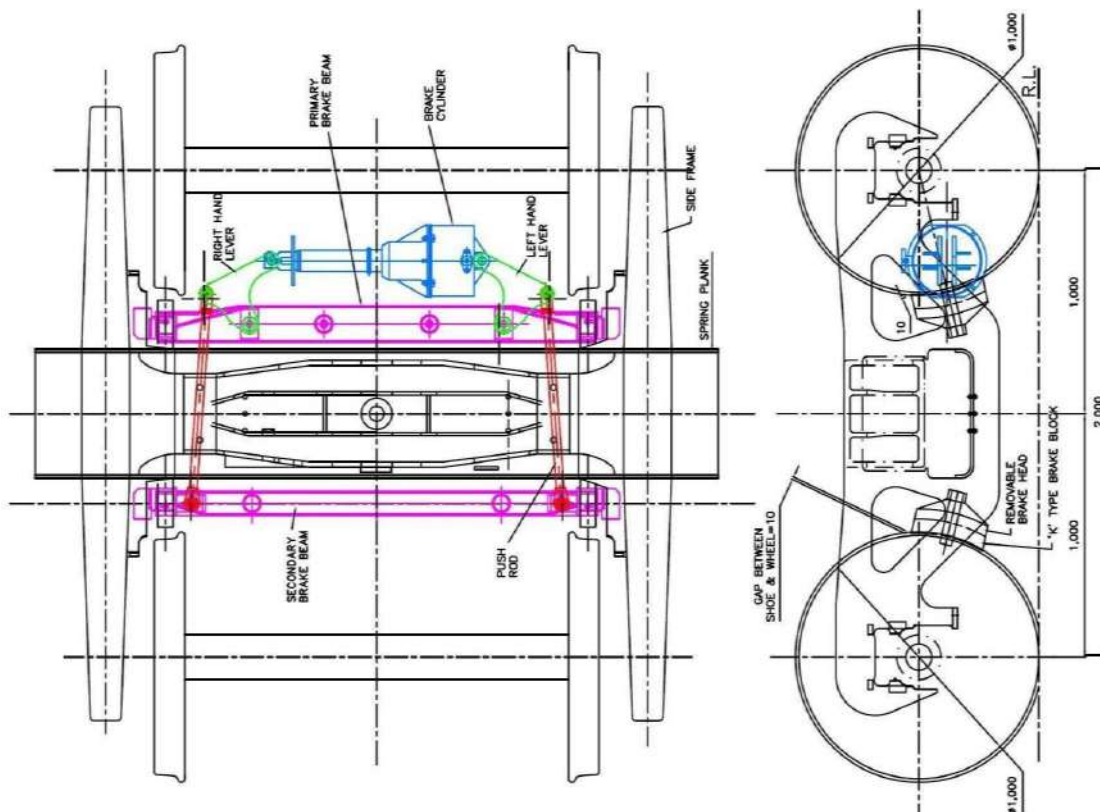
## D WORKING PRINCIPLE OF BMBS HAVING APM VALVE

The brake system provided on the wagons with BMBS is single / twin pipe graduated release system with automatic two stage braking. Its operating principle is as follows.

Schematic layout of single / twin pipe graduated release air brake system as provided on the wagons is shown in figures 7.1 & 7.49. Brake pipe / Feed pipe runs through the length of wagon. Brake pipes / Feed pipes on consecutive wagons in a train are coupled to one another by means of hose coupling to form a continuous air passage from the locomotive to the rear end of the train. Brake pipe is charged to  $5 \text{ kg/cm}^2$  through the compressor of the locomotive. Brake pipe is charged to  $5 \text{ kg/cm}^2$  through the compressor of the locomotive. Feed pipe is charged to  $6 \text{ kg/cm}^2$ .

The wagons are, provided with Automatic pressure modification (APM) device to cater for higher brake power in loaded condition instead of the conventional manual empty load device. With the provision of this, brake cylinder pressure of  $2.2 \pm 0.25 \text{ kg/cm}^2$  is obtained in empty condition and  $3.8 \pm 0.1 \text{ kg/cm}^2$  is obtained in the loaded condition.

To obtain this a change over mechanism, APM under-frame and side frame of the bogie. The mechanism gets actuated at a pre-determined change over weight of the wagon and changes the pressure going to the brake cylinder from  $2.2 \pm 0.25 \text{ kg/cm}^2$  to  $3.8 \pm 0.1 \text{ kg/cm}^2$  in case of changeover from empty to loaded and vice versa



**FIG. 7.50. DIAGRAM OF BOGIE FITTED WITH BMBS**

For application of brake, air pressure in the brake pipe is reduced by venting it to the atmosphere from driver's brake valve in the locomotive. The reduction of the brake pipe pressure, positions the distributor valve in such a way that the auxiliary reservoir is connected to the brake cylinder through the APM device and thereby applying the brake. The distributor valve gives an output pressure of  $3.8 \text{ kg/cm}^2$  for the brake cylinder which is routed through the APM device. Based on the position of sensor arm of APM device, it gives an output of  $2.2 \pm 0.25 \text{ kg/cm}^2$  for empty position braking and an output of  $3.8 \pm 0.1 \text{ kg/cm}^2$  for loaded position braking in the wagon.

During full service brake application, a reduction of  $1.3$  to  $1.6 \text{ kg/cm}^2$  takes, a maximum brake cylinder pressure of  $3.8 \pm 0.1 \text{ kg/cm}^2$  in loaded condition and  $2.2 \pm 0.25 \text{ kg/cm}^2$  in empty condition is achieved. Any further reduction of brake pipe pressure has no effect on the brake cylinder pressure. During emergency brake application, the brake pipe is vented to atmosphere very quickly; as a result the distributor valve acquires the full application position also at a faster rate. This result in quicker built up of brake cylinder pressure but the maximum brake cylinder pressure will be the same as that obtained during a full service brake application.

For release of brakes, air pressure in the brake pipe is increased through driver's brake valve. The increase in the brake pipe pressure results in exhausting the brake cylinder pressure through the Distributor valve. The decrease in the brake cylinder pressure corresponds to the increase in the brake pipe pressure. When the brake pipe pressure reaches  $5 \text{ kg/cm}^2$ , the brake cylinder pressure exhausts completely and the brakes are completely released.

## **E EQUIPMENTS DESCRIPTION OF BMBS**

### **Distributor Valve with Common Pipe Bracket and Control Reservoir**

The distributor valve assembly consists of distributor valve, common pipe bracket, adapter, control reservoir and gasket. All pipe connection to distributor valve is through the common pipe bracket. The distributor valve along with the adapter can be removed from the pipe bracket without disturbing the pipe connection for maintenance purpose.

The control reservoir of 6 litres volume is directly mounted to the pipe bracket. An isolating cock (R-charger handle) is provided on the distributor valve to isolate the distributor valve when found defective. The handle of the R-charger will be placed in vertical position when the distributor valve is in open position and horizontal when the distributor valve in closed position. A manual release handle is provided at the bottom of the distributor valve by which the brake in a particular wagon can be released manually by pulling the handle.

The distributor valve used with bogie mounted brake system has a different set of Application & Release chokes to achieve the timings as specified in the RDSO specification 02-ABR. The choke sizes to be used for Distributor valve fitted on wagons with BMBS for KE Version of distributor valve are 1.42 mm for Application & 1.52 mm for release. The other makes of distributor valves should be adopted with suitable choke sizes to achieve Brake Application & release timings as specified in 02ABR but with a stroke of 110 mm of 14" Brake Cylinder. For identification, the Distributor Valve is equipped with a name plate " BMBS " on choke cover.

### Brake Cylinder with built-in Double acting Slack Adjuster

The brake cylinder receives pneumatic pressure from auxiliary reservoir after being regulated through the distributor valve and APM device. Brake cylinder develops mechanical brake power by outward movement of its piston with ram assembly.

The piston rod assembly is connected to the brake shoes through a system of rigging arrangement to amplify and transmit the brake power. The compression spring provided in the brake cylinder brings back the ram thus the rigging is also brought to its original position when brake is released.



**FIG. 7.51. BRAKE CYLINDER - 10" DIA.**

The built-in slack adjuster compensates for the wear of brake blocks during the brake application through equivalent pay-out. For paying-in, a pry bar is applied between the brake shoe and wheel and the rigging is pushed in.

The brake cylinder has got a double acting slack adjuster as a result the actuator of brake cylinder will continue to move out till all the slack in the system is take care off and reaction force of the wheels is encountered. This ensures that every time every time the brake application takes place, sufficient brake force is delivered on the wheels.

The brake cylinder compensates for any change in gap between brake block and wheel through the inbuilt slack adjuster. Therefore it maintains a constant gap between the shoe and wheel and hence a constant piston strike. The slack adjuster works in both the condition whether there is an increase or decrease in gap. Since the brake cylinder maintains a constant piston stroke, there is no need to measure the piston stroke time and again.

There is an indicator on the brake cylinder to show the "APPLIED" or "RELEASED" condition of the Brake Cylinder. Don't hit the indicator, it may retract slowly. Hitting can bend / damage the indicator.

The brake cylinder has slack adjustment of 500 mm which could compensate of brake block wear of 48 mm (From 58 to 10 mm) and wheel wear of 47 mm (i.e., wheel dia reduce from 1000 mm to 906 mm).

The brake cylinders used on the bogie mounted brake system are of two types; with hand brake cables and without hand brake cables. The brake cylinder with hand brake cables are used for interface with the hand brake arrangement on the wagons.

### APM Device

APM device is interposed between bogie side frame of casnub bogie and the under frame of the wagon. It is fitted for achieving 2-stage load braking with automatic changeover of brake power. Only one APM is required per wagon. It restricts the brake cylinder pressure coming from the Distributor valve to  $2.2 \pm 0.25 \text{ kg/cm}^2$  in empty condition of the wagon and allows the brake cylinder pressure of  $3.8 \pm 0.1 \text{ kg/cm}^2$  in loaded condition of the wagon. The sensor arm of the APM device comes down for sensing only during the brake application.



**FIGURE: 7.52- APM DEVICE (E1-50 VALVE)**

The complete movement of the sensor point is 104 mm. The first 80 mm of the sensor point is for the loaded zone and the balance is for the empty zone. The deflection of the bogie from tare to changeover weight is added to 80 mm to arrive at the total movement of the sensor point to be adjusted on the wagon. The gap between the sensor point and the bogie is to be measured at the point it touches the top surface of the side frame. Also ensure that the sensor point touches in the middle of the side frame.

It has an indicator to show the empty or loaded position. Whenever the indication is "ON" i.e., it is showing the orange colour, it is indicating the empty condition with brake cylinder pressure of  $2.2 \pm 0.25 \text{ kg/cm}^2$ . When there is no indication in the indicator, it is loaded condition with  $3.8 \pm 0.1 \text{ kg/cm}^2$  going to the brake cylinder. It has a quick connect socket to connect the gauge to the check the pressure through the pressure gauge.



### **Auxiliary Reservoir**

An auxiliary reservoir of 100 litres is provided on each wagon to store compressed air. It is charged to 5 Kg/cm<sup>2</sup> pressure through the distributor valve in case of single pipe system. However in case of twin pipe system, it is charged to 6 Kg/cm<sup>2</sup> through the feed pipe.

The auxiliary reservoir is made out of sheet metal. On both the ends of the reservoir, flanges are provided for pipe connection. One end of the reservoir is kept blanked for operation with single pipe brake system. A drain plug is provided at the bottom of the reservoir for draining the condensate.

### **Cut-Off Angle Cock**

Cut off angle cocks are provided at the ends of brake pipe / feed pipe on each wagon. These cocks are closed at the time of uncoupling of wagons. The vent provided in the cock facilitates easy uncoupling of hose coupling by venting the air trapped in the hose coupling when the cock is closed. The handle of angle cock is spring loaded having a self locking type of arrangement to avoid any inadvertent movement from open to close position or vice versa. The handle has to be lifted to operate the angle cock. When the handle is parallel to the pipe the cock is in open position and when at right angles to the pipe it is in closed position.

### **Hose Coupling for Brake / Feed pipe**

The hose couplings are provided to connect brake pipeline & feed pipe line throughout the train. It consists of rubber hose connected to coupling head and nipple by "Band it" type of clamps. The nipple goes into the angle cock and the coupling heads are coupled together. Rubber gasket is used in the coupling head to make the joint leak proof.

### **Dirt Collector**

Dirt collector is provided at the junction of the main brake pipe and branch pipe. This is meant for removing dust from the air prior to entering the distributor valve. This is achieved by centrifugal action.

### **Isolating Cock**

Isolating cock without vent is provided in the FP line of the twin pipe wagons. The isolating cock is used to isolate the FP pressure to the Auxiliary reservoir. The isolating cocks are OLP type meaning that when the handle is parallel to the body, it is an open position for the cock.

### **Isolating Cock with vent**

Isolating cocks with vent are provided in BC lines for isolating the mal-functioning brake cylinders on the wagon. The vent side of the isolating cock is to be maintained towards the brake cylinders in order to exhaust the pressure from the brake cylinder whenever the need arise. The isolating cocks are OLP type meaning that when the handle is parallel to the body, it is an open position for the cock.

**Pipes**

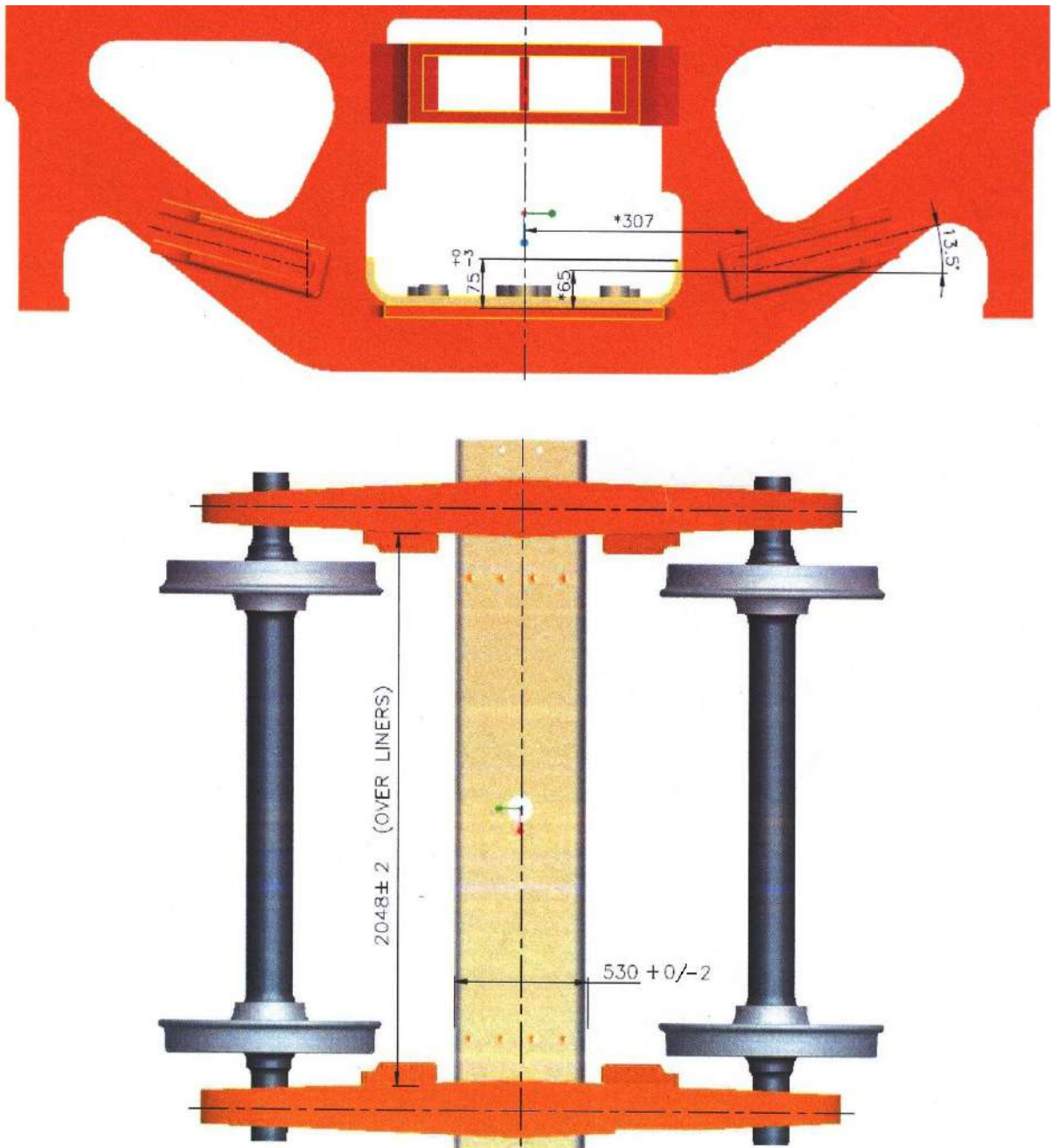
ERW stainless steel pipes as per ROSO specification 04-ABR is used for wagons with Bogie Mounted Brake System. Pipes of 32 mm & 20 mm nominal bore are generally employed. The pipes are cold bend with the help of bending equipment. The radius of the bends is to be kept to the maximum possible so as to reduce restriction of air flow.

**Pipe fittings**

Welded and swivel flange fittings are used for pipe joints. Fixed flanges are rigidly welded to pipes; whereas the Swivel flanges are used to align to the fixed locations. Rubber gaskets are used to seal the joints.

**F CRITICAL BOGIE DIMENSION FOR FITMENT OF BMBS**

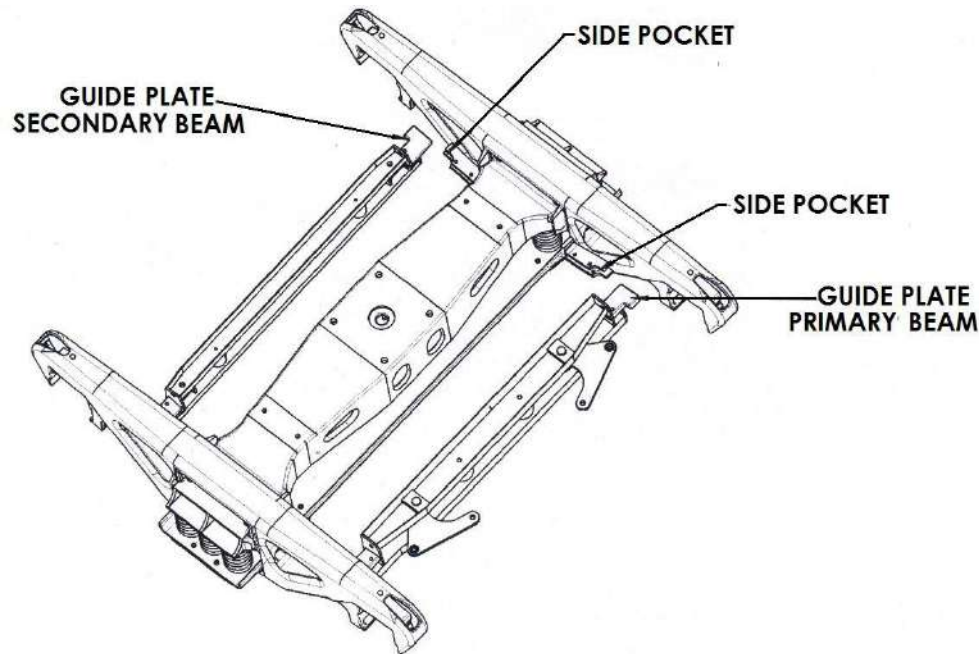
In order to ensure trouble free fitment of the Bogie mounted brake system, it is necessary that the following Bogie dimension are checked and maintained before fitment.



**FIGURE: 7.53- CRITICAL BOGIE DIMENSION**

**G PROCEDURE FOR INSTALLATION OF BMBS ON CASNUB BOGIE****Installation Procedure:**

Refer for Installation of Equipment and its adjustments;



**FIGURE: 7.54**

**Tools Required**

- i. Pry Bar
- ii. Pliers

1. To install the beams it is necessary to split the bogie. Lift the bolster and move the axles with wheels outside the side frame. Slide the primary beam assembly 1A inside the side pockets in the side frame. Place the bell crank levers 10 & 18, as per their respective position on the primary beam assembly 1A. Push the Pin 19 through the beam 1 A and bell crank levers 10 & 18. Bend the Cotter pin 23 after inserting inside the Pin 19. Slide the secondary beam assembly 1 B inside the side pockets on the other side.
2. Install the push rods 3 between the bell cranks and the secondary beam 1 B. Secure the push rods to the secondary beam with the pin 4 and cotter pin 6.
3. Secure the push rod 3 with bell crank levers with pin 5 and cotter pin 6 on primary beam sides.
4. Attach the Brake Cylinder 11 to the bell crank levers with two sets of pins 4, bush 25 and dowel sleeve 24 after aligning the mounting holes in the brake cylinder and the bell crank levers.

**Note**

- ❖ Air connection flange and Ram of brake cylinder 11 to be oriented / fitted as per the Air Brake Equipment and Under Frame Gear Arrangement drawings. Cylinder with hand brake is to be installed considering the location of Bracket 16.

- ❖ Brake cylinder 11 ram should be in fully retracted position prior to installation.
- 5. Place the brake heads 7 on the guide plates of the brake beams 1A & 1 B. Secure the brake heads to brake beams with pin 8 and lock the same with cotter pin 9.
- 6. Assemble the bogie by lowering the bolster with side frame on the axle and wheel assembly.
- 7. Install new 58mm K-type brake shoe to beam assemblies (1A & 1B) on brake heads 7. Insert brake block keys 21 to hold brake blocks to the removable brake heads.
- 8. Connect air hose from BC pipe line to the flange on top of cylinder 11.

#### **For Brake cylinders with Hand Brake Cables**

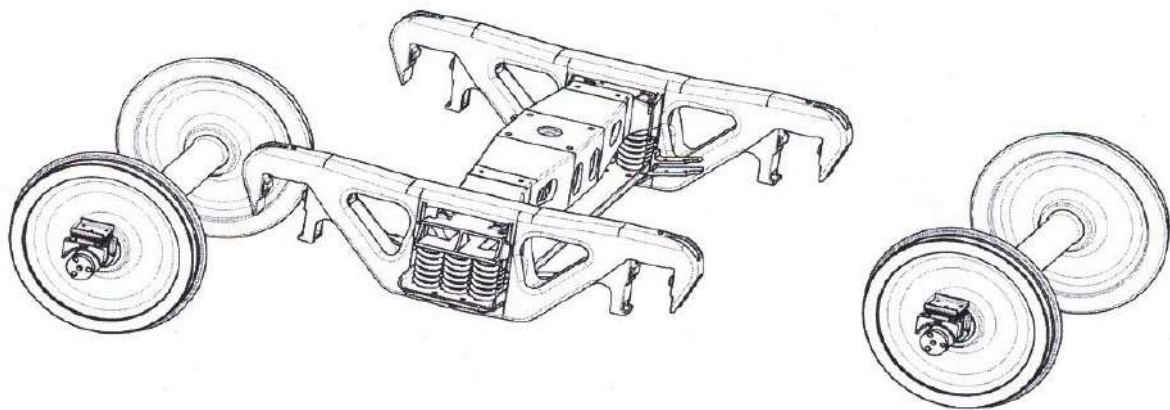
- 9. Bracket for cable end support is welded to a convenient place on the under frame of the wagon such that the bend radius of the cables is not less than 255 mm. (Refer under frame equipment installation drawings of the concerned wagon).
- 10. Attach the cable conduits to the bracket 16 by placing one nut and one washer on each side of bracket 16.
- 11. Tighten the lock nut to secure the cables to the bracket properly.
- 12. Connect both cables 13 to the cable equalizer 17 using pins 14 and cotter pins 15.
- 13. Connect air hose from BC pipe line to the flange on top of cylinder 11.

#### **Hand brake rigging**

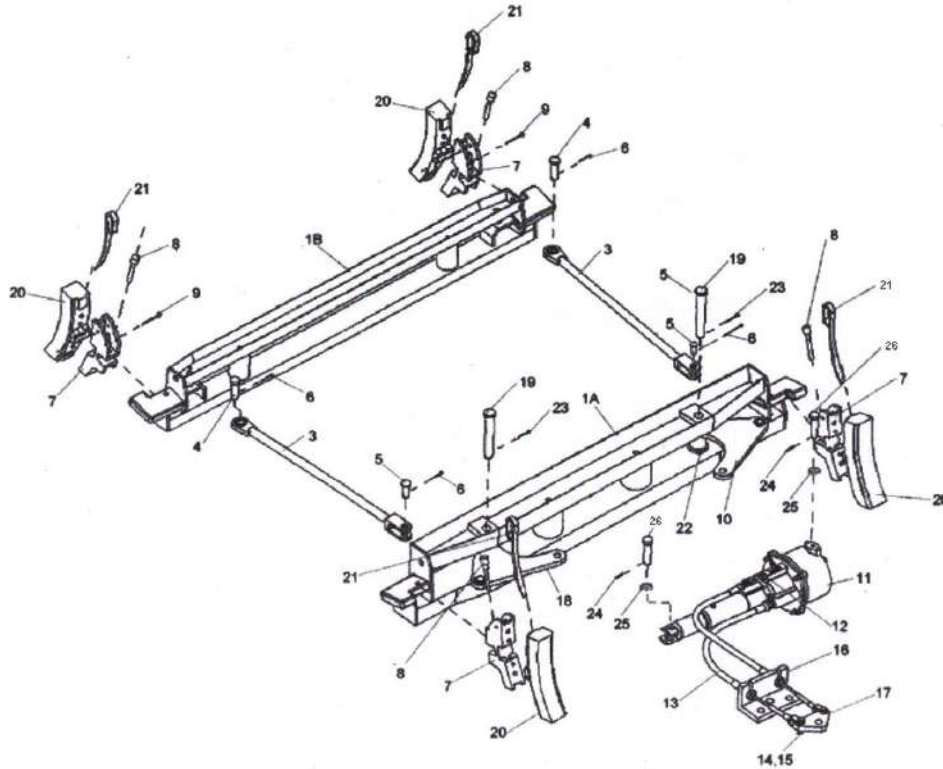
- 14. Handbrake system requires a set of rigging between equalizer 17 and the handbrake wheel as per requirement of particular type of wagon.
- 15. Apply brakes, 2-3 times to the brake cylinder 11 to ensure correct piston stroke is achieved. Release air pressure.

#### **Warning**

*To avoid personal injury from movement of the various parts when operating the system, all personnel must be clear of Bogie and Brake pads before the cylinder is pressurized.*



**FIGURE: 7.55**



**FIGURE: 7.56**

**Adjustments**

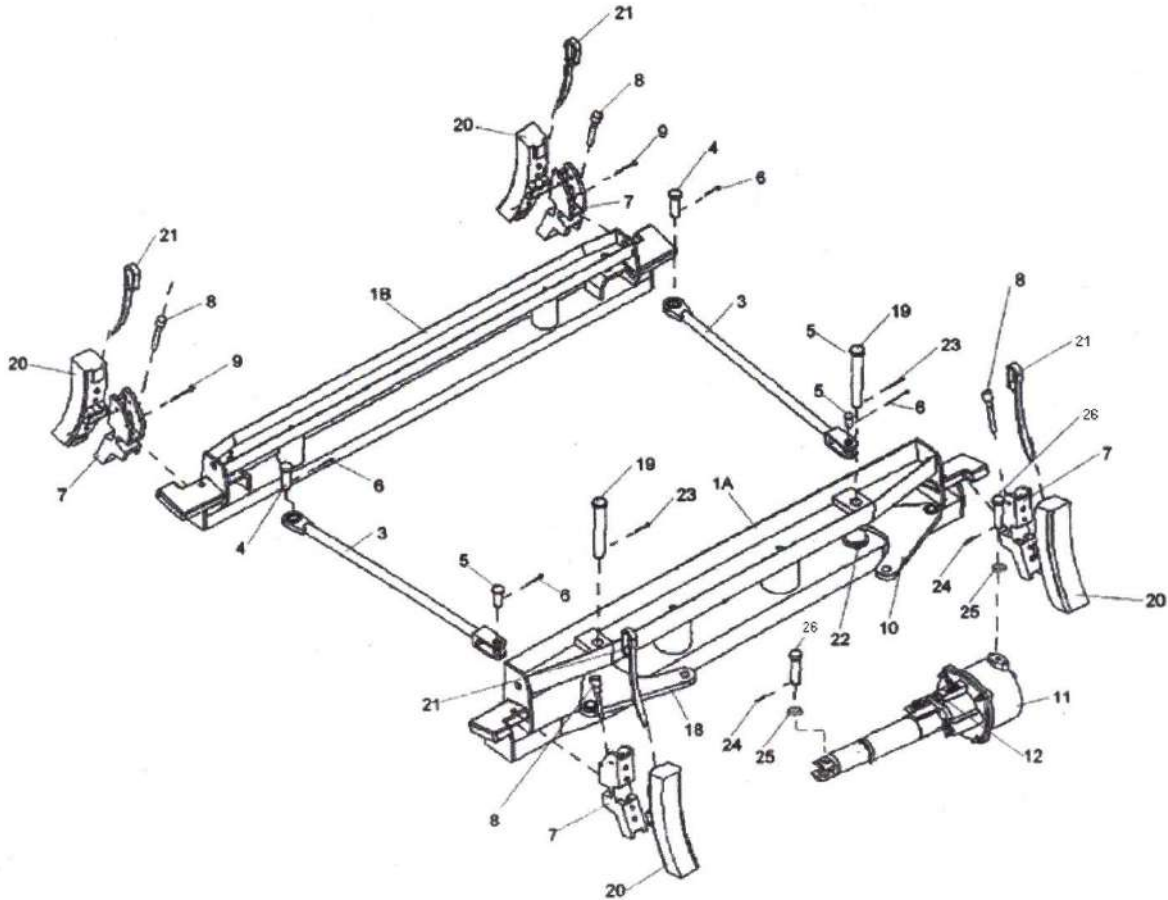
Adjustment is completely automatic and is accomplished by the inbuilt slack adjuster. The slack adjuster in the brake cylinder is double acting. It automatically maintains a constant piston stroke by taking up or letting out slack with each brake application. The piston stroke indicator is mounted on top of the non-pressure body of the brake cylinder. The extension of the brake cylinder ram will increase as the shoes and wheels wear. On a wagon in service, it will be clearly visible as a shiny ring near the ram scraper on the cylinder.

**Components of Bogie with Hand Brake Arrangement (See Figure – 7.41)**

<b>1.</b>	<b>Set of Brake Beams</b>
1(A)	Beam, Primary
1(B)	Beam, Secondary
3)	Push Rod Assy.
4)	Secondary Beam Pin
5)	Push Rod Pin
6)	Pin, Cotter (6.3mm dia x 50mm)

7)	Brake Head
8)	Pin, Brake Head
9)	Pin, Cotter (6.3mm dia x 75mm)
10)	Lever Assy. (RH)
11)	Cylinder Assy. 10" with Hand Brake

<b>Cylinder Assy. 10" with Hand Brake</b>	
12)	Piston Stroke Indicator
13)	Cable Assy.
14)	Pin, Cable
15)	Pin, Cotter
16)	Cable Bracket
17)	Cable Equalizer
18)	Lever Assy. (LH)
19)	Primary Beam Pin
20)	Brake Block
21)	Brake Block Key
22)	Washer, Thrust
23)	Pin, Cotter (8mm dia x 50mm)
24)	Dowel Sleeve
25)	Bush
26)	Brake Cylinder Pin



**FIGURE: 7.57**

**Components of Bogie without Hand Brake Arrangement (See Figure – 7.41)**

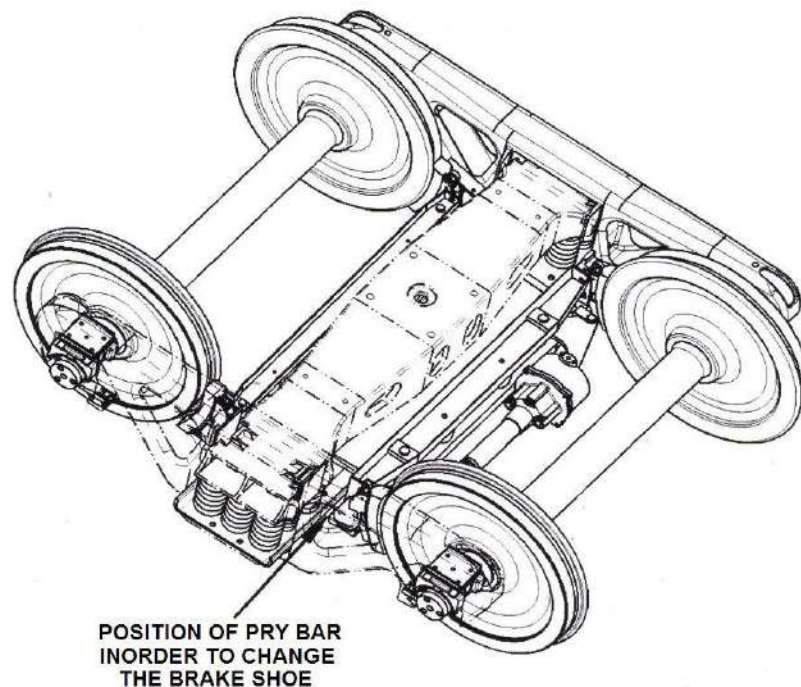
1)	Set of Brake Beams
1A)	Beam, Primary
1B)	Beam, Secondary
3)	Push Rod Assy.
4)	Secondary Beam Pin
5)	Push Rod Pin
6)	Pin, Cotter (6.3 dia x 50mm)
7)	Brake Head
8)	Pin, Brake Head
9)	Pin, Cotter (6.3 dia x 75)
10)	Lever Assy. (RH)



<b>Cylinder Assy. 10" without Hand Brake</b>	
11)	Cylinder Assy. 10" without Hand Brake
12)	Piston Stroke Indicator
18)	Lever Assy. (LH)
19)	Primary Beam Pin
20)	Brake Block
21)	Brake Block Key
22)	Washer, Thrust
23)	Pin, Cotter (8 mm dia x 50)
24)	Dowel Sleeve
25)	Bush
26)	Brake Cylinder Pin

### Procedure for changing of Brake Blocks (Refer figure 7.41)

- a. Changing the brake shoe with BMBS is easy and fast. Ensure that the brakes are released. Slip in a pry bar between the brake block & wheel on anyone wheel of the bogie. Force back the brake block from the wheel, thus retracting the double acting slack adjuster and creating space for inserting new brake blocks between the brake head and wheel. To get more gap push the beam across the side pockets
- b. Remove the brake block keys and replace the brake blocks. Secure the new brake blocks with the brake block keys. The slack adjuster will automatically adjust the brake shoe clearance to the proper value when the brakes are' applied and released. This usually takes from two to three brake applications.



**FIGURE: 7.58**

## H PROCEDURE FOR CHANGING OF PARTS AND LIFTING OF UNDERFRAME

### Isolation of Brake Cylinder

- a. There are two isolating cocks with vent in BC line for isolating each brake cylinder in the wagon.
- b. To isolate any particular Bogie / Brake Cylinder, move the isolating cock (OLP types) handle to closed position. This will stop the further feeding of corresponding brake cylinder and the air already present in the brake cylinder will get exhausted to atmosphere, thus, releasing the brakes in that particular bogie.

### Changing of Brake Head (7) (See figure 7.40 & 7.41)

- a. Ensure that the brakes are released. Slip in a pry bar between the brake block 20 & wheel on anyone wheel of the bogie. Force back the brake block from the wheel, thus retracting the double acting slack adjuster (figure-6) and creating the space between the brake block and the wheel.
- b. Remove the brake block key 21 and then the brake block 20.
- c. After obtaining enough clearance between the wheel & the brake heads 7, remove the cotter pin 9 & the brake head pin 8 consecutively to remove the desired brake head.
- d. Install a new brake head 7 and secure it with brake head pin 8 then a cotter pin 9. Bend cotter pin legs outwards.
- e. Place the brake block on the new brake head and secure the brake block with the brake block key.
- f. The slack adjuster will automatically adjust the brake shoe clearance to the proper value when the brakes are applied and released. This usually takes from one to three brake applications.

### Changing of Brake Cylinder (11) (See figure 7.40 & 7.41)

- a. Ensure, the brakes are released and the brake cylinder is completely vented. Retract the brake cylinder 11, use pry bar between wheels & brake blocks on both, the secondary beam 1 B & the primary beam 1 A. Force the brake cylinder 11 to retract completely.
- b. Disconnect the air hose from the cylinder assembly (11) flange.
- c. Remove the dowel pin 24, bush 25 then rod eye pin 4 on both sides of the cylinder. Install a new brake cylinder assembly 11, being sure the cylinder is of the same size and aligned in the same way as the previous cylinder, using rod eye pin 4. Secure the brake cylinder with bush 25 & dowel pin 24.
- d. Reconnect the air hose to the cylinder assembly 11 flange.
- e. Apply partial brakes 2 - 3 times in order to restore the internal slack adjuster's position.

### Note

For cylinders equipped with the hand brake cables (see fig. 15), it is necessary to:

- f. Disconnect the cable clevises from the equalizer 17 by removing the two cotter pins 15 and cable pins 14.

- g. Remove the two cables 13 from the cable bracket 16.

### **Changing of Lever Assembly {RH (10) & LH (18)}**

**(See figure 7.40 & 7.41)**

This change will be required if this part has been damaged or worn out.

- a. Remove the cotter pin 6 and the rod clevis pin 5 with pull rod. Remove the bush 25, dowel sleeve 24 and the rod eye pin 4 with brake cylinder. Remove the cotter pin 23 and pin lever 19 with the primary brake beam 1A. Pull the bell crank lever RH 10 & LH 18 from the beam assembly 1 A. Install a new lever RH 10 or LH 18 as applicable using the pin lever 19 and the cotter pin 23. Install pins 5 and cotter pin 6. Install pin 4 with bush 25 & dowel sleeve 24. Bend cotter pin legs.
- b. The slack adjuster will automatically adjust the brake shoe clearance to the proper value when the brakes are applied and released. This usually takes from one to three brake applications.

### **Changing of Push Rod (3) (See figure 7.40 & 7.41)**

This change will be required if this part has been damaged or worn out.

- a. Remove the cotter pin (6) and the rod clevis pin (5) with bell crank lever. Remove the cotter pin (6) and the pin rod eye (4) with secondary brake beam 1 B. Remove the pull rod from lever assembly RH 10 or LH 18. Pull the rod from the secondary beam. To install a new push rod, align the rod end hole with the mounting holes in the secondary beam 1 B and then insert the pin 4 and the cotter pin 6. Bend the cotter pin legs. Do the same procedure on the other end of the rod by aligning the rod with the lever assembly RH 10 or LH 18 with pin 5 and cotter pin 6.
- b. The slack adjuster will automatically adjust the brake shoe clearance to the proper value when the brakes are applied and released. This usually takes from one to three brake applications.

### **Lifting of under frame from Bogie**

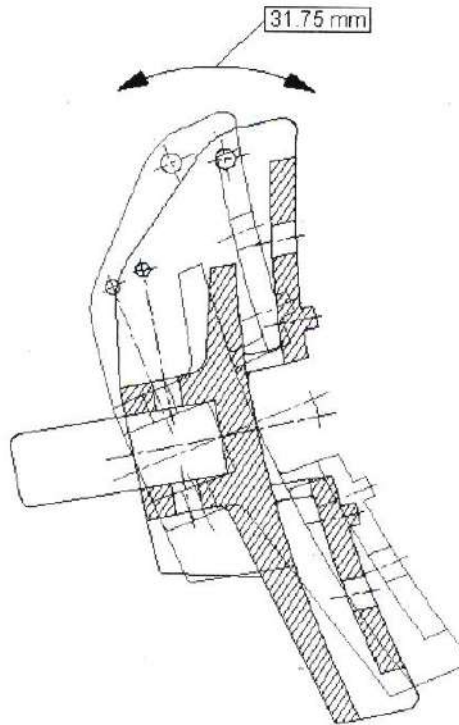
1. Disconnect the air hose from the flange of brake cylinder without hand brake cables by unscrewing the bolts.
2. Disconnect the air hose from the flange of brake cylinder with hand brake cables by unscrewing the bolts.
3. Disconnect both the cables from the equalizer cable by removing the split pins and the pins.
4. Detach the cables from the cable bracket by loosening the nuts on either side of the cable bracket. Remove the cables from the bracket after the nuts have been loosened and enough space is created for easy removal.

After the removal of brake cylinder hoses and the hand brake cables from the under frame, the wagon under frame can be lifted from the bogies.

The bogie can be dismantled or assembled with the bogie mounted parts by following maintenance instruction described earlier.

## I. CONDEMNING LIMITS OF SYSTEM COMPONENTS

### Brake Head (7) (See figure 7.42 & 7.43 )



**FIGURE -7.59 - Brake Head**

Brake Head 7 should be replaced if the following exists.

Check brake head tip. Push brake head forward and measure travel by pulling brake head all the way back. Tip travel should NOT exceed 31.75 mm.

### Bell Crank Lever Assembly RH (10) & LH (18) (See figure 7.42)

Bell Crank Levers should be replaced if anyone of the following exists:

#### 1. Excessive Wear on any surface

- ❖ Excessive is anything > 1.6 mm

#### 2. Worn, Damaged or Broken Spherical Bearing

- ❖ Worn/Enlarged Pin Holes
  - 25.4 mm Hole exceeds 26.7 mm in any direction (i.e.: oval condition)
  - 32 mm Hole exceeds 33 mm in any direction (i.e.: oval condition)

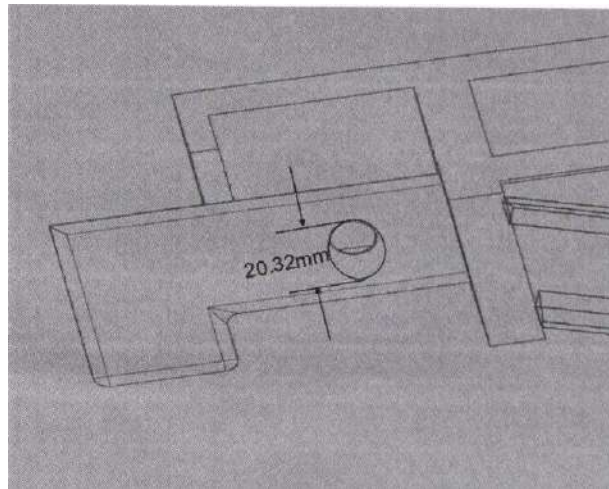
### Push Rod (3) (See figure 7.42)

Push Rods should be replaced if anyone of the following exists:

- ❖ Any part of the push rod is Bent

- ❖ Cracked or Damaged Welds
- ❖ Excessive Wear on any surface
  - Excessive is anything > 1.6 mm
- ❖ Worn, Damaged or Broken Spherical Bearing
- ❖ Worn/Enlarged Pin Hole
  - 25.4 mm Hole exceeds 26.7 mm in any direction (ie.: oval condition)
- ❖ .Clevis End Gap Exceeds 27.9 mm.

**Brake Beams 1 A & 1 B (See figure 7.59 & 7.60)**

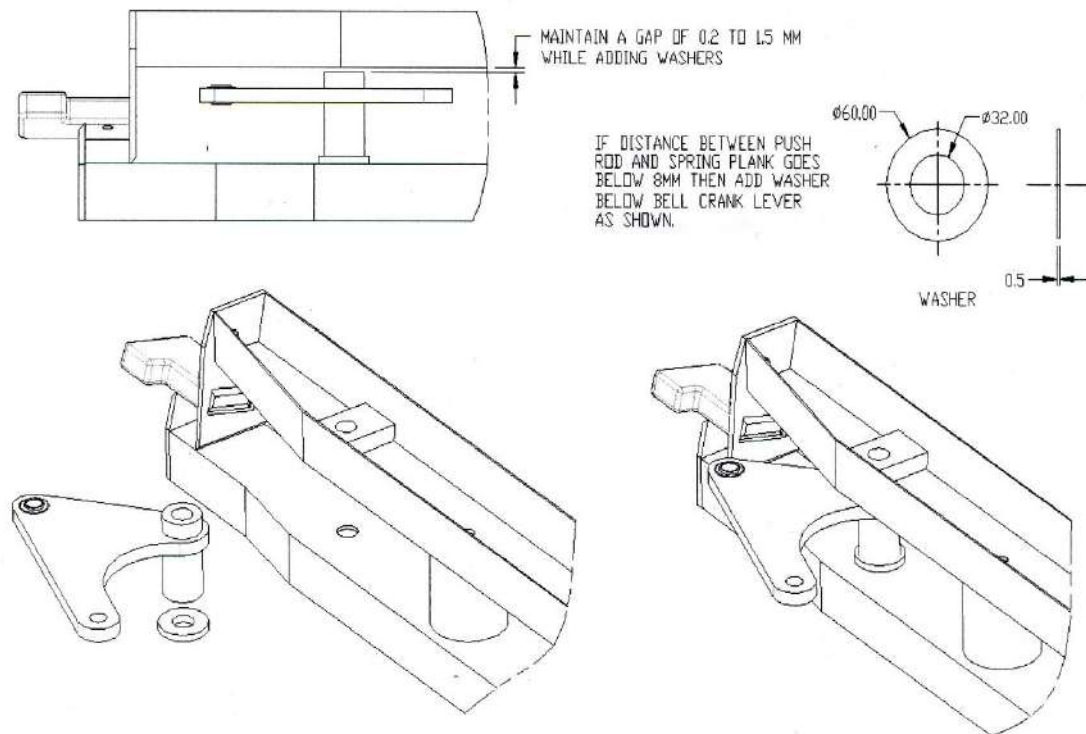


**FIGURE -7.60– Worn Condition**

***Brake Beam should be replaced if the following exists.***

Remove Brake Head and inspect Brake Head pin hole in Beam. If hole exceeds 20.32 mm in length, replace Beam. If not, replace brake head and recheck tip as described earlier. Tip should not exceed 31.75 mm (from FIRST check above). If tip does exceed 31.75 mm, replace Beam and Brake Head

**Gap between Bell crank lever RH 10 & LH 18 and the upper channel of Primary brake beam 1A (See figure 7.61 below)**

**FIGURE -7.61 – Worn Condition**

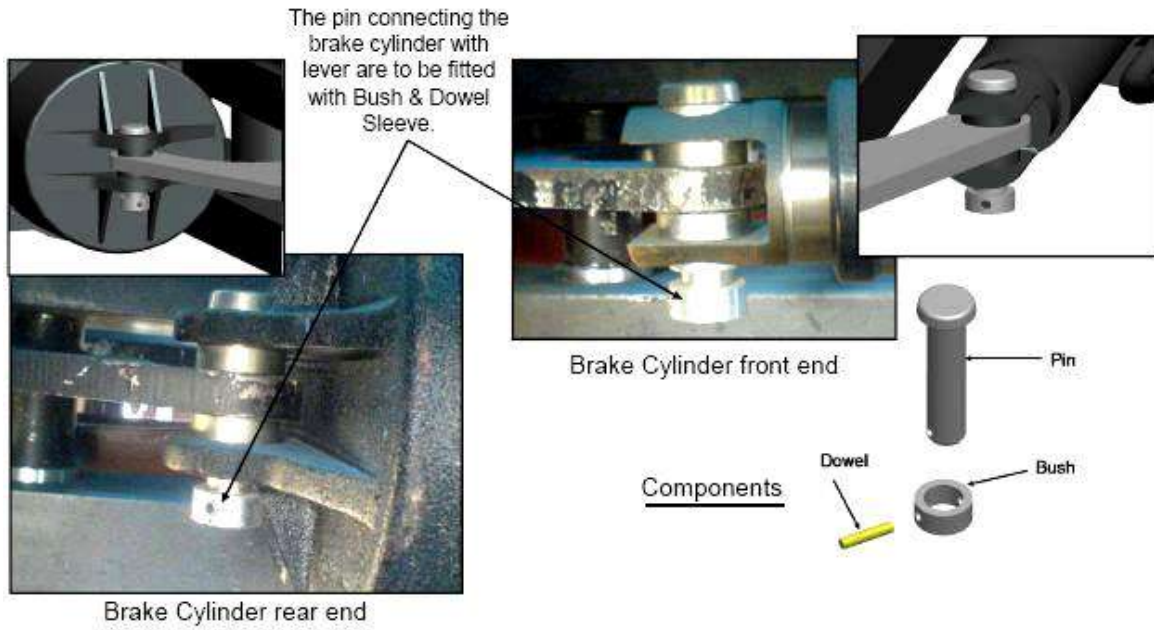
Measure the bell crank lever dimension with reference to the lever being supported inside the primary brake beam. Measure the maximum pass through gap.

Note the locations of the measurement for the lever and the position of the lever in regards to the primary brake beam.

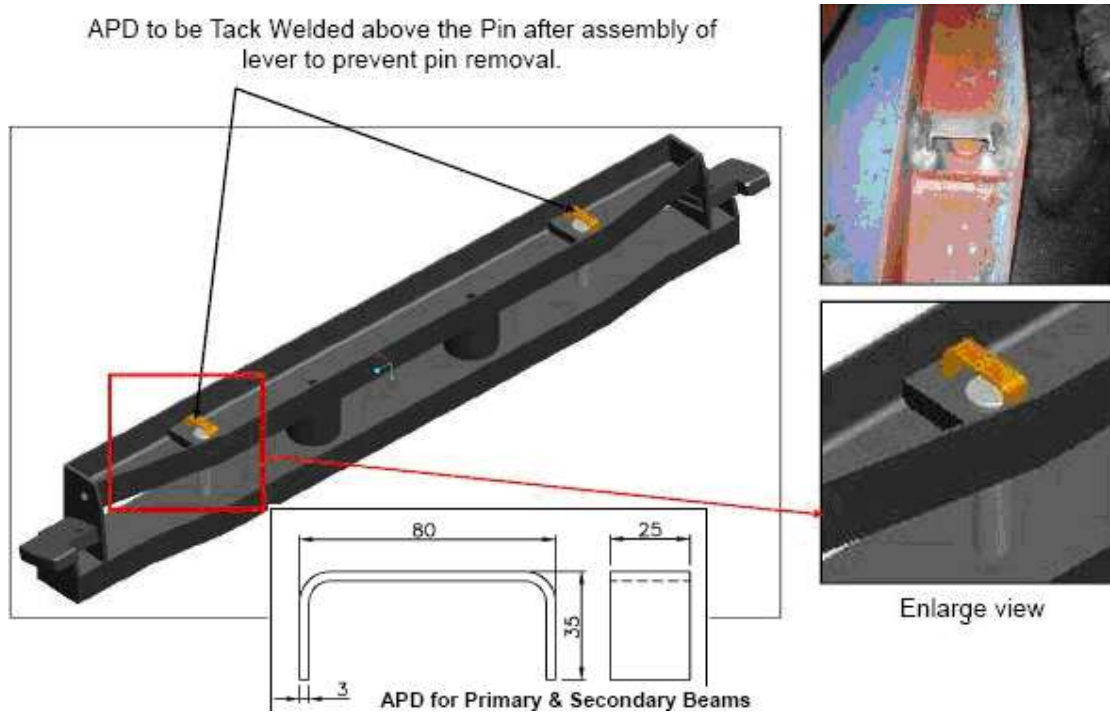
Use washers as demonstrated to adjust the gap.

**J. Anti Pilferage Devices (APDs)**

**(A) APD for Pins on Bogie Brake Cylinder**

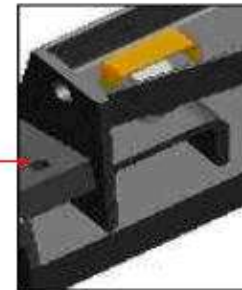
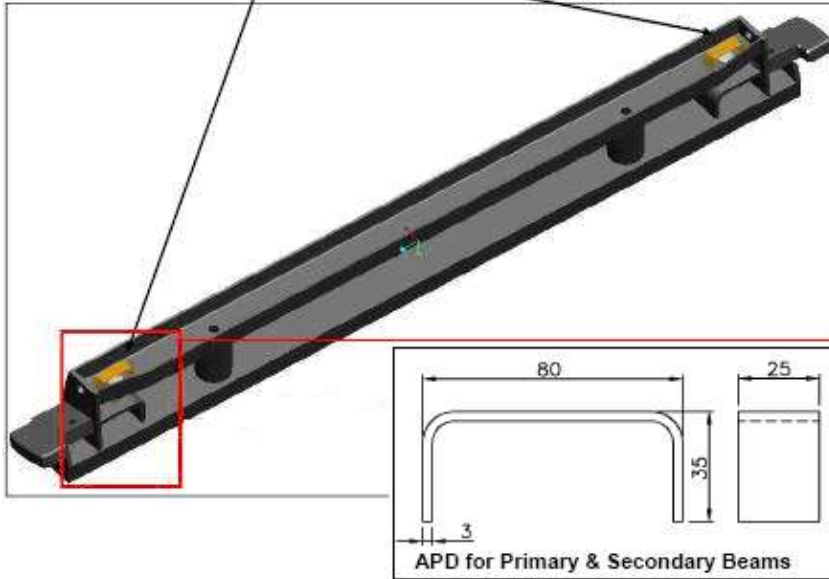


**(B) APD for Primary Brake Beam**



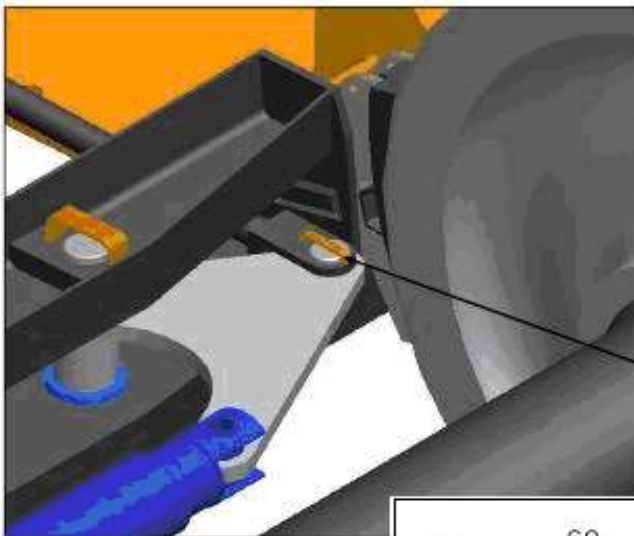
**C) APD for Secondary Brake Beam**

APD to be Tack Welded above the Pin after assembly of push rod to prevent pin removal.

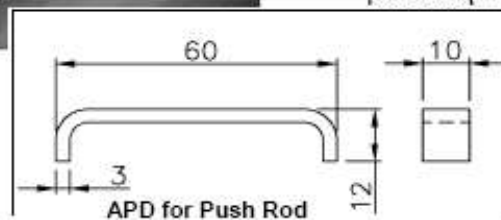


Enlarge View

**(D) APD for Push Rod**

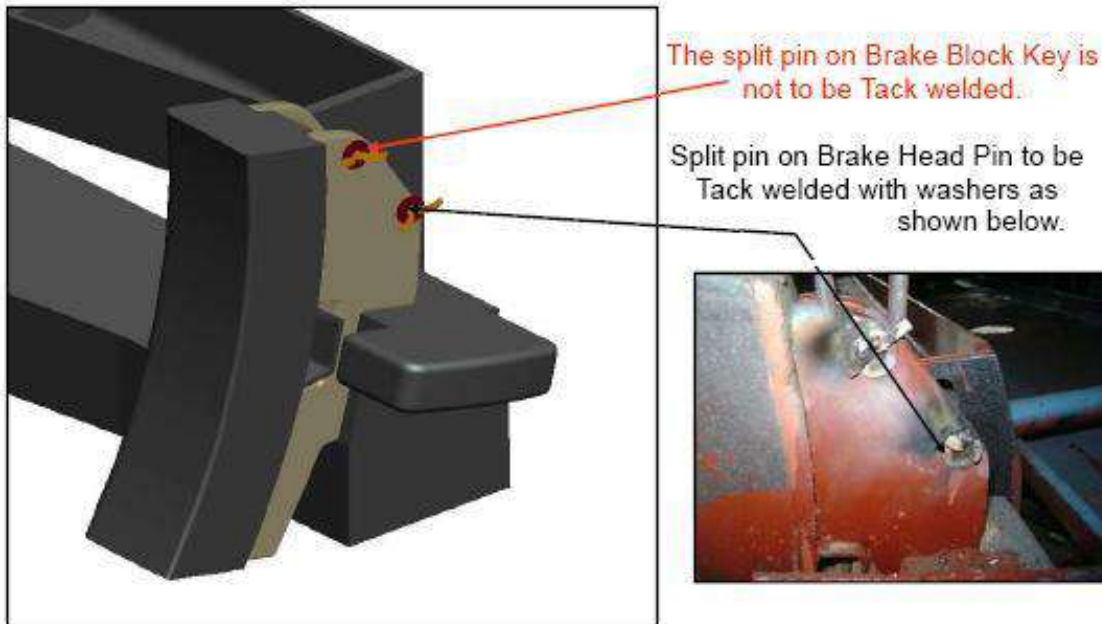


APD to be Tack Welded above the Pin after assembly as shown, to prevent pin removal.

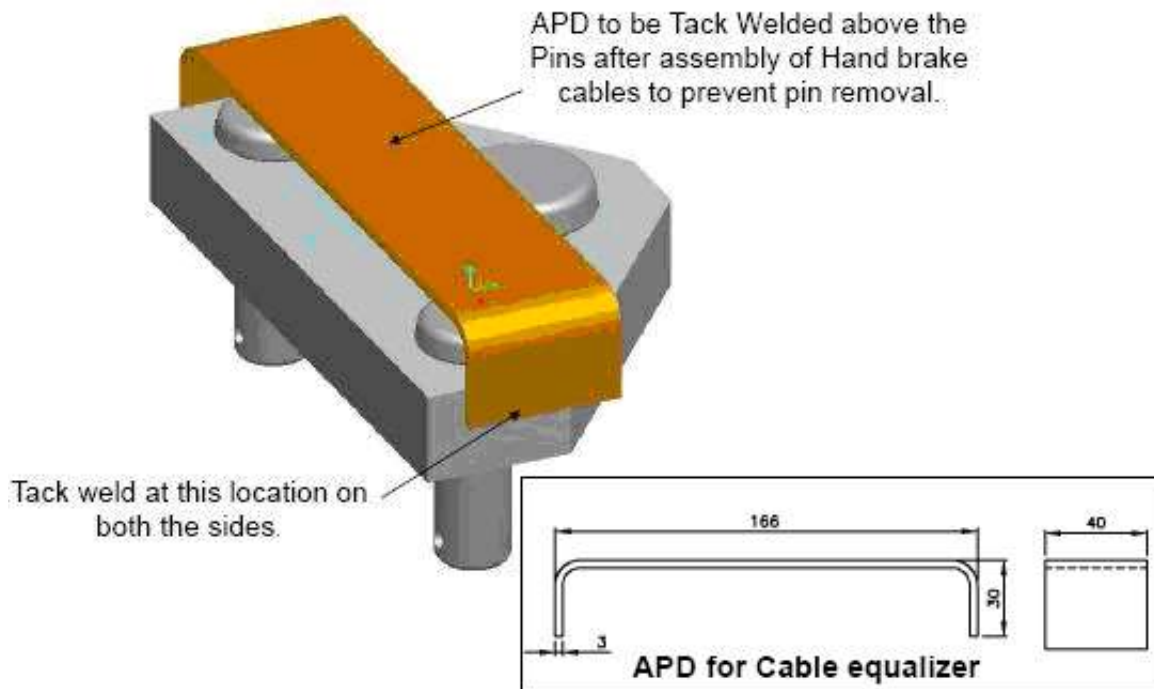




**(E) APD for Brake Head**

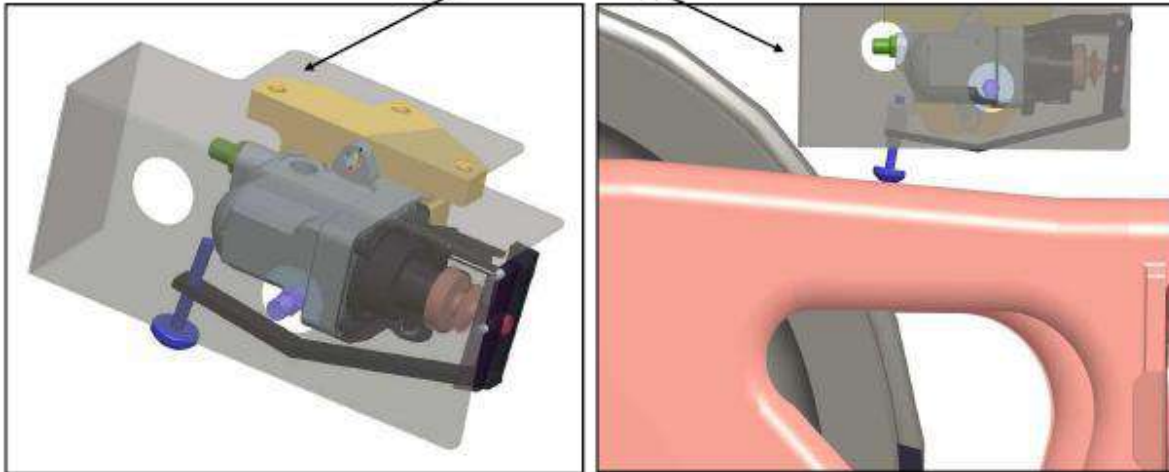


**(F) APD for Cable Equalizer**

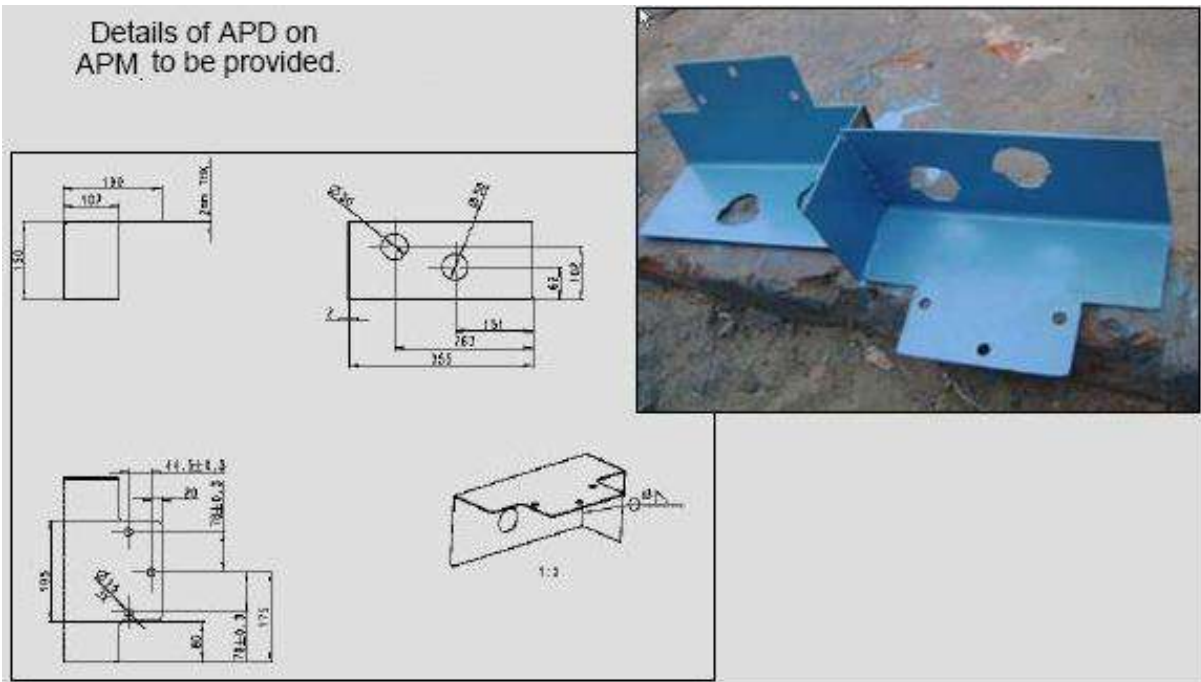


**(G)APD on APM**

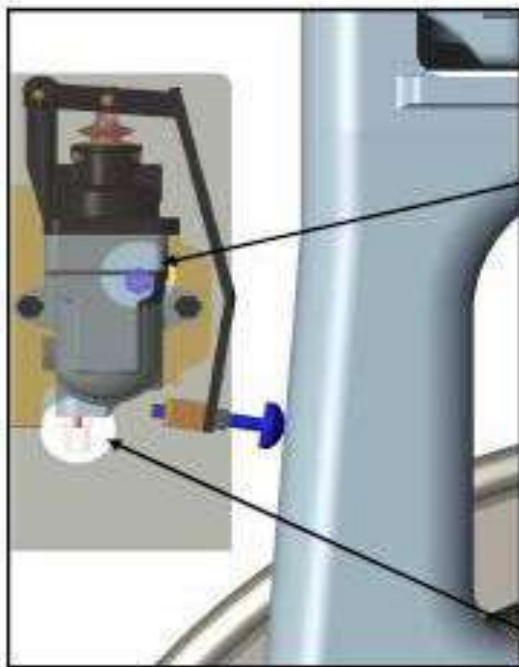
APD on APM to be provided as shown.



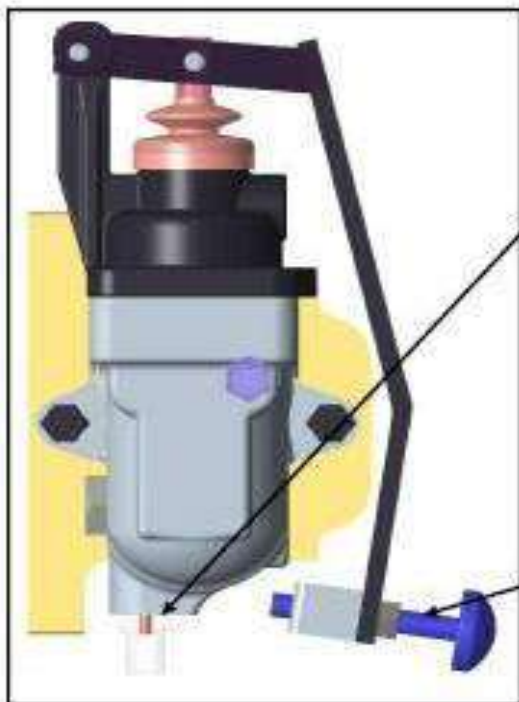
Details of APD on APM to be provided.



**(H) Lock nut on APM**



Port to connect the gauge to check BC pressure.



When the indicator (Orange) is out, it shows empty position. When the is inside, it shows loaded position.

Sensor Arm fitted with Adjustable Screw for adjustment on wagon.

**K. MAINTENANCE IN OPEN LINE****1. BOGIE RIGGING; BRAKE BEAMS, BELL CRANKS LEVERS & PUSH RODS**

- a) Check all the pin joints for any missing parts (pins, split pins, spring dowel, etc), if missing, provide the same.
- b) Check the components for missing or any physical damage, if found replace them.
- c) Check that the APD is provided on all the pins and on the APM.
- d) Check that the all hoses are properly tightened and are not threatened to be damaged by axle or wheel. If so properly clamped them.

**2. BRAKE CYLINDER**

- a) Check for any physical damage of components or leakage.
- b) Check that the piston indicator is fully in released condition.
- c) In case of brake cylinder with hand brake cables, the cables are not entangled or resting / touching the axle, check that movement cable is free.

**3. APM DEVICE**

- a) Check for any physical damage to the valve.
- b) Check that the indicator in during the release.
- c) Clean the Indicator.
- d) Check the tightness of the lock nuts on sensor arm lever, if found loose, tighten them and also verify the Gap as specified.
- e) Check that the valve's sensing arm is moving freely.

**4. HAND BRAKE RIGGING**

- a) Check all the pin joints for any missing parts (pins, split pins, spring dowel, etc), if missing, provide the same.
- b) Check the components for missing or any physical damage, if found replace them.

**Spares to be maintained in open lines /ROH Depots**

Following items to be maintained in the open lines /ROH depot for replacement against missing or damaged parts.

**Bogie Equipment**

S. No.	Component Description	Qty/ Wagon
1	Cylinder Assembly without Handbrake	1
2	Cylinder Assembly with Handbrake	1
3	APM valve Assembly	1
4	Reservoir for APM	1
5	Primary Beam	2
6	Secondary Beam	2
7	Lever Assembly ( Right Hand)	2
8	Lever Assembly (Left Hand)	2
9	Push Rod Assembly	4

10	Brake Head	8
----	------------	---

### Pins, Split Pins (Bogie Equipment)

S. No.	Component Description	Qty/ Wagon
1	Pin; Clevis	4
2	Pin; Clevis	4
3	Pin; Clevis	4
4	Pin; Clevis	4
5	Pin; Brake Head	8
6	Pin	16
7	Pin	4
8	Pin	8
9	Washer	4

### Hoses & Hardware (Bogie Equipment)

S. No.	Component Description	Qty/ Wagon
1	Hose Assy. 1/2" With Flange	1
2	Hose Assy. 1" With Flange	2
3	O-Ring	2
4	O-Ring	2
5	Spring Washer	4
6	Screw, Hex Head; Zinc Plated	8
7	Washer, Lock; Cad Plated	8
8	Locknut; Zinc Plated	1
9	Screw, Hex Head; Zinc Plated	4

## L. ROH SCHEDULE FOR WAGONS FITTED WITH BMBS AIR BRAKE SYSTEM

In routine overhaul, first test the brake system of BMBS using single wagon test rig. Following action should be taken for the defects / discrepancies identified during testing.

### Brake Cylinders

Check & replace brake cylinder by tested brake cylinder if following defects are identified:

- Check the brake cylinder for any physical damage or leakage.
- In case of brake cylinder with hand brake cables, check that the movement of cables is free
- Ensure that the piston indicator is in fully released condition.

**BRAKE BEAMS**

- (a) Check for any physical damage, crack, etc, if found replace them. Check for rusting & corrosion and if found repaint them.
- (b) Replace all the PINS, washer, split pins, dowel pins from OEMs.
- (c) Check the GAP at pivot pin on the primary brake beam as shown in the condemning limit of the system components.
- (d) Check brake head for loosening or damage as shown in the condemning limit of the system components.

**LEVERS & PUSH RODS**

- (a) Replace the Bell crank lever, if any of the parameters specified in the condemning limits is observed.
- (b) Replace the push rod, if any of the parameters specified in the condemning limits is observed.

**APM VALVE**

- (a) Clean the Indicator.
- (b) Check the APM valve;
  - ❖ Any physical damage
  - ❖ Valve's sensing arm is moving freely and is fully in.
  - ❖ Check the leakage.
  - ❖ Tightness of the lock nuts on sensor arm lever, if found loose, tighten them.
- (c) Check the Gap between the sensor arm and the side frame, if required re-adjust.

**HAND BRAKE RIGGING**

- (a) Check the pin joints / components for missing or any physical damage, if found replace them.
- (b) Replace all the PINS, washer, split pins, dowel pins, plastic bushes.

**HOSES & PIPE JOINTS**

- (a) Check the hoses for any cracks / damage. If so, replace them.
- (b) Check that the hoses are properly tightened and are not threatened to be damaged by axle or wheel. If so properly clamped them.
- (c) Check the pipe joints for leakages, if so, tighten them properly.

**M. Critical check points for wagons fitted with BMBS****SWTR Testing**

1. SWTR test for wagon to be done as per para 720F

**Bogie & Brake cylinder**

1. Push rod & spring plank clearance (min 10mm).
2. The split pin over the Brake head pin is tack welded with washer.
3. The brake cylinder pins are locked with bush and dowel sleeve.
4. Split pins are provided on all pins, bent properly & provided with APDs.

**APM Device**

1. The APM valve is mounted properly and its sensor arm is touching in middle of side frame.
2. The gap between the sensing point and side frame bottom is adjusted as specified for the wagon and is provided with additional check nut and APD.
3. Check that the APM hose is properly tightened & secured through clamp on under-frame.

**Under frame & Piping**

1. The BC isolating cocks in the BC line have their vent side towards the Brake cylinder (Both sides) and their handles are parallel to pipe line.
2. The brake hoses for Brake cylinder are properly secured and not resting on axle or rubbing with any other under frame members.
3. The brackets for hand brake arrangement are properly secured, the movement of the hand brake system is smooth and unrestricted.

**N. POH SCHEDULE FOR WAGONS FITTED WITH BMBS AIR BRAKE SYSTEM****BOGIE RIGGING**

Replace all the must change items as listed in the list below on the Bogie.

**BRAKE BEAMS**

- a) Check the beams for rusting & corrosion and if found repair & repaint them.
- b) Check the GAP at pivot pin on the primary brake beam as shown in the condemning limit *of* the system components.
- c) Check brake head for loosening or damage as shown in the condemning limits *of* the system components.

**BELL CRANKS LEVERS & PUSH RODS**

- a) Replace the Bell Crank levers, if the critical parameters found to in condemning limits as specified.
- b) Replace the Push Rod, if the critical parameters found to in condemning limits as specified.

**HAND BRAKE RIGGING**

- a) Check for any physical damage components, if found replace them.
- b) Brake rigging brackets, bolts and nuts should be examined for rusting, looseness, damaged threads, etc and replaced.
- c) Replace all the pins, washer, split pins, dowel pins from OEMs.
- d) The plastic bushes should be changed.

**BRAKE CYLINDER**

- a) Overhaul the brake cylinder as per procedure explained in the manual.
- b) Replace the must change items.
- c) Check the condition base items, if found worn or damaged, replace them.
- d) Test the brake cylinder as per the procedure given in the manual.

**APM DEVICE**

- a) Overhaul the APM Device as per procedure explained in the manual.
- b) Replace the must change items as enlisted in the manual.
- c) Check the condition base items, if found worn or damaged, replace them.
- d) Test the APM Device as per the procedure given in the manual.
- e) Check the Gap between the sensor point and the side frame surface and readjust the same as specified for the wagon type.

**HOSES, PIPES & PIPE JOINTS**

- a) Check the hoses for any cracks / damage. If so, replace them.
- b) Clean the pipes as per the procedure laid down by ROSO specification No. 04-ABR.

***[Must change items during POH for Bogie Mounted brake system Bogie Equipment***

SNo.	Component Description	Qty/Wagon
1	Pin; Clevis	4
2	Pin; Clevis	4
3	Pin; Clevis	4
4	Pin; Clevis	4
5	Pin; Brake Head	8
6	Pin;	16
8	Pin;	4
9	Pin;	8
10	Washer;	4



**Hand Brake Equipment**

1	Pin, Cable	2
2	Pin, Tie Rod	1
3	Pin Cotter, Cable pin	2
4	Split Pin (BMBS)	1

**Items to be replaced on conditional basis**

SNo.	Component Description	Qty/ Wagon
1	Hose Assy. 1/2" With Flange	1
2	Brake Head;	8
3	Hose Assy. L" With Flange	2
4	Spring Washer	4
5	a-Ring	2
6	a-Ring	2
7	Screw, Hex Head; Zinc Plated	8
8	Washer, Lock; Cad Plated	8
9	Screw, Hex Head; Zinc Plated	4

**O. Do's & Don'ts for Bogie Mounted brake System****Do's****Bogie Rigging**

- ❖ Do ensure that the side frame pockets are of correct dimension and free of all restriction.
- ❖ Do ensure that the fitment dimensions in Bogie, critical for fitment of BMBS are maintained within their specified limits.
- ❖ Do ensure that all the side frame pocket liners are properly cleaned & are within the specified limits.
- ❖ Do ensure there is free sliding of Brake Beams inside the side frame pocket liners.
- ❖ Do ensure that there is proper push rod & spring' plank clearance. If push rod clearance is less, then check the necessary bogie dimensions.
- ❖ Do ensure that there is proper fitment of brake block key with Brake block and brake head.
- ❖ Do ensure that there is sufficient gap (after the system is retracted) to change the brake blocks.
- ❖ Do ensure to use bush and dowel pin to lock the brake cylinder pins.
- ❖ Do ensure that all split pin are in place and are bent properly with their arms 90° apart.
- ❖ Do ensure that APDs are provided on all the pins of the bogie rigging.

**Brake Cylinder**

- ❖ Do ensure to blow the steel pipes connecting the brake cylinder before fitment to prevent the dirt particles going into the brake cylinder. This can be done by making 2-3 brake applications before connection of Hose pipe with Brake Cylinder.
- ❖ Do ensure that the cables are not pulled out of the brake cylinder on making hand brake connections.
- ❖ Do ensure that there is no rubbing of two hand brake cable together or resting on the axle.

**APM Device**

- ❖ Do ensure correct gap between the sensing point of APM valve & surface of side frame. If not, then adjust the same.
- ❖ Do ensure to put the additional check nut on the adjusting screw to lock the same in position.
- ❖ Do ensure that changeover takes place after putting block between the sensor point and side frame as indicated at clause no. 721F table-1
- ❖ Do ensure that empty / load indicator of the APM valve (Orange coloured) is visible during empty condition.
- ❖ Do ensure that the reservoir for APM valve is secured properly with the underframe.

**Piping layout and fitment**

- ❖ Do ensure proper orientation of Check Valve & Bogie Isolating Cocks. The vent side of the isolating cock with vent should be on the brake cylinder side.
- ❖ Do ensure to use the correct size of bolts, screws, nuts and washers as specified. Use of wrong size bolts / screw could damage the threads on the brake cylinder / APM valve.
- ❖ Do ensure proper clamping of APM Valve hose with under frame.
- ❖ Do ensure that there is no rubbing of rubber hoses with axle, wheel or underframe members.

**Hand Brake Arrangement**

- ❖ Do ensure to weld the hand brake cable bracket at its correct location. It should be welded straight and cables should be properly tightened to the bracket.
- ❖ Do ensure to weld the horizontal lever bracket at its correct location.
- ❖ Do ensure that the horizontal lever is properly supported by support brackets and have unrestricted movement.
- ❖ Do ensure that there is proper hand brake arrangement movement. After applying the hand brake, there should not be any ringing sound after striking wheels.
- ❖ Do ensure that there is no obstacle during return of hand brake cable after releasing hand brake. Investigate the restriction for the cables and do the necessary rectification.
- ❖ Do ensure to properly lubricate the hand brake screw, nut and pivots to reduce the friction and ensure smooth movement.

**Don'ts**

- ❖ Do not fit BMBS system if the Bogie parameters are not within the specified limits.
- ❖ Does not tack weld the BMBS pins / split pins on the bogie.
- ❖ Do not hammer on beams and brake block.
- ❖ Do not hit the indicator on the brake cylinder.
- ❖ Do not carry bogies by cranes fitted with cylinder and without wheeling, by fastened by chain wrapped in centre. Use fork lifter or chain should hook in side frame holes only.
- ❖ Do not use L-type brake blocks with Bogie Mounted Brake system.
- ❖ Do not use the non-standard pin, bolts for the fitment of BMBS items.

**P. TESTING OF APM :**

After the completion of the above, the EI-60 Empty/ Load Valve must be tested in accordance with the test specifications.

**Test Preparation:**

*The following items are needed to assemble the Test Fixture.*

1. Load Sensing Device holding fixture
2. 2 nos. pressure gauge
3. 10 litre reservoir
4. 6.6 litre reservoir
5. 2 nos. - cut out cocks with vent.
6. Pressure Regulator
7. 25mm high block
8. Pipes and hoses

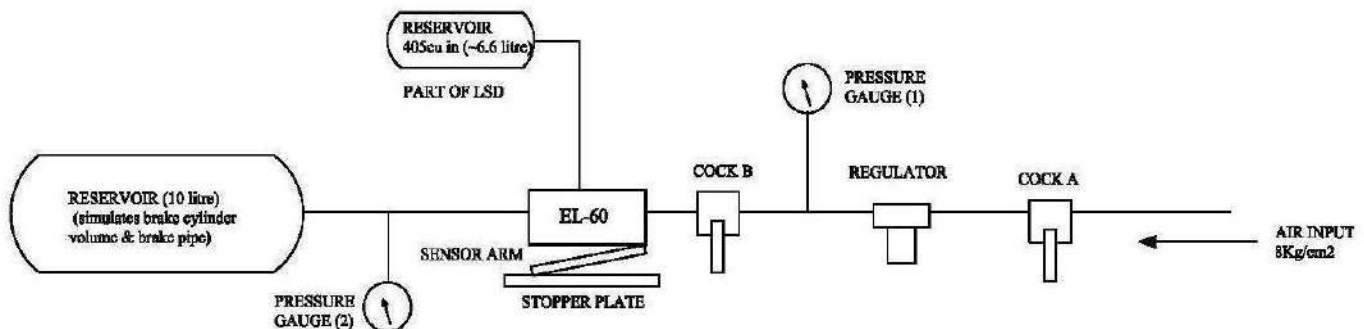
**WARNING:**

High pressure air is present in the test rack and assembly being tested. Pressure will vent from cocks and/or valve exhaust ports when test rack cocks are manipulated or when control devices are operated. To minimize the risk of personal injury from pressure exhausting, ensure that all persons stand clear of the exhaust path and that hearing protection and eye protection are worn at all times.

## Test Procedure for APM :

### A. LOAD POSITION & LEAKAGE TEST:

1. Place a 25mm high block between the adjusting screw and the stopper plate.
2. Open cock A and apply the main supply pressure. Pressure gauge no.1 should show 3.8 kg/cm<sup>2</sup> pressure otherwise adjust the regulator to get 3.8 kg/cm<sup>2</sup>.
3. Open cock B and apply 3.8 kg/cm<sup>2</sup> pressure to the load-sensing device.
4. As the sensor arm comes in contact with the block, note the reading at pressure gauge no.2. It should be 3.8 +/- 0.1kg/cm<sup>2</sup>.
5. Check the empty load indicator. It should remain retracted.
6. Check the leakage at all joints and ports. No leakage is allowed.
7. Close cock A and B and reduce pressure to 0 kg/cm<sup>2</sup>.
8. Remove the 25mm block from between the sensor arm adjusting screw and the stopper plate.



**Pneumatic Schematic Diagram for Testing of APM**

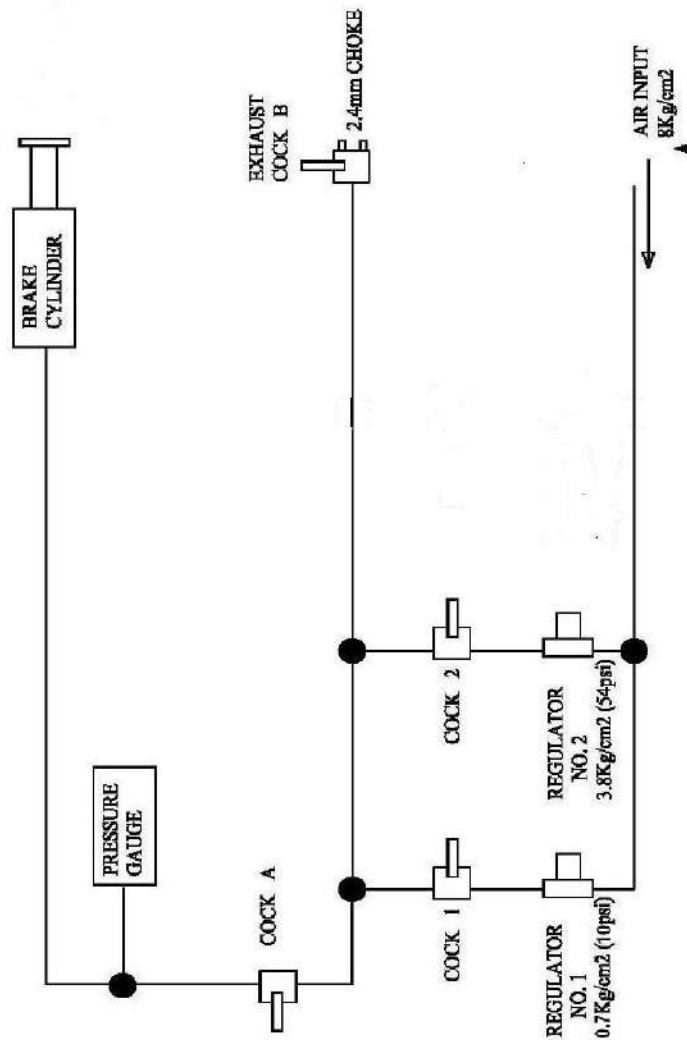
### B. EMPTY POSITION & LEAKAGE TEST:

1. Open cock A and apply the main supply pressure. Pressure gauge no.1 should show 3.8kg/cm<sup>2</sup> pressure otherwise adjust the regulator to get 3.8kg/cm<sup>2</sup>.
2. Open cock B and apply 3.8kg/cm<sup>2</sup> pressure to the load-sensing device.
3. As the sensor arm stops moving further down, note the reading at pressure gauge no.2. It should be 2.2 +/- 0.1kg/cm<sup>2</sup>.
4. Check the empty load indicator. It should be completely extended.
5. Check the leakage at all joints and ports. No leakage is allowed.
6. Close cock A and B and reduce pressure to 0kg/cm<sup>2</sup>



**TEST NO. 2 – HIGH PRESSURE LEAKAGE:**

1. Commence test with cock “A” open
2. Open cock 2 and apply a pressure of 3.8 kg/cm<sup>2</sup> to the brake cylinder.
3. Close cock “A”, then cock 2 and allow one minute temperature effect.
4. Note the reading at pressure gauge. Note the pressure drop for 10 minutes. No leakage is allowed.
5. Open Exhaust cock “B” and pressure reduces to 0 kg/cm<sup>2</sup>.



(SCHEMATIC DIAGRAM FOR BRAKE  
CYLINDER TEST BENCH)

*( MAINTENANCE MANUAL FOR WAGONS- 2015 )*

# CHAPTER – 8



# DRAW AND BUFFING GEAR





## **CHAPTER 8**

### **DRAW AND BUFFING GEAR**

#### **801. GENERAL**

There are two main arrangements of draft and buffing gear in use on Broad Gauge. The older arrangement, which is found on few wagons, consists of a screw coupling with side buffers. In this design the draft load is transmitted through the screw coupling, draw hook and draw hook springs while the buffing force is borne by the side buffers. The conventional screw coupling (WA/BD-125) has a working load of 22.5t. The restrictions of size and weight limit the extent to which the draft capacity of this coupling can be improved. Recognizing this fact, the other arrangement on BG wagons is that of a Centre Buffer Coupler (CBC) which transmits both draft and buffing loads. The knuckle type centre buffer coupler was adopted for BOX, BOXN and other new design of wagons. Later on, a smaller knuckle type coupler, known as the Alliance-II coupler, was introduced for four wheeler wagons. The working strength of CBC and Alliance-II coupler is 120 tonnes and 54 tonnes respectively. CBC also has a transition version called "Transition Coupler" which incorporates a screw coupling and a pair of side buffers to permit attachment with wagons fitted with screw coupling.

The conventional Draw and Buffing gear have been phased out hence details of these have not been included in this manual. Since now-a-days, high capacity Centre Buffer Coupler (CBC) and Draft Gear are used on BG freight stock, paras 802 to 810 have been deleted. For maintenance of draw and buffing gear 2002 version of this manual should be referred.

#### **802. CENTRE BUFFER COUPLER & DRAFT GEAR**

- A) Indian Railway uses AAR type centre buffer couplers having E-type head and F-type shank for freight stock on Broad Gauge system. These couplers are generally as per requirements of AAR specifications M-201, M-205 and M-211. The upgraded indigenous CBCs(UHTE) as per RDSO specs. No. WD-70-BD-10 are also being fitted in the wagons.
- B) The draft capacity of the AAR coupler depends on the strength of knuckle, which is weakest link in the assembly. The yield strength of knuckle of material AAR M-201 Grade 'C' & Grade 'E' is 132 t and 180 t respectively.
- C) **ADVANTAGES OF AAR CENTRE BUFFER COUPLER**
- Coupler and buffing gear are both located together at the centre of the wagon.
  - Centre buffer coupler is identical at either end of the wagon and hence wagon direction is immaterial.
  - Coupling action between wagons is automatic.
  - With transition arrangement, coupling with screw coupling is possible.

### 803. PARTS OF CENTRE BUFFER COUPLER ASSEMBLY

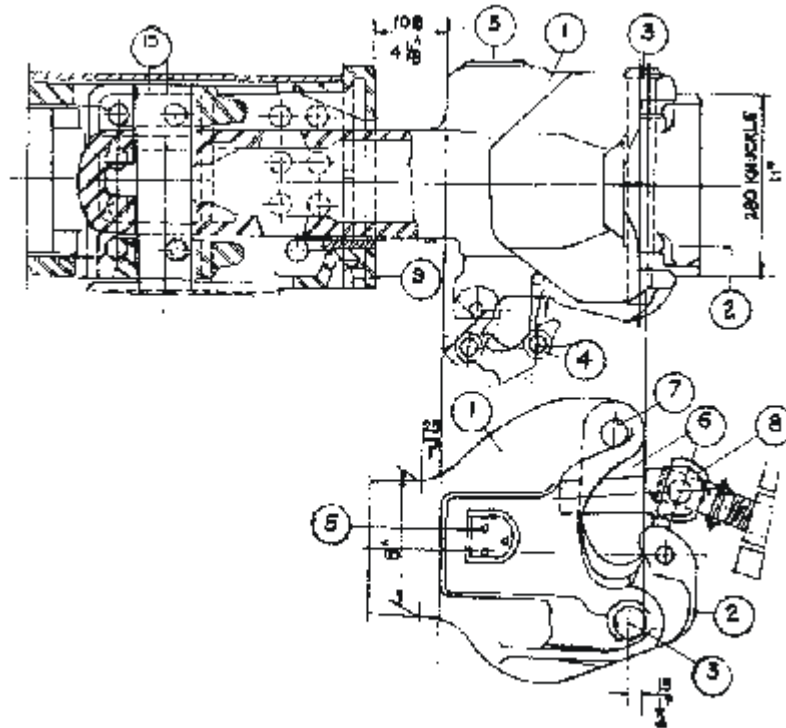
*The main parts of Centre Buffer Coupler are as under:-*

- i) Coupler body
- ii) Knuckle
- iii) Knuckle pivot pin with washer
- iv) Lock
- v) Knuckle thrower
- vi) Toggle
- vii) Universal lock lift lever connector
- viii) Lock lift lever hook
- ix) Lock lift rivet
- x) Lock lift lever rivet
- xi) Top lifter hole cap
- xii) Yoke pin
- xiii) Yoke
- xiv) Yoke pin support.
- xv) Striker casting
- xvi) Striker casting wear plate
- xvii) Shank wear plate
- xviii) Yoke support plate
- xix) Draft Gear arrangement with front follower
- xx) Safety bracket with anchor plate
- xxi) Uncoupling gear arrangement
- xxii) Back stop
- xxiii) Clevis for Transition type coupler only
- xxiv) Screw coupling for Transition type coupler only
- xxv) Clevis pin for transition type coupler only

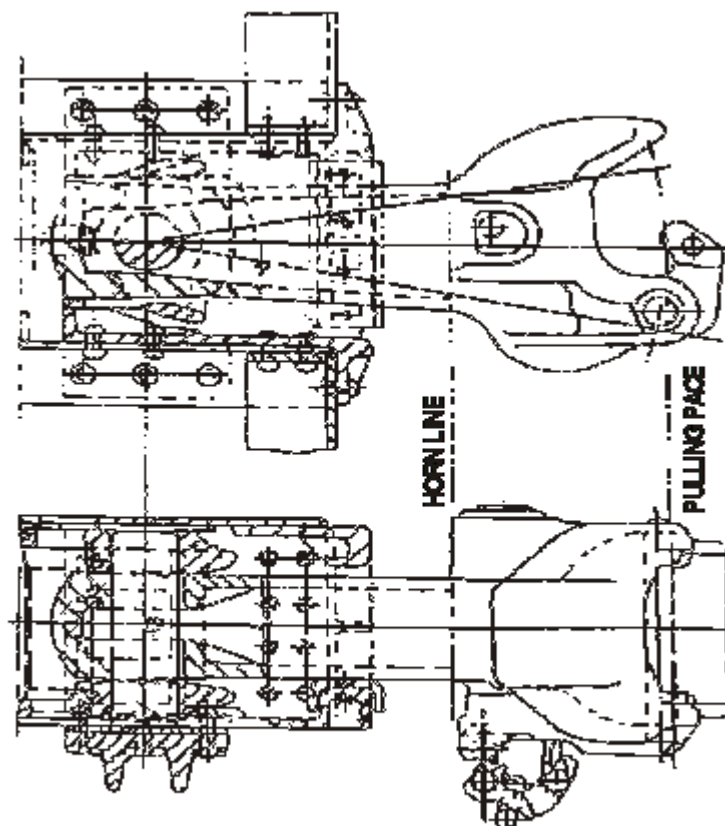
All parts of non-transition coupler are identical and therefore interchangeable with those of the transition type coupler except striker casting with wear plate and coupler body with shank. In transition CBC coupler body with shank is longer and is provided with an arrangement to fit clevis with the help of clevis pin.

### 804. INSPECTION OF CBC

- A) **Coupler and operating mechanism:** When inspection of coupler and coupler operating mechanism is made, it is important to check when the coupler operating mechanism is operated to fully open the knuckle, and the knuckle is slowly closed, the lock drops freely and the mechanism returns to fully locked position. The lock position is indicated by the toggle, which is clearly visible below the coupler head.
- B) Only dry lubricant shall be applied to the coupler head or the coupler head fittings. This lubricant may be applied using water, alcohol, or other non-petroleum based carrier.



**FIG 8.1 TRANSITION COUPLER**



**FIG 8.2: NON-TRANSITION CBC**

- C) Only exposed surfaces of Coupler and Yoke shall be painted with Black quick drying paint in accordance with IRS R6. Paint must be applied to the inside of the Coupler or internal fittings. Painting shall be done after the completion of inspection of Coupler & Yoke of acceptable casting lot.
- D) When in the transition Centre Buffer Coupler, the knuckle does not move freely, grind the top face of "top pulling lug" and "lock face" of knuckle in position. If still not free, remove knuckle and clean "pin protector guides" on coupler head. If, after attending to knuckle, the lock still does not fall, remove the lock and grind "locking face knuckle side" on lock so that the lock falls freely.
- E) Inspection of couplers, whilst fitted to wagons, should be made to ensure proper coupling any position which it can assume during train operation. The procedure is as follows:-
  - a. Check correct operation in order to ascertain that full knuckle throw, lock set, lock-to-lock (anti-creep) and locking is obtained. If any of these functions be unsatisfactory, they should be corrected by replacing the defective components.
  - b. Check that the shank is not bent out of alignment with the head. If defective, the coupler shall be removed for straightening of shank.
  - c. Examine shank wear plates (when fitted) and if worn through, the couplers shall be removed for fitting of new plates. Examine wear on shank (when wear plates not fitted) and if wear is approaching 6.5 mm (1/4"), the coupler shall be removed for building up of shank by welding.
  - d. Examine head for cracks in the knuckle side wall. If cracked, the coupler shall be removed.
  - e. Check the distance between the nose of the knuckle and the guard arm with gauge No. 1. If it passes (which is 5.5/16" long), it indicates that the coupler has its condemning limit. In such a case the knuckle pivot pin, lock etc. should be replaced so that gauge No.2 does not pass. If this gauge passes, then the coupler should be removed.
  - f. Examine the operating mechanism. If defective or deficient, the defective or deficient components should be replaced to ensure free movement.
  - g. Check knuckle pin & clevis pin to ensure that pin of correct size has been used. Check fastening arrangement of knuckle pin and clevis pin. The former has a welded washer while the later has a riveted head over a washer in position.
  - h. Coupler height should be checked in accordance with IRCA Part III Rule No. 2.13.7.
  - i. All defective/deficient components shall be replaced in CBC, clevis and screw coupling (in case of transition couplers).

### **805. INSPECTION OF DRAFT GEARS (MK-50 & RF-361)**

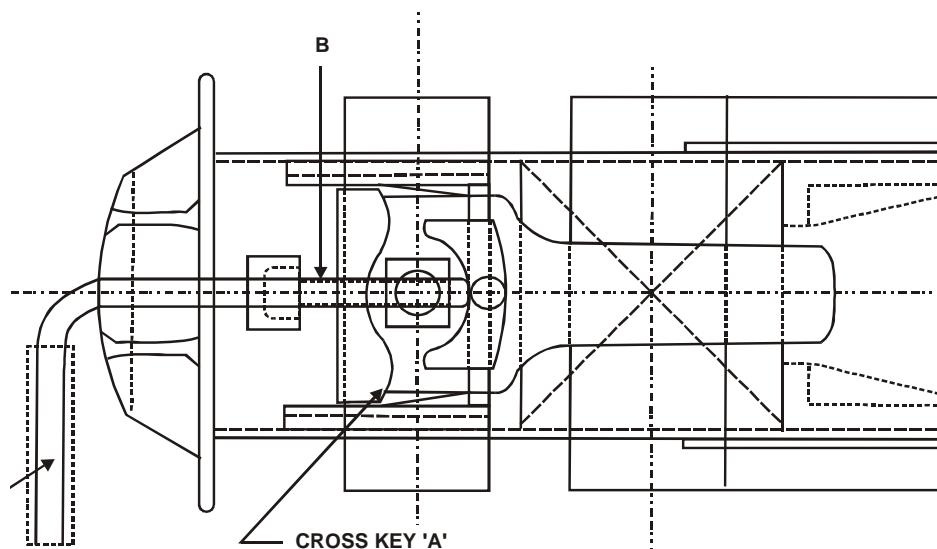
- A. Excessive slack in draft gears is not permitted and this should be either reduced or eliminated. The maximum permissible free slack in the draft gear is 25 mm(1") after which, it shall be removed and reclaimed or condemned. The free slack can be determined by first sledging the coupler back solid and then measuring the clearance between the coupler horn and the striker face. Next by inserting a long bar between the horn and striker face, pry coupler out

as far as possible and again measure the space between the horn and the striker. The difference between these two measurements is the amount of free slack.

- B. Visual examination of the rubber pads & coil springs when the draft gear is in place in the wagon can be misleading and the draft gears shall therefore be inspected at every POH of the wagon, irrespective of the amount of free slack existing.
- C. BOXN-HL and BCN-HL wagons are equipped with high capacity draft gears like "MINER SL-76 Draft Gears" etc. to RDSO specification No. WD-665-BD-06.

## 806. REMOVAL OF COUPLER AND DRAFT GEAR FROM WAGON

- A) Remove yoke pin support plate by conventional methods. Then remove the yoke pin. If necessary by inserting two chisels where the front follower bears hard against striker casting at the draft lugs.
- B) The coupler will now be loose and can be pulled out. Care must be taken to avoid personal injury as the coupler weighs over 200 Kg. and its head is heavier than the shank.
- C) Remove the yoke support plate by conventional means. When the gear is loose in the wagon pocket, the gear and yoke assembly must be supported by jacks or other means to avoid personal injury.
- D) To remove the gear and yoke assembly when the gear is tight in the wagon pocket, first apply cross key through front of yoke and position in yoke pinhole. Then apply screw B in cross key A and turn until contact is made with front follower of draft gear. With wrench C, turn screw with the aid of a piece of 38 mm (1 1/2") pipe until gear is loose in the wagon pocket. Remove wrench and lower the gear and yoke assembly on supports from the wagon pocket.



**FIG. 8.3**  
**REMOVAL OF DRAFT GEAR FROM WAGONS**

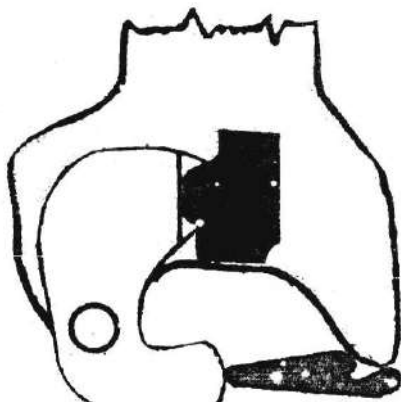
- E) To remove the draft gear from the yoke, compress the gear by means of screw and insert two pre-shortners as done during assembly. Then release the screw and remove draft gear.

## 807. CBC MEASURING GAUGES AND THEIR APPLICATIONS



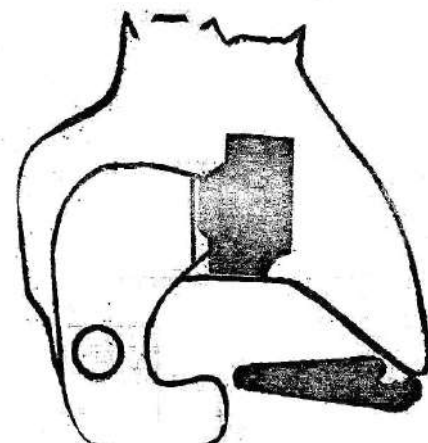
Contour Gauge No. 01 is used for checking of wear in guard arm and knuckle face of CBC. All wagons coming for ROH or POH are checked by this "not go" gauge

### A CHECKING OF GUARD ARM EXPANSION



GAUGE NO. 1

- Apply the gauge no. 1 as shown.
- If gauge no. 1 passes, renew
  - 1) Knuckle
  - 2) Knuckle pin
  - 3) Lock



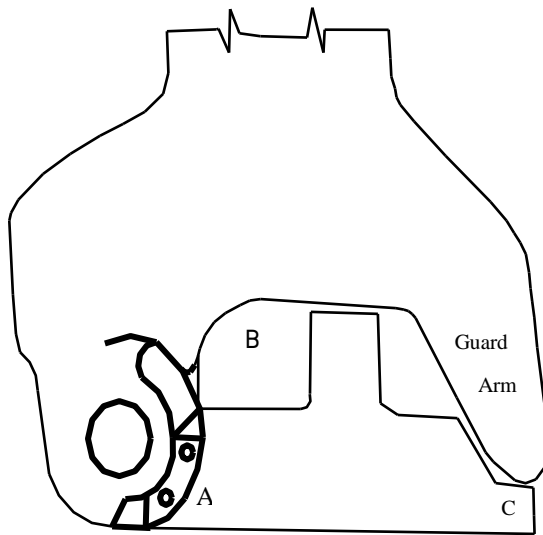
GAUGE NO. 2

- After replacing the above, if gauge no. 2 passes, renew the coupler body.
- **Reason - Guard arm expanded.**



Contour Gauge No.02 is used at outgoing wagon after repair in CBC unit. This gauge should not pass while putting between guard arm & knuckle.

**B CHECKING OF GUARD ARM DISTORTION**



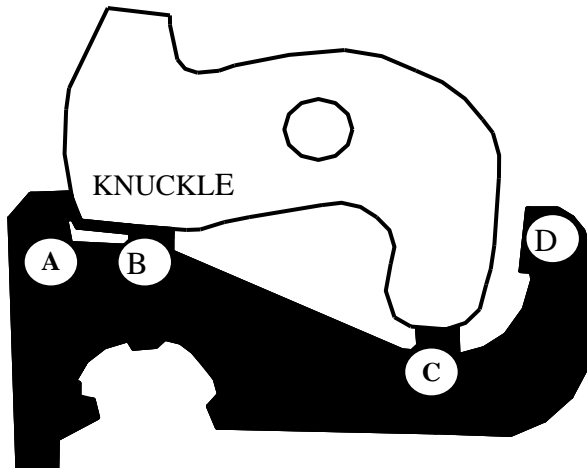
**Gauge No.3**

- Apply the gauge no. 3 as shown above.  
When 'A' is in contact, if 'B' or 'C' touches, renew the coupler body.
- **Reason : Guard arm distorted.**
- Note: If guard arm distortion is more than 4.8 mm, it should be closed into normal.



- Contour gauge-3 “Go and No Go type” for inspection in assembled condition

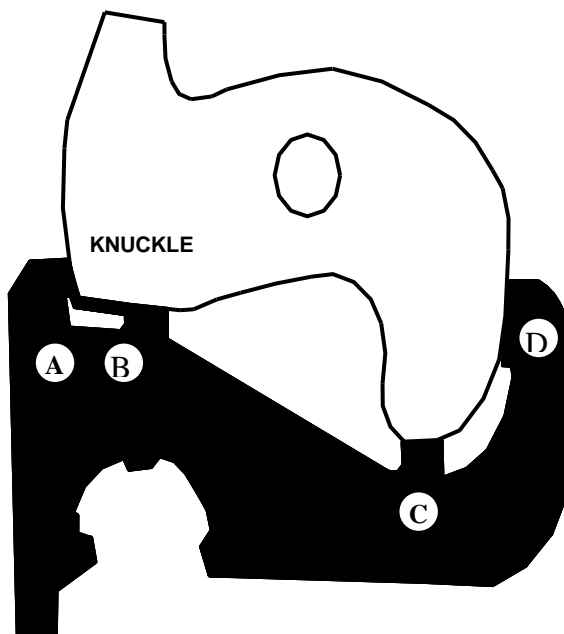
**C CHECKING OF STRETCHED KNUCKLE**



- Apply the gauge no. 4 as shown above.
- When A,B,C are in contact, there must be a clear gap at 'D'

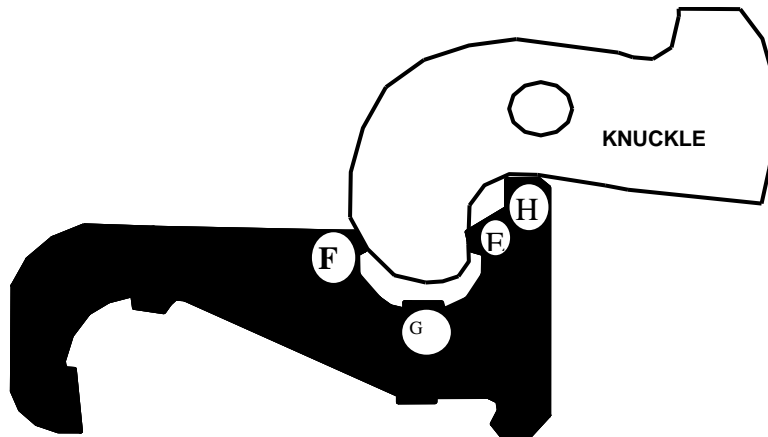


- Application of **Knuckle stretch and Nose wear gauge**

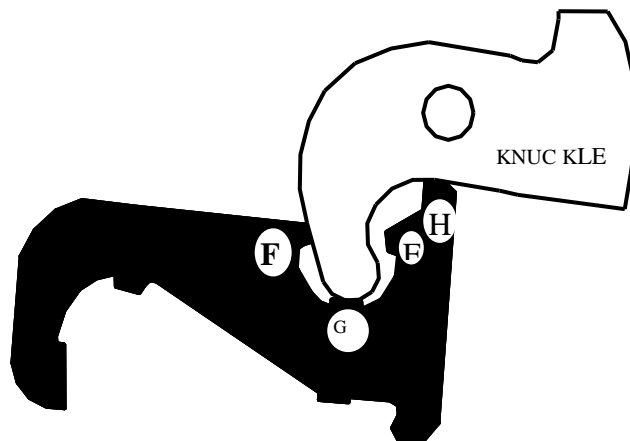


- If 'D' touches, renew the knuckle.
- **Reason – Knuckle is stretched.**



**D CHECKING THE KNUCKLE NOSE WEAR**

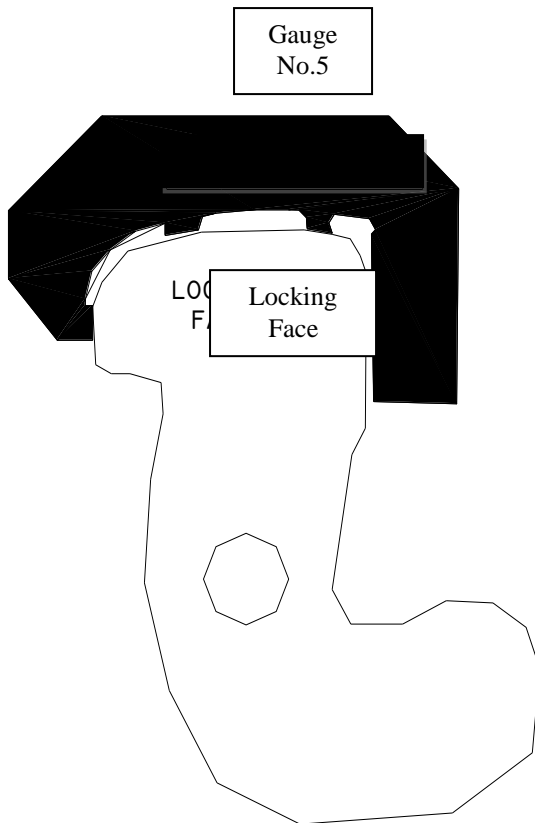
- Apply the gauge no. 4 as shown above.
- When E, F, G are in contact, 'E' must not pass.



- If 'E' passes, renew the knuckle.
- Reason – Excessive knuckle nose wear.



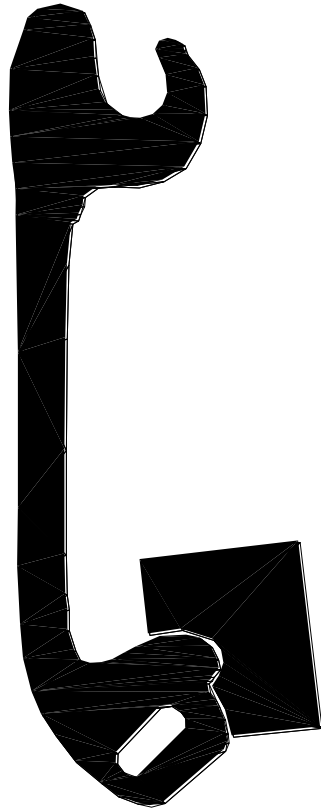
- Application of Knuckle pivot gauge \_GO Drg No.- 84073-47-RC

**E CHECKING THE KNUCKLE LOCKING FACE**

- Apply the gauge no. 5 as shown above.
- The gauge must not pass through vertically.
- If passes, renew the knuckle .
- **Reason : Excessive wear at locking face of the Knuckle.\**



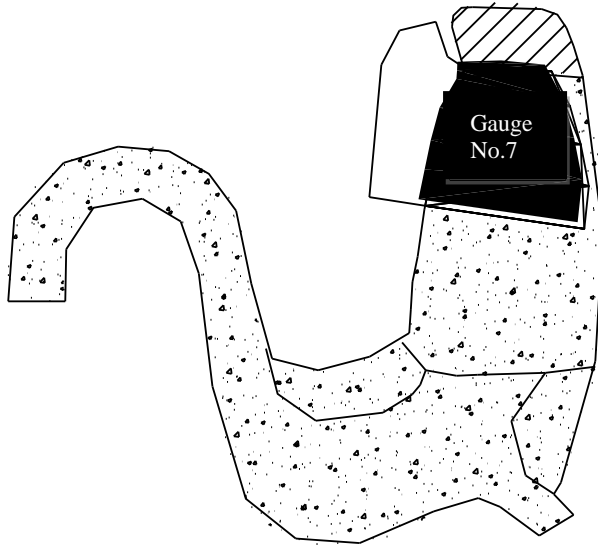
- **Application of Knuckle Profile gauge Gauge No. 05**

**F CHECKING OF ANTI-CREEP LEDGE OF BOTTOM LIFTER**

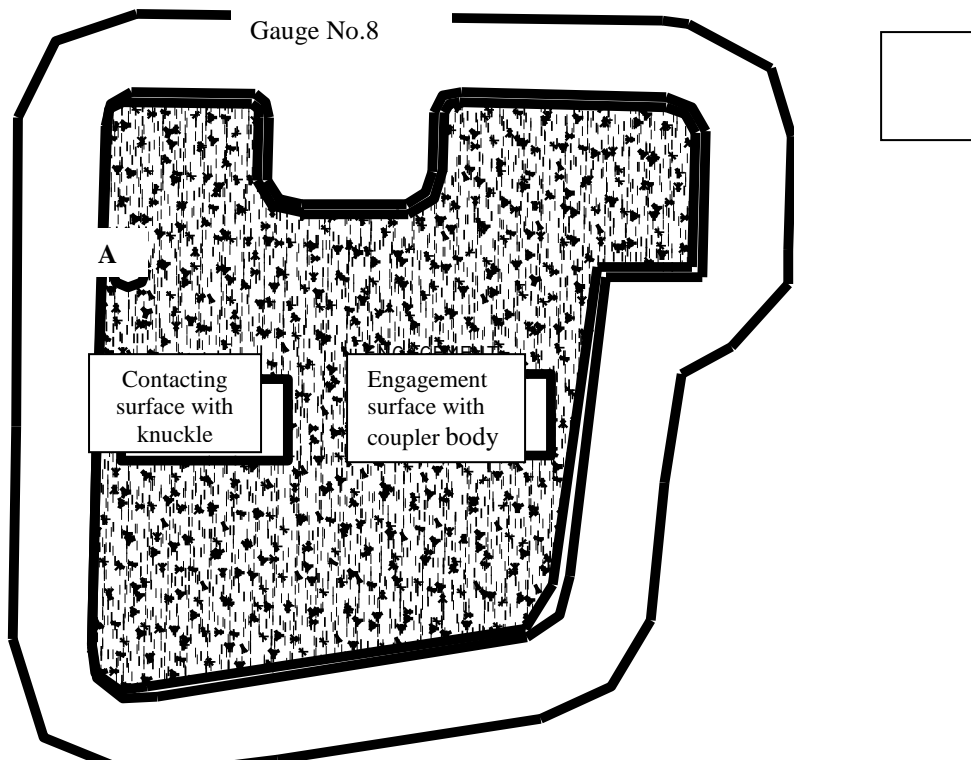
- Apply the gauge no. 6 as shown above.
- There should not be any clearance between gauge and bottom lifter.
- If there is a gap, renew the bottom lifter.
- **Reason : Ineffective anti –creep**



- **Application of Bottom anti-creep horizontal location gauge**  
Drg no.- WD-84073-S- 3-RC

**G CHECKING OF ANTI-CREEP LUG OF ROTARY LEVER**

- Apply the gauge no. 7 as shown above.
- If gauge is not mating properly with the anti –creep lug (bridge) of rotary lever , renew the rotary lever.
- **Reason : Ineffective anti -creep**

**H CHECKING OF LOCK WEAR**

- Apply the gauge no. 8 as shown above.
- When the surface 'A' is in contact, if the gap is more than 3.2 mm at 'B' , renew the lock.
- **Reason : There is a combined wear of lock at knuckle contacting surface & engagement surface with coupler body.**

**I. CHECKING OF SHANK LENGTH**



Shank length gauge Drg. No. WD-84073-S-22 –RC: Shank length is checked by this gauge

**J.CHECKING OF SHANK HEIGHT WITH WEAR PLATE GAUGE**



Shank height with wear plate gauge “Go” Drg No.-84073-S-21-RC:



Shank height with wear plate gauge No Go Drg No.-84073-S-21-RC: Shank height is checked with the help of this gauge

**K.CHECKING OF SHANK HEIGHT WITH WEAR PLATE GAUGE**



Shank wear gauge: wear in the plate is checked with this gauge

**L.CHECKING OF KNUCKLE PIN HOLE**



Knuckle pin hole gauge Drg. No.WD-84073-S-47-RC “No Go type”: Pin hole is checked by this gauge for wear limit



Knuckle pin hole gauge Drg. No. WD-84073-S-47-RC “No Go type”

**M. CHECKING OF PIVOT LUG**



Pivot Lug gauge No Go



Pivot Lug gauge Go

**N.CHECKING OF PIVOT PIN**



Pivot pin gauge Drg No.- 84073-S-8-RC



Pivot pin gauge Drg No.- 84073-S-8-RC



### O.CHECKING OF KNUCKLE PIN PROTECTION



Pin protector gauge- Drg. No. WD-84073 S-21-RC

Knuckle pin hole protection limit is checked with the help of this gauge to avoid breakage of

## 808. DEVELOPMENT OF HIGH TENSILE COUPLER & HIGH CAPACITY DRAFT GEAR

On BG system, to minimize the maintenance problem and to run heavy hauled freight train, the existing grade 'C' type coupler have been replaced to grade 'E' type coupler known as high tensile coupler. A comparative chart of grade 'C' and grade 'E' coupler is given below:

	Material		Ultimate		Yield strength	
	AAR M-201 & AAR M-211		Tensile strength (in tonnes)		( in tonnes)	
	STD.	HT.	STD.	HT.	STD.	HT.
<b>Coupler body</b>	Gr.B	Gr.E	290	408	169	205
<b>Knuckle.</b>	Gr.C	Gr.E	251	295	132	180

Standard CBC and high tensile CBC are identical in dimension hence no problem to couple each other. Draft capacity of the high tensile coupler also depends on the weakest link i.e. knuckle. The yield strength of the knuckle is 180t compared to 132t in standard coupler. The draft capacity of HT coupler is 36% higher.

The standard draft gears are to be replaced by high capacity draft gears vide Rly. Board's letter No.84/M(N)/172/3 Vol. I dt. 11.1.90 and 84/M(N)/172/3 dt. 5.7.90. And new freight stocks would be fitted with high capacity draft gears. At present three types of high capacity draft gears are in service

- **MK-50**
- **RF-361**
- **MINER SL-76** to RDSO specification No. WD-665-BD-06.

### A. COUPLER

- i. All bogie wagons manufactured prior to 1984-85 were fitted with HR-40-I or MF-400-I - IR draft gears but during shop schedules these are being replaced with high capacity draft gears progressively.
- ii. At present new freight stock are fitted with high capacity draft gear i.e. **RF-361 , MK-50 & MINER SL-76.**

### B. DESIGN FEATURES OF HIGH CAPACITY DRAFT GEARS

Type of Draft Gear	Wt. (kg)	Capacity (kg.m.)	Travel (mm)	Reaction force (tonnes)	Performance efficiency (%)	Energy absorption (%)
MK-50	170.3	5385	81.5	269.0	23.7	86
RF-361	138.0	5725	67.8	232.3	36.6	79.6

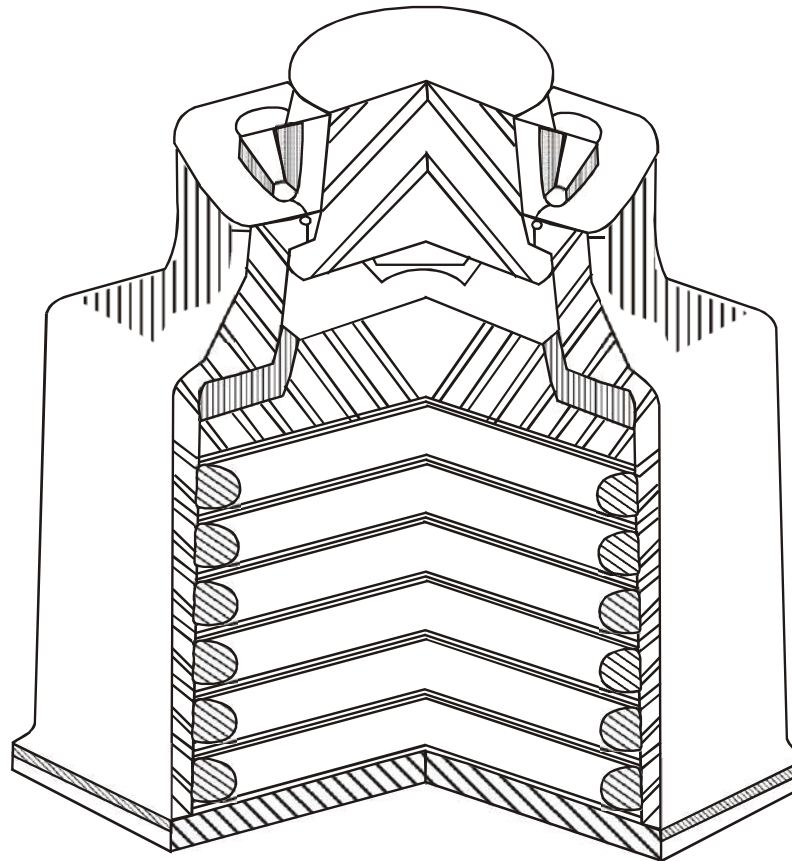
## 809. RF-361 DRAFT GEAR

This type of draft gear is a fully enclosed, self-contained unit assembled with pre-compression force of rubber pads, so that all parts are tight in relation to one another. Under normal service condition the draft gear is tightly fitted in yoke with front follower plate.

**Note :-** All the drawing no., part no. and gauge no. mentioned here under are as per literature of Burn Standard Co. Ltd., Howrah Works, titled “*INSPECTION AND MAINTENANCE MANUAL FOR HIGH CAPACITY DRAFT GEAR RF-361*”

### A. COMPONENTS OF RF-361 DRAFT GEAR

- Housing (cylinder)
- Wedge
- Shoes 3 nos
- Bore inserts
- Top follower
- Rubber pads (Elastomer unit)
- Rear wall plate



**FIG. 8.5: RF- 361 DRAFT GEAR**

**B. LIST OF GAUGES FOR RF-361 DRAFT GEAR****a. Gauges for housing:**

- Gauge - 27200 Profile gauge.
- Gauge \_ 27706
- Gauge \_ 27257 Flatness gauge.
- Gauge \_ 27244 Height gauge ( GO & NO-GO)

**b. Gauges for Shoes**

- Gauge - 27253
- Gauge \_ 27254
- Gauge \_ 27298
- Gauge \_ 27716

**c. Gauges for Wedge**

- Gauge - 27215
- Gauge \_ 27216
- Gauge \_ 27266
- Gauge \_ 27267

**d. Final Inspection gauges**

- Gauge - 27207 - Pre-shortened assembled gauge
- Gauge - 27739 - Box gauge

**C. MAINTENANCE**

a. The RF-361 draft gear will require complete reconditioning, i.e. removal and replacement of the rear wall plate only if the gear has loosed clutch components (shoes & wedges), a broken housing, or a cracked weld at the rear wall.

I. A loose clutch will normally mean that there is either a defective rubber springs package or excessive wear has taken place on the cylinder bore friction surfaces. With a loose clutch, the steel components will usually be moved by hand.

II. A cracked weld indicates poor welding practice during initial assembly causing a fatigue crack, or brittle weld which can fail under extremely high shocks loading etc.

III. If a loose clutch, broken housing, or a cracked weld are not present then only removal and replacement of clutch components is necessary. Normally, clutch disassembly and replacement is the only reconditioning needed in the RF-361 draft gear.

**b. DISASSEMBLY PROCEDURE FOR RF-361 DRAFT GEAR**

If either the shoes or wedge are broken and clutch is not loose, the following disassembly procedure can be used to replace the broken components.

- (I) The following equipment & special tools will be required to remove the shoes and wedge from the draft gear;
  - i. 200 tonnes vertical open gap press
  - ii. Assembly block Drg. No.27051
  - iii. Assembly Ring
  - iv. A wooden taper wedge plug for the old style hollow wedge or a 76 mm or 3" diameter industrial strength magnet with special long handle for the new solid wedge.
- (II) The press should be equipped with an appropriate ram press head to drg. no 27800 to facilitate removal operations.
- III. Place the assembly ring over the top outside of the friction bore of the cylinder. Put the assembly block inside the assembly ring so that its three slegs evenly contact the three shoes. Place the magnet on top of the solid wedge, its handle protruding through the hole in the assembly block.
- IV. Press down the assembly block compressing the shoes slowly into the gear. While continuing to press on the shoes grasps the magnet or wooden plug handle and rotate the wedge clockwise until the wedge lugs are completely clear of the housing lugs. The top of the shoes need to be almost even with the bottom of the housing lugs before the rotation can be accomplished. Once the lugs are clear to each other compression can be released and wedge and shoes can be removed.

**c. INSPECTION OF COMPONENTS****I. SHOES**

The shoe, which have to be reused must be free from the following defects.

- No concave wear on any friction surface
- No cracks or spalls
- No wear more than 0.8 mm or 1/32" on any friction surface

**II. WEDGE**

The wedges which have to be re-used must be free from the following defects.

- No crack or spall of the carburized case on the friction faces or the top of the wedge.
- No wear more than 0.8 mm or 1/32" on the friction surface.
- No indication of broken or any cracks on any of the locking lugs.

### III. HOUSING OR CYLINDERS

- The inside friction bore walls must be worn symmetrical and the wall thickness must not be less than 20.6 mm or 13/16"
  - There must not be any bottom ridging in the bore.
  - Bore taper should be smooth and any concavity must not exceed 0.8 mm or 1/32". There should not be broken lugs or cracks in the housing.
  - The housing should not be bulged outside.
  - The housing must pass through profile gauges No. 27706 and 27200.
  - Housing base flatness must meet gauge No. 27257.
- IV. To function properly, every part of the assembly must be free of oil, grease and moisture. The parts should be kept properly during storage, handling and re-assembly.
- V. Wedge and shoes are to be shot-peened to remove rust and dirt before assembly. Shot-peening also allows better visual examination. No sharp edges are to be permitted on these parts, since they could cause cutting and gouging.
- VI. For re-assembly, the assembly ring is first placed over the housing. The three shoes are put into position in the bore, and the wedge (with magnet placed over the shoes) with each wedge lug resting on the angled shoulder of a shoe. Next, the assembly block is put over the wedge carefully, pushing the shoes into the housing. When the top of the wedge lug has cleared the bottom of the housing lug, clockwise, the wedge will fall into place and the compression can be released, completing the assembly.

### D. COMPLETE RECONDITIONING

- a. If complete reconditioning of the gear is required either because of a loose clutch or a broken weld, the shoes and wedge must be removed from the gear in the manner that has been described above. This reduces the internal spring force of the gear stated above.
- b. The rear wall plate must be removed from the gear housing for complete dis-assembly. The gear should be mounted in a holding fixture incorporating a hydraulic press acting axially on the housing ends. Lock the hydraulic ram about 1/4" (6 mm) longer than the housing length so that

the rear plate will be able to separate from the housing during cutting. The press ram must be capable of resisting a force of 10 tons exerted by the rubber pad spring stack.

- c. Cutting of the rear wall plate can be done by an abrasive cut-off wheel, sawing or flame cutting. Make the cut just less than the 1 ¼" (32 mm) thickness of the rear wall plate.

#### **NOTE**

*If the flame cutting is used, adequate ventilation and air movement during the cutting must be provided. If there is a shortage of air during rubber burning, the rubber pyrolysis could create an explosive mixture.*

- d. Release the hydraulic ram to free the gear. Remove the rubber pads and internal follower from the housing.
- e. Inspect the housing and also the housing wall thickness at the bottom which must not be less than 11.9mm (or 15/32") and 19.8mm (or 25/32") respectively.
- f. **Inspection of Rubber pads**

- I. Reject pads which show tears, large material chunks, large bond failures, or extreme wear into the steel plate edges.
- II. Pads are gauged and must not be less than 2 ⅛" (54 mm) as measured by a gap gauge at the middle of each side.
- III. Bent (but not broken or cracked) steel plates are acceptable as these will straighten during assembly.
- IV. Creases and folds are normal and are acceptable for reconditioned gears.

#### **V. VISUAL INSPECTION OF RUBBER PADS**

- i. Full bonding to each of the metal is required.
- ii. Top and bottom surfaces of plates must be free of elastomer films or drops.
- iii. Inspection sprues must be 3.18 mm or 1/8" min. below the steel plate surface.
- iv. Pad must be free from cracks.
- v. Parting line flash should not exceed 0.78mm or 1/16".
- vi. Elastomeric material should be free from foreign material i.e., trapped air etc.
- vii. Check for proper markings.

**VI. STATIC TEST**

- i. Rubber pads must be inspected carefully. Hundred percent pads are inspected visually. Squeeze each pad to a height of 37 mm and check for bond failure, chunks cracks and bubbles. These defects are causes for rejection.
- ii. Check pads for bulge. Elastomer should not extend beyond the steel plates when squeezed to solid height.
- iii. Pad must be returned to minimum free height of 61 mm within one minute after load is released.
- iv. Pads must not be skewed after the load is released.

**g. INSPECTION OF INTERNAL FOLLOWER**

- I. Outside profile dimension must be at least 11<sup>1</sup>/<sub>4</sub>" x 7" (286mmx178 mm).
- II. Base must be flat within 1/16" (1.6mm) across the diagonals.
- III. Base and show support boss must be parallel within 1/16" (1.6mm).
- IV. Shoe wear indentations on the boss must not exceed 1/16" (1.6 mm).

**h. INSPECTION OF FORGED ITEMS**

- I. Parts will be visually inspected for seams laps, scale pits, improper grinding and other defects.
- II. All items should be checked for proper and distinct markings which should be legible.
- III. Parts are to be gauged for dimensional checking.
- IV. Some dimensions are checked with calipers scales or other measuring instruments as required if gauges do not exist or not available.

**i. INSPECTION OF HOUSINGS (CYLINDERS)**

- I. Housings or cylinders must not have excessive porosity, surface discontinues shrinkage and inclusions.
- II. proper gauges should be used to ensure sufficient yoke clearance and for checking rear wall flatness.

**j. PREPARATION OF HOUSING PRIOR TO RE-ASSEMBLY**

- I. The housing is placed bore end down on a flat metal work table next to a flame cutting fixture. An accurate flame cut may be achieved by using either a guided torch nozzle which moves along the stationary housing length at a fixed height, or by moving the housing past a fixed torch nozzle.



- II. The housing is to be cut to a length of  $463.6 \text{ mm} \pm 1.6 \text{ mm}$  ( $18 \frac{1}{4}'' \pm 1/16''$ ). It is important to regularly clean the torch tip to help ensure a clean and accurate cut.
- III. After each side is cut, the housing is hit with a hammer to remove slag. The work table and guides should be swept clean of slag after each cut to ensure a level cutting surface and proper height position for the following cuts. The housing can be rotated by hand before cutting on a new side.
- IV. Check the finished housing (cylinder) height using gage no 27244.
- V. Grind after cutting with a hand grinder to;
  - v Remove flame cutting marks back to clean steel
  - v Remove slag deposits on the housing
  - v Bring correct size to the finished length.

## **E. RE-ASSEMBLY OF RE-CONDITIONED RF-361 DRAFT GEAR**

### **a. Tools required**

- 50 t vertical press
- Draft Gear assembly ring support fixture.

- b. For re-assembly, the assembly ring is first placed over the housing. The three shoes are put in position in the bore and the wedge is placed over the shoes, with each wedge lugs resting on the angled shoulder of the shoes. Next, the assembly block to drg. No.27051 is put over the wedge, so the legs of the assembly block contact the top of the shoes. Press down very slowly and carefully, pushing the shoes into the housings. When the top of the wedge has cleared the bottom of the housing lugs either by tapping the handle or slightly rotating it clock-wise, the wedge will take its position in place and the compression can be released.

## **F. INSPECTION OF RECONDITIONED DRAFT GEARS RF-361**

Draft gear shall be visually inspected for the following characteristics:-

- Inserts - one insert per lug properly located and intact in position.
- Shoes - must be properly positioned with respect to the wedge.
- Housing - must be free from cracks lumps and other defects. Components must be properly seated. Clutch components must be tight.

## **G. WELDING OF REAR PLATE AFTER ASSEMBLY**

- a. After the weld zones of the housing and rear wall plate have been suitably preheated, the heating gas is to be turned off, and the heating ring is to be removed from the housing.
- b. Place the remaining two RF-8 rubber pads on the pad stack. These pads will be projecting above the rear of the housing.
- c. Place the preheated rear wall plate on top of the rubber stack and position it as closely as possible so the edges of the plate align with the edges of the housing.
- d. Position on draft gear assembly so that it is centered directly under the ram of the press (50 tonne vertical press). This is done to ensure even loading and square closure.
- e. Compress the rear wall plate down until it is firmly and squarely in contact with the housing base. Check the alignment of the rear wall plate sides in relation to the housing base sides. If necessary, release the press pressure, reposition the plate and compress again until the sides of the two pieces are aligned. It may be necessary to do this a number of times, depending on the skill and experience of the operator, till the proper alignment is obtained.

## **H. ROOT RUN WELDING**

- a. With the rear wall plate firmly held in place under the press, a root run, approximately 6.4 mm-7.9 mm (1/4"-5/16") in depth is made completely around all four sides. It is very important to obtain complete fusion and penetration into the full depth of the weld preparation.
- b. MIG welding with AWS A5.18-69 class E70S-1B, 1.14 mm (0.45") diameter, 100,000 psi tensile wire is used. Preferable shielding is a 75% Argon and 25% CO<sub>2</sub> gas. Wire feed speed is 45.7-50.8 cm (18-20 inches) per minute and the welding machine to be set for 250 - 280 amps. 26-32 volts.
- c. When the root run has been completed, the gear is removed from the press and moved aside. Inspect, to be sure that it is free of any visible defects. A total of three to four gears can be accumulated in this manner before filler pass welding is done.

## **I. FILLER PASS WELDING**

- a. The accumulated root run welded gears are placed side by side on a holding table, which is either flat or slightly tilted up to permit down hand welding of the filler pass.
- b. Use MIG welding with the same wire as used in the root run. 100% CO<sub>2</sub> shielding gas is used in the fill pass. The wire feed is 2300mm-3540mm (90-100 inches) per minute, at 250-280 Amp and 26-32 Volts.
- c. Weld one side of each of the accumulated gears.
- d. Turn each of the gears 90 degree and weld the second side of each gear. Continue this process till all 4 sides have been welded. The

fill pass should leave a weld bead that protrudes just above the housing surface.

- e. All welds are to be ground flush. The finished gear assemblies are then box gauged with Gage 27200 for dimensional acceptability.

## **J. PRE-SHORTENING & PAINTING**

The assembled RF-361 draft gear must be pre-shortened to facilitate installation into the yoke and draft pocket.

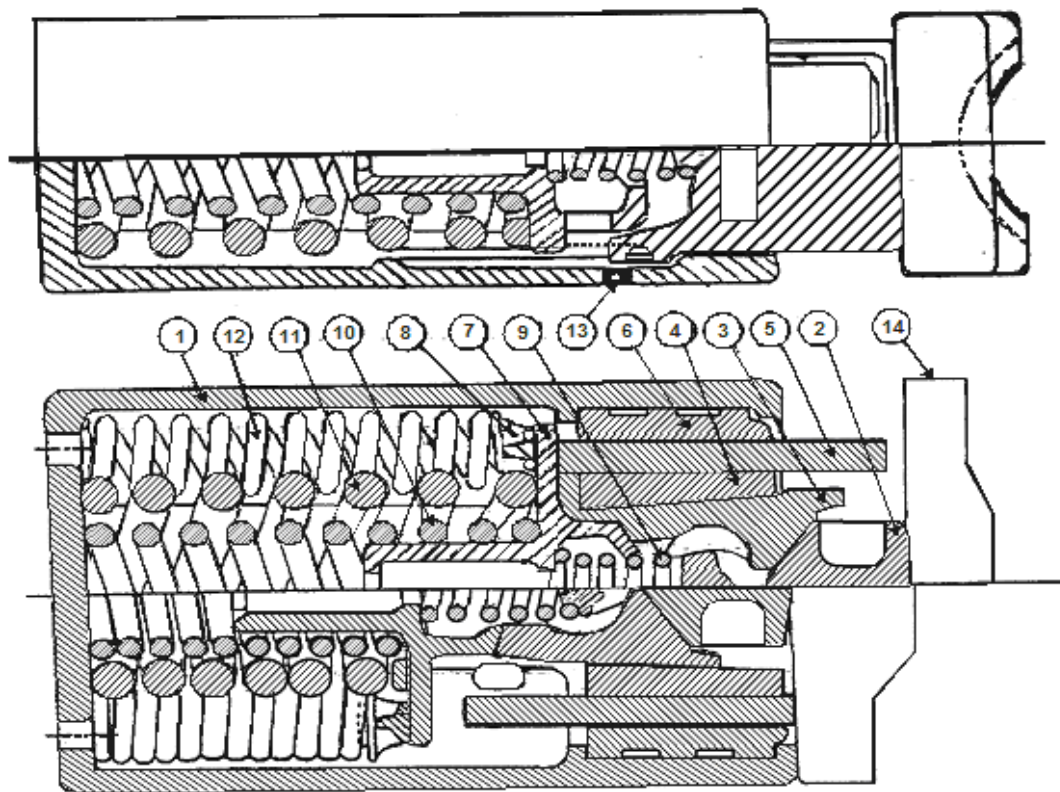
- a. Place the gear under a 200 ton open gap press, position the pre-shortening block (Drg. no 25658) on the shoes and apply a load. Compress the gear until there is sufficient vertical clearance between the housing and wedge lugs to insert standard powdered metal. Attach tap to 3 inserts (cube) using taps lower inserts through openings.
- b. Check the pre shortened length (using gauge 27207)
- c. After pre-shortening the external surfaces of the draft gear is to be painted with black or blue paint.

## **810. MAINTENANCE OF MARK-50 DRAFT GEAR**

**Note:** - All the drawing no., part no. and gauge no. mentioned hereunder are as per literature of M/s BESCO.

### **A. INSPECTION**

- a. The draft gear shall be inspected whenever wagons are coming in ROH depot. The following instructions shall be followed to determine whether draft gear is in normal released condition or in stuck condition.
- b. A normally released draft gear would appear as shown in Fig 8.6, where the follower plate is against the front lugs, the housing is against the rear lugs and the components of the friction clutch are fully returned to their neutral position. The internal spring forces in a normal fully released Mark 50 draft gear will be from 7,000 kg to 10,000 kg.
- c. It is possible for a slight gap to be seen at either the front or rear draft lugs when the draft gear is in a normal fully released position, e.g. in an enlarged draft gear pocket.



**Fig. 8.6: RELEASED DRAFT GEAR**

- |                             |                        |
|-----------------------------|------------------------|
| 1. HOUSING                  | 8. CORNER SPRING SEAT  |
| 2. CENTRE WEDGE COMPLETE    | 9. RELEASE SPRING      |
| 3. WEDGE SHOE COMPLETE      | 10. INNER COIL SPRING  |
| 4. TAPERED STATIONARY PLATE | 11. OUTER COIL SPRING  |
| 5. MOVABLE PLATE            | 12. CORNER COIL SPRING |
| 6. OUTER STATIONARY PLATE   | 13. SHORTING DEVICE    |
| 7. SPRING SEAT              | 14. FOLLOWER           |

## B. REMOVAL OF DRAFT GEAR FROM WAGON POCKET

When a draft gear with follower plate is installed into the pocket of a wagon, it has ample initial spring load to provide a tight fit into the draft gear pocket. While removing the draft gear from the wagon pocket, it is necessary to compress the draft gear approximately 6.35 mm (1/4"). In order to clear the front and rear stops, a suitable device can be used to compress the draft gear so that the draft gear and Yoke assembly may be free to be lowered from the wagon.

### a. NORMAL CONDITION

- I. Remove yoke pin support. Drop yoke pin down and draw coupler out of wagon.
- II. Place suitable lifting/lowering jack under yoke support plate. Holding yoke support in position with centre-sill, cut and take out rivets.
- III. Insert nut (Ref: RDSO manual G-80) in the yoke pin hole. Apply screw from the mouth and compress by rotating screw

by means of wrench so that the draft gear with follower is clear of the pocket length by about 6 to 8 mm.

- IV. Lower support at yoke support plate and take out yoke with draft gear and screw.
- V. Unscrew and remove nut. Now draft gear, follower is loose in yoke and they can be taken out separately.

**b. FOLLOWER BROKEN**

A broken follower will remain within pocket only if it is cracked at centre and split in two at centre vertically or horizontally.

When cracked and split jerk by hammer or by pulling yoke forward to loosen the follower in the pocket.

**c. PARTIALLY STUCK GEAR**

In a partially stuck draft gear, the draft gear is loose in the pocket and the draft gear travel will be less than 82.55 mm (3-1/4”).

**d. FULLY STUCK DRAFT GEAR**

A fully stuck draft gear is one where the components of the friction clutch are jammed and flush with the open end of the housing. A large gap would appear at the front or rear stops or at both stops.

The internal spring forces between 11,000 kg and 23,000 kg would propel the friction parts outward if the gear was to suddenly release.

**e. REMOVAL OF STUCK OR DAMAGED DRAFT GEAR**

**WARNING:**

**WEAR SAFETY EQUIPMENT INCLUDING HARD HAT, SAFETYGLASSES, SAFETY SHOES, GLOVES AND BODY PROTECTION**

**I. When follower is not missing**

**DO NOT STAND OR WORK DIRECTLY IN FRONT OF COUPLER**

- i. First move another wagon against the couple, forcing follower and draft gear against rear stops. Do not remove the yoke support plate. Securely weld draft gear housing and follower.
- ii. Cut gear housing in spring area to expose coil springs and cut each coil of every spring to eliminate the compressive force or the springs.

**II. Where yoke is broken and follower is missing**

- i. First move another wagon against coupler forcing draft towards the stops as far as possible.
- ii. Remove a section of the yoke straps with the torch to permit installation of a follower and bracket

***IMPORTANT: The follower with the bracket must be installed with a lift table or fork truck to eliminate any one putting their hands near the open end of this stuck draft gear. Once fitted into place,***

- i. Securely weld the bracket to the draft gear housing.
- ii. Remove coupler.
- iii. Position lift table or other lowering means under the support plate, yoke and draft gear.
- iv. Remove rivets from yoke support plate. Slowly lower down the assembly unit on the ground.
- v. Scrap draft gear, yoke and follower.

**C. REMOVAL OF STUCK DRAFT GEAR SO AS TO REUSE**

In case it is desired not to gas cut and scrap stuck draft gear as above, the following procedure may be adopted:-

- a. Place the stuck draft gear in front of a wall or 50 to 75 mm facing another working draft gear with follower. Force compressed air to clean any dust or mud from draft gear.
- b. Give sledge hammer blows with 8-10 kg hammer on the top front, side fronts, edges and rear wall. The inside components will be forced out. Re-examine this draft gear for any broken or unserviceable part. Re-use or reclaim the draft gear for use.

**D. INSPECTION OF MARK-50 DRAFT GEAR FOR RECONDITIONING**

Mark-50 draft gears have a built in wear life gauge. This is known as "plate clearance" and can be observed by looking up at the gear while it is in the wagon. When the draft gear is out of the wagon a straight edge can be placed on the centre wedge of draft gear. Both movable plates should be driven or forced down until solid before measurement is made. The plate clearance is an indicator of the total surface wear of the friction components. When the plate clearance reduces to zero, the draft gear loses its effectiveness to cushion. Once the draft gear reaches this stage, some of the parts will start wearing on the housing and cause considerable damage, rendering it impossible to recondition. Cardwell recommended that Mark-50 draft gear should be inspected whenever wagon is in shop or under repair or when the draft gears are removed from the wagon.

**E. SUMMARIZED GUIDE TO DISMANTLE MARK-50 DRAFT GEAR**

- A press of 40 tonnes is required.
- Press down with fixture D and insert the two pins.
- Remove movable plate one side.
- Remove wedge shoe same side.
- Remove movable plate other side.
- Remove wedge, shoe other side.
- Turn and remove centre wedge.
- Remove release spring.
- Remove both tapered stationary plates.
- Remove both outer stationary plates.
- Apply fixture C and press to remove pins.
- Remove spring seat.
- Remove all coil springs and corner spring seats.
- Reverse procedure for assembly.

**F. List of Gauges For Mk-50 Draft Gear*****a. Housing Gauges For Initial Inspection***

- I. Housing reconditioned gauge No. BE-91/62-2 (No-Go Gauge to check minimum length of housing)
- II. Housing reconditioned Gauge No. BE-91/62-1 (GO Gauge to check maximum housing for Yoke and Sill clearance).
- III. Housing reconditioned Gauge No. BE-92/62-6 (No GO Gauge to check minimum housing wall thickness)
- IV. Housing reconditioned bottom flatness check

***b. Housing Weld Repair Gauges***

- I. Reconditioned gauge No. BE-91/62-5 (No-Go Gauge to check to centre wedge stop area)
- II. Reconditioned gauge No. BE-91/62-3 (Go, No-Go Gauge to check movable plate area)
- III. Reconditioned gauge No. BE-91/62-4 & 5 (Go, No-Go Gauge to check on the wedge area)
- IV. Centre wedge gauging gauge No. BE-91/61-1
- V. Spring seat gauging gauge No. BE-91/61-5
- VI. Gauging centre wedge and spring seat for sorting gauge No. BE-91/72-1.
- VII. Tapered stationary plate gauge No. BE-91/61-4
- VIII. Outer stationary plate gauge No. BE-91/61-3
- IX. Wedge shoe gauge No. BE-91/61-2.
- X. Gauging springs inner coil, corner coil & release gauge No. BE-91/61-7 & 8
- XI. Outer coil gauge No. BE-91/61-6
- XII. Corner spring seat reclamation.
- XIII. Movable plate gauging gauge No. BE-91/61-10

**Note:** There are two maintenance publications i.e. G-76 for lines staff and G-80 for workshop staff issued by RDSO on “Inspection and Maintenance of Centre Buffer Couplers BG stock”. For Alliance-II CBC, RDSO has issued G-62 for inspection and maintenance by Train Examining and Workshop staff.

## 811. Action plan to reduce Train Partings:

A report on analysis of train parting was circulated by Railway Board vide letter No. 2012/m(n)/951/35 dated 14.09.2012 to Zonal Railways. This report highlighted that approx. 62% cases of train parting were due to uncoupling and approx. 38% due to breakages of components. The uncoupling cases were mainly due to lock defective/broken, lock lifting arrangement defective, knuckle worn out/defective and operating handle/bearing bracket defective. The components breaking were knuckle, CBC body/Shank and Yoke.

*This Report had the following recommendations –*

1. Zonal Railways should strictly check and enhance replacement of knuckles, knuckle pivot pin, lock , lock lifter with toggle, yoke pin, operating handle and bearing piece during POH, ROH, Sick line and Yard maintenance.
2. DPT Test of knuckles during ROH.
3. Improve maintenance standard of CBC and Draft gear components.

*Vide Railway Board's letter No. 2003/M(N)/951/22 dated 16.01.2013, List of must change items have been recommended during POH and ROH.*

- A. During POH: Knuckle, CBC lock, Rotary lock lift assembly, bearing piece , yoke pin support plate liner and shank wear plate etc.
- B. During POH & ROH: Striker casting wear plate
4. Railway should send Report of every train parting to RDSO as per RDSO Proforma (Ref : RDSO letters Nos. MW/CPL/VG/D dated 11.05.2010 & 05.04.2013).
5. RDSO should also put up their analysis for train partings on Rail net every month (similar to hot axles) for a feed back to work shops, ROH depots and examination points.



**VENDOR LIST**  
**(As on 01.01.2013)**  
**(CENTRE BUFFER COUPLER)**

**1. HIGH TENSILE CBC COUPLER & ITS COMPONENTS FOR FREIGHT STOCK (SPEC-48-BD-08)**

1.	BESCO Ltd. 7B & C Poonam, 5/2 Russel Street, Calcutta-700001
2.	Bhilai Engg. Corp. Ltd. Post Box No. 31, Industrial Area, Hathkhoj Village, Bhilai-490001
3.	Braithwaite & Co.Ltd. Angus works, P.O. Angus Distt-Hoogly-712221
4.	Burn Standard Co. Ltd. Nityadhan Mukharjee Road, Howrah-711101
5.	Hindustan Engg. & Industries Ltd.. 27, Sir R.N. Mukharjee Road, Calcutta-700002
6.	Raneka Industries Ltd. Plot No. 17, Sector III, Sagore, Pithanm pur, Distt. Dhar M.P.
7.	Texmaco Rail and Engineering Ltd.(Steel foundary) Belgharia , 24 Paragana, Calcutta-700 056
8.	Titagarh Wagon Ltd. (Unit: Titagarh steel) 113, Park Street, Calcutta-700 016.
9.	Jupiter alloys & Steel (India)Ltd.
10.	Fronteir alloy & Steel Ltd.,
11.	Titagarh Wagon Ltd. Heavy Engineering Division (TWL)
12.	Siena Engg. PVT. Ltd.
13.	Rine Engg. Pvt. Ltd.
14.	Chittaranjan Locomotive Works, steel foundary, Chittaranjan
15.	Rausheena Udhog Limited, Engineering Division

**2. HIGH TENSILE CBC COUPLER & ITS COMPONENTS FOR LOCOMOTIVE (SPEC-56-BD-07) with amend No.1 of 10 & drawing no. SKDL-3430**

1.	BESCO Ltd. 7B &C Poonam, 5/2 Russel Street, Calcutta-700001
2.	Chittaranjan Locomotive Works, steel foundary, Chittaranjan
3.	Hindustan Engg. & Industries Ltd. 27, Sir R.N. Mukharjee Road, Calcutta-700002
4.	Orient Steel Industries Ltd. 2, Brabourne Road, Calcutta-700001
5.	Raneka Industries Ltd. Plot No. 17, Sector III, Sagore, Pithanm pur, Distt. Dhar M.P.
6.	Texmaco Rail and Engineering Ltd.(Steel foundary) Belgharia , 24 Paragana, Calcutta-700 056
7.	Titagarh Wagon Ltd. 113, Park Street, Calcutta-700 016.
8.	Jupiter alloys & Steel (India) Ltd.
9.	Frontier alloys & Steel Ltd.

10.	Titagarh Wagon Ltd. (Heavy Engg.)
11.	Siena Engg. Pvt. Ltd. Plot No. 5-3/3 & 22, Sector (iii), Pithampur, Distt. Dhar. M.P.

### 3. ALLIANCE II COUPLER & ITS COMPONENTS (SPEC-24-BD-79)

1.	BESCO Ltd. 7B &C Poonam, 5/2 Russel Street, Calcutta-700001
2.	Raneka Industries Ltd. Plot No. 17, Sector III, Sagore, Pithanm pur, Distt. Dhar M.P.
3.	Titagarh wagon Ltd.(unit titagarh steel) 113, Park Street, Calcutta-700 016.
4.	Siena Engg. Pvt. Plot No. 5-3/3 & 22, Sector (iii), Pithampur, Distt. Dhar. M.P.

### 4. HIGH CAPACITY DRAFT GEAR (SPEC-49-BD-08) & drawing no. WD-81010-S-03(Alt-9)

1.	BESCO Ltd. 7B &C Poonam, 5/2 Russel Street, Calcutta-700001	MK 50 Cardwell design
2.	Burn Standard Co. Ltd. Nityadhan Mukharjee Road, Howrah-711101	RF-361 Miner design
3.	Hindustan Engg. & Industries Ltd. . 27, Sir R.N. Mukharjee Road, Calcutta-700002	RF-361 Miner design
4.	Titagarh Wagon Ltd. 113, Park Street, Calcutta-700 016.	RF-361 Miner design
5.	Texmaco Rail and Engineering ltd steel foundary kolkata.	RF-361 Miner design
6.	Braithwaite & Co.	RF-361 Miner design
7.	Frontier alloys Steel Ltd.	RF-361 Miner design
8.	Jupiter alloys & steel (India Ltd)	
9.	Raneka Steel Ltd.	
10.	Bhilai Engg. Company Ltd.	

### 5. TOP LOCK LIFT HOLE CAP (SPEC 48-BD-08)

1.	Annpurna Engg. Works, 89/1, Deshprn, Sasmai Road, Howrah-711 101
2.	Comet Technocom (P) Ltd. 37, Bhagwan Ganguly Lane, 3 <sup>rd</sup> floor, Howrah-1
3.	Decon India, 9 Duffer Street, Liluah, Howrah-4
4.	Krishna Engg. Works, 57/9, Q Road, Netajigarh, (Belgachia) Howrah
5.	Shiv Engg. Woprks, 64/4, G.T. Road, Liluah, Howrah
6.	AD. Electro Steel Co-Pvt Ltd. Balti kuri (Surki mill) Howrah

7.	Him Teknoforge Ltd. Village-Bhillanwali, Industries Area, Baddi (H.P.)
8.	Devvrat Industries Co. Jalan Complex, Junglepur NH-6 Mouza Baniara, P.O. Donjur, Howrah,

**6. KNUCKLE PIN WITH WASHER (SPEC 48-BD-08)**

1.	Anand Sales Corporation 6 Poonam chand Bagaria Belly, Howrah-711005
2.	Annpurna Engg. Works, 89/1, Deshpri, Sasmai Road, Howrah-711 101
3.	Comet Technocom (P) Ltd. 37, Bhagwan Ganguly Lane, 3 <sup>rd</sup> floor, Howrah-1
4.	Cosmic Engineers, 2, Duffer Road, Liluah, Howrah-711202
5	Krishna Engg. Works, 57/9, Q Road, Netajigarh, (Belgachia) Howrah
6	Lal Baba Industrial Corporation 78, Lalababu Shir Road, Belur, Howrah- 711 202
7	Melbro Engineering Works Pvt.Ltd., 1/1, "X" Road, Belgachia, Howrah
8	NF Forging Pvt Ltd. 72, Lalababu Shire Road, Belur, Howrah 711202
9.	Royal Industries, 8, Kali Mazumdar Road, Ghusuri, Howrah 711107
10.	Aglow Engg. Howrah-Amta Road Salap, Howrah 911409.
11.	S.K. Industries, Ichapur,P.o.Santragachi, Howrah-4
12.	Shree Engineers Ichapur H.I.T. Road, Santragachi Hawrah-4
13.	AD. Electro Steel Co.Pvt. Ltd. Balti kuri (Surkimill) Howrah
14.	Devvrat Industries Co. Jalan Complexm, Junglepur, NH-6 Mouza: Baniara, P.o-Donjur Howrah-711411.

**8. YOKE PIN (SPEC 48-BD-08)**

1.	Anand Sales Corporation 6 Poonamchand Bagaria Belly, Howrah-711005
2.	Annpurna Engg. Works, 89/1, Deshpri, Sasmai Road, Howrah-711 101
3.	Comet Technocom (P) Ltd. 37, Bhagwan Ganguly Lane, 3 <sup>rd</sup> floor, Howrah-1
4.	Cosmic Engineers, 2, Duffer Road, Liluah, Howrah-711202
5.	Krishna Engg. Works, 57/9, Q Road, Netajigarh, (Belgachia) Howrah

6.	Lal Baba Industrial Corporation 78, Lalababu Shir Road, Belur, Howrah- 711 202
7.	Melbro Engineering Works Pvt.Ltd., 1/1, "X" Road, Belgachia, Howrah
8.	N.F. Forging Pvt. Ltd., 72, Lalbabu Shiv Road, Brlur, Howrah- 711 202
9.	India Tools Craft Pvt Ltd.Hawrah Industries Estate, dhed No.34835 (L type) Dasnagar Howrah.
10.	Devvrat Industries Co. Jalan Complex, Junglepur-NH6, Mouza= Baniara, P.o. Donjur Howrah.
11.	AD Electro steel Co. Pvt. Ltd.
12.	Aglow Engg. Howrah-Amta Road Salap, Howrah 911409.
13.	Royal Industries, 8, Kali Mazumdar Road, Ghusuri, Howrah 711107

### 9. KNUCKLE THROWER (SPEC 48-BD-08)

1.	Annpurna Engg. Works, 89/1, Deshprn, Sasmai Road, Howrah-711 101
2.	Krishna Engg. Works, 57/9, Q Road, Netajigarh, (Belgachia) Howrah
3.	Lal Baba Industrial Corporation 78, Lalababu Shir Road, Belur, Howrah- 711 202
4.	AD. Electro Steel Co-Pvt Ltd. Balti kuri (Surki mill) Howrah
5.	Him Technoforge
6.	East India Steel Pvt.Ltd. Industrial Aria, Roulkela-769004.

**Note:** the above vendor list is only indicative and updated by RDSO after every Six Months. The current status of the vendors may be taken from vendor directory available on the RDSO website.



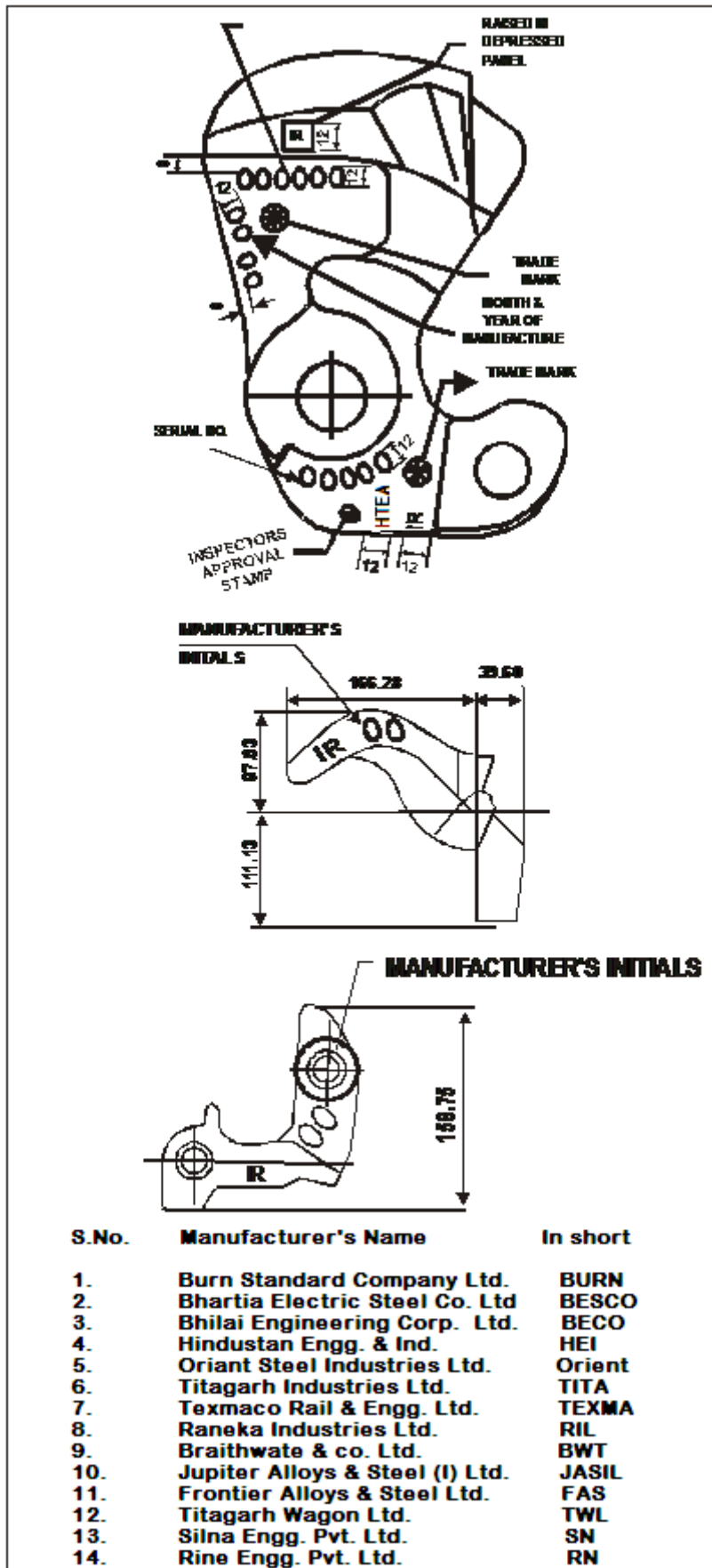


FIG. 8.14: MARKING OF PARTS

*( MAINTENANCE MANUAL FOR WAGONS- 2015 )*

# CHAPTER – 9



# TANK WAGON





## CHAPTER 9

# TANK WAGON

Tank wagons form a special class of non-pooled rolling stock. They are classified according to the product carried by the tank and its design. Tank wagons fall in the following categories:

- Tanks as pressure vessels.
- Tanks for corrosive liquids.
- Tanks for petrol and other highly inflammable products.
- Tanks for middle distillates of petroleum and others products.

For information about these wagons in respect of their mechanical code and the products carried, refer to Appendix “B” of IRCA Part III (Latest edition).

Since the population of four wheeler tank wagons and tank wagons on UIC bogies have been phased out, details of these stocks have not been included in this manual. If required, 2001 version of WMM may be referred.

### 901. CONSTRUCTIONAL DETAILS

#### A. Underframe

The design of the underframe of four wheeled and eight wheeled wagon is generally similar to that of other IRS wagons except that a pair of saddles is provided on the underframe at each end for mounting the barrel. Refer to Chapter 5 for repair and maintenance of underframe.

#### B. Barrel and saddles

The barrel is cylindrical vessel generally fabricated out of low carbon structural steel to IS:2062 Fe 410CuW. Material specifications for various types of tanks are given in Table-9.1. The barrel is placed longitudinally on the underframe and secured by means of rivets/welding to the saddle. The saddle is welded on underframe at each end.

**TABLE 9.1**  
**MATERIAL SPECIFICATION**

SN.	Type of wagon	Cylindrical portion	Dished ends
01	Ammonia tank wagon type BTALN, BTALNM	Steel.toBS:1501- 224Gr.32ALT 50 or ASTM-516Gr-70	Steel to BS:1501-224- Gr.32 A LT 50 or ASTM-516 Gr.-70
02	Liquified petroleum gas tank wagon type BTPGLN	Steel to BS: 1501-224- Gr32 A LT 30 or ASTM-516 Gr. 70	Steel to BS: 1501-224- Gr32 A LT 30 or ASTM-516 Gr. 70
03	Petrol tank wagons type BTPN	IS:2062 Fe410Cu-WA	IS:5986 Fe360 Cu
04	Heavy oil tank wagon BTOH	IS:2062 E250CU	IS:5986Fe360cu
05	Petrol tank wagon type BTFLN	IS:8500 Fe 570B	IS:8500Fe570B
06	Caustic soda tank wagon type BTCS	IS:2062 Fe-410CuWA	IS:5986 Fe-360 Cu
07	Tank wagon for phosphoric acid type BTPH	ASTM A 240 55 316 L	ASTM A 240 55 316 L

### C. Barrel mountings and safety Fittings

Various types of barrel mountings are necessary for filling, measuring and decanting depending upon the product handled. Safety fittings are generally provided inside the dome on a diaphragm plate so as to protect them from accidental injury. These fittings as used on various types of wagons are given in Table 9.2.

**TABLE 9.2**  
**DETAILS OF SAFETY FITTINGS**

S. N	Description of fittings	Particulars and Mech. Code	Anhydr-ous liquid Ammonia BTAL/BTALN/BTALNM	Liquified petroleum gas BTPGL/BTPGLN	Caustic soda BTCS	BTPN/BTFLN
1.	Safety valves	Nos.	One	Two	One	One
		Drg. NO	MIDLAND A-3200	MIDLAND A-3225	MIDLAND A-1739	WA/TF-87
		Location	Inside dome	Inside dome	Inside dome	Out side dome
		Vapour tight at pressure Kg/cm <sup>2</sup>	22.15 kg/cm <sup>2</sup>	15.85 kg/cm <sup>2</sup>	2.46 kg/cm <sup>2</sup>	01.4 Kg/cm <sup>2</sup>
		Start of discharge pressure	Above 22.15 kg/cm <sup>2</sup>	Above 15.85	Above 2.46 kg/cm <sup>2</sup>	Above 1.4 Kg/cm <sup>2</sup>
2.	Safety vent with frangible disc	Nos.	N/A	N/A	N/A	N/A
		Drg. No.				
		Location				
		Disc not to rupture pressure kg/sq.cm				
		Rupture pressure for disc kg/sq.cm				

**D. Safety valve**

The safety valve is provided to prevent building up of excess pressure inside the barrel. Its fitting on the barrel is either on the diaphragm plate inside the dome or on a separate opening on the barrel. Table 9.2 shows the location, number of safety valves used and their working pressure, etc. for various types of wagons.

**E. Relief valve**

It is a spring loaded valve fitted on the barrel of tanks for corrosive liquids. Its main function is to release built up pressure, if it exceed the working pressure limit. Table 9.2 shows the type of wagons on which these are fitted and their working pressure limit.

**F. Safety vent**

This consists of a frangible disc (lead or any approved material not affected by lading) which ruptures at specified pressure. It is an additional safety fitting to safeguard against the failure of the relief valve. When the built up pressure exceeds the working pressure of the relief valve and the latter fails to function for any reason the frangible disc of this safety vent ruptures to release the pressure.

**G. Compressed air valve**

It is provided on tank wagons from which the contents are unloaded by compressed air. Its main function is to control the rate of discharge by controlling the rate of air admission.

**H. Vapour extractor cock**

Its function is to extract vapour from the tank while filling (Drg.No.WA/TF-2116 & WD-86081-S/60).

**I. Master valve assembly**

It is a gravity discharge valve fitted with a hand wheel in the dome for manual operation.

- J.** In eight wheeler stock, two bottom discharge valves are fitted, one on either side and connected with the master valve through a tee pipe. The main function of the valve is to control the flow of the contents and also to serve as an additional safety stop in case the master valve fails or breaks. The bottom discharge valve openings are also provided with blank flanges to be used with 2mm compressed asbestos fibre jointing material to IS:2712-65 to serve as a further check on accidental leakage of contents.

## 902. PERIODICITY OF OVERHAULING OF TANK WAGON

The periodical overhauling of IRS tank wagons should be carried out in fully equipped mechanical workshops. The periodicity of POH is given below in Table 9.3.

**TABLE 9.3**  
**PERIODICITY OF OVERHAULING**

SN	Type of wagon	For 1 <sup>st</sup> POH	For subsequent POH
01	Tanks for petroleum gas BTAL/BTALN	4 ½ years	4 ½ years
02	Tanks for petroleum gas BTPGL, BTPGLN	4 years	4 years
03	BTPN	6 years	6 years
04	BTCS	4 Years	4 Years
05	BTPH	4 ½ years	4 ½ years

### A. INTERIOR EXAMINATION OF TANK BARREL

No person should be allowed to enter the tank barrel for internal examination/repair unless the barrel is free from Toxic or inflammable fumes. Therefore, before internal inspection of barrel is allowed, it must be steam cleaned/washed with solution of sodium phosphate commercial or soda ash, washed with water or other suitable cleaning agent as prescribed in case of various types of tank barrels.

### B. STEAM CLEANING OF TANK BARRELS

The tank(s) requiring steam cleaning should be placed as near the steam supply line as possible and protected against any movement. The berthing siding should be completely isolated from all other traffic.

Tanks as pressure vessels, tanks for petroleum, other highly inflammable products, vegetable oils, bitumen, coal tar and molasses are cleaned by steam. In case of pressure vessels, it should be ensured that all the gas has been discharged to the atmosphere. After ensuring that the tank barrel is no longer under pressure, the following sequence should be followed:

- i. In case of 4-wheeler tanks, remove the manhole cover together with manhole housing, valves etc. and leave the tank exposed to atmosphere for few hours. This clause is not applicable for BTPN.
- ii. Entry of staff in the tank barrel should be strictly prohibited and signs with suitable legends displayed at a reasonable distances away from the tank(s) to be steam cleaned.
- iii. Insert pipe through man hole and steam interior of barrel for 12 hours. In order that the tank barrel is thoroughly steamed from inside, the stem pipe should be provided with a "T" connection at its lower end and so directed as to blow steam towards both ends.
- iv. Remove condensed steam collected in the tank barrel and keep the barrel exposed to atmosphere for few hours.
- v. Ascertain if the tank barrel is free from gas fumes. This may be done as follows:

**(a) AMMONIA TANK BARREL**

Fill the tank barrel with water and take a specimen of the same in a clean glass bottle since ammonia is readily soluble in water. The specimen of water should be tested for any traces of ammonia with red litmus paper. Any trace of ammonia in water would turn red litmus blue. Another very sensitive method known as Nessler's test may be applied to find out if the specimen of water contains any traces of ammonia. In this test, the reagent used is a solution of potassium mercuric iodide with potassium hydroxide. This reagent gives a brown colour when mixed with the specimen of water containing even a minute trace of ammonia.

If ammonia is detected, empty out the tank barrel and refill with fresh water. This process may be repeated till the tank barrel is free from ammonia traces completely.

**(b) CHLORINE TANK WAGONS**

Fill the tank barrel with water and take a specimen of the same in a clean glass bottle. Since chlorine is readily soluble in water, specimen of water taken out should be tested for any traces of chlorine. Any trace of chlorine in water would have a bleaching effect on coloured litmus paper. If chlorine is present, the tank should be repeatedly emptied and refilled with fresh water till free from chlorine traces completely.

**(c) LPG TANK WAGONS**

A clean bottle filled with fresh water is lowered through the manhole. A string is attached to the bottom of the bottle before lowering. Tilt the bottle at the bottom of the tank to allow its water to flow out and the gas in the tank to take its place. The bottle should be left in this position for about 5 minutes and then withdrawn away from the tank. A lighted match stick should then be brought near the mouth of the bottle or applied to the air or gas inside and bottle. If there is no flame the tank is free from injurious gas. But, in case it gives out a flame, the tank should again be steam cleaned.

After ascertaining that there is no trace of gas in the barrel the tank should be dried out by blowing in hot compressed air before proceeding with inspection and repairs.

Alternatively, Gas should be checked with explosion meter.

**903. CLEANING OF TANKS FOR CORROSIVE LIQUIDS**

**Caustic soda tanks:** These barrels should be washed free of alkalinity with hot water. Freedom from alkalinity can be easily ascertained by litmus test (if red litmus changes to blue, there are still traces of alkalinity). After it is free from alkalinity, water should be drained and barrel dried out before inspection and repairs.

## 904. INSPECTION OF TANK BARRELS

Generally tank barrel defects will be indicated by hydraulic test but it is necessary to inspect the barrel before hydraulic test so as to avoid accidental rupture of corroded barrel plates at the time of hydraulic test. The barrel should be examined by a competent inspector nominated by the CME, who must examine the interior of the barrel and the internal fittings for their general condition and freedom from wasting, wear, tear and damage. Measure barrel thickness by D-meter to ensure extent of corrosion. If the examination indicates that the corrosion/erosion has taken place to such an extent that the barrel is likely to rupture during hydraulic test, first carry out the repairs and then give a hydraulic test.

## 905. TESTING OF BARREL

- A. Ensure that all filling lines with low pressure and other apparatuses, which should not be subjected to the test pressure, are disconnected.
- B. The tank barrel and manhole orifice should then be completely filled with water at a temperature which must not exceed 38 Deg.C (100 Deg.F) during test. The barrel should be vented to prevent formation of air pockets while it is being filled. Before applying pressure, the equipment should be inspected to see that it is tight. The tank barrel should be tested by using a power driven hydraulic pump which should enable a steady increase of pressure in the tank barrel. Test pressure should be maintained for a sufficient length of time to permit a thorough examination of the barrel for any leaks.

For the purpose of this test, connection is to be made through a dummy flange with pressure gauge attached, fitted on the safety valve seating. The filling, discharge and gas valve should be tested in position on the tank in following two ways:

- a) With valves closed and outlet cap off, and
  - b) With valves open and outlet cap in position.
- C. In case of any sign of leakage that may be evident from the drop in pressure under hydraulic test, the pressure should be reduced by 20%. The lagging and insulation is removed for locating leaks. The welded seams of the tank barrel should be given a thorough hammer test by striking the plates on both sides adjacent to the weld. The plate should be struck at intervals of about 6" for the whole length of all main welded seams.
  - D. The hammer used for the above test should be of a material softer than the barrel plate and its edges so rounded as to prevent denting of the barrel plates. The weight of the hammer should not exceed 5 Kg.
  - E. The pressure should then be raised to the full test pressure and maintained for a sufficient length of time, but not less than 30 minutes. Inspect all seams and connection.
  - F. The tank barrel should remain secured to the underframe during this test.

**906. BARREL TEST PRESSURE**

The testing pressures for different types of wagons are given in the following table:

Description	Mech. Code	Hydraulic test pressure
Ammonia tank	BTAL, BTALN	33.25 Kg/ cm <sup>2</sup>
LPG tank	BTPGL, BTPGLN	22.1 Kg/ cm <sup>2</sup>

**907. TESTING OF TANKS USED FOR CORROSIVE LIQUIDS**

The procedure for testing of caustic soda tanks is the same as that given for tanks as pressure vessels above except that their testing pressure would be 4.5 Kg/cm<sup>2</sup>.

**908. TESTING OF TANK WAGONS USED FOR PETROL AND MIDDLE DISTILLATES OF PETROLEUM AND VEGETABLE OIL**

The following procedure should be followed for hydraulic test of petrol tanks:

- A) Remove the safety valve from its seating and fill the tank completely with water. Provide connections with the hydraulic pump through the safety valve opening. Close the manhole cover and fully tighten it. It should be ensured that the bottom discharge valve is properly closed before filling the barrel with water. The pressure should be increased gradually by means of a hydraulic pump provided with a pressure gauge. Close the control cock as soon as the hydraulic pressure reaches 2.8 Kg/ cm<sup>2</sup> for BTPN wagons. Watch the pressure for a minimum period of 30 minutes.
- B) In case of leakage (which will be evident from the drop in pressure under hydraulic test), the joints should be checked first and made tight. Thereafter, the well seems of the tank barrel should be examined thoroughly by applying soap solution, which will show up the crack or other source of leakage.

**909. REPAIRS TO TANK BARRELS BY WELDING****A. Pressure vessels**

Pressure vessels requiring repairs should be inspected by a competent authority approved by Chief Controller of Explosives. A workshop undertaking such repairs must be properly equipped for the same and facilities for radiographic examination of the repaired joints must be available. The detailed procedure for repairs of pressure vessels is given in Appendix – IV.

**B. Tanks for transport of corrosive liquids**

- i. Tanks used for transport of corrosive liquids suffer most, commonly from pitting and also have a tendency to develop cracks. Pits when not deep enough to affect the strength of the parent plate may be chipped to sound metal welded and then ground flush to the original

thickness of the plate. When pits are in a close group or in one straight line and are deep enough to affect the strength of the plate, the affected area should be cut out and replaced with a let in patch.

- ii. Cracks should be fully explored to ascertain their extent. The crack may be on surface or in full depth of the thickness. If possible, a portable magnetic crack detector should be used. Such detectors are manufactured in the country and are a very useful piece of equipment for every railway workshop. In absence of crack detector, dye penetration test shall be performed to ascertain extent of crack. A 12mm dia hole should be drilled at the ends of the crack and the full length of the crack should then be carefully chipped and C grooved for welding. Removal of all paint, grease, oil, dirt etc. by flame heating and brushing is essential both for the purpose of proper inspection and to prevent contamination of the welded joint. Perform DP test and then do welding.
- iii. After completion of welding from one side, the other side of the crack should be grooved, cleaned and welded. It is preferable if the welding is done from the inside of the barrel and is in the down hand/horizontal position. Flush ground the welded position and perform DP test along the weld.
- iv. If a crack occurs in an area where the plate is wasted and of inadequate strength, the defective portion should be cut out and replaced with a let in patch. It must be ensured that the let in patch is of the same material and thickness as the parent metal. Corners of patches should be rounded to a minimum radius of 25mm and edges must be carefully prepared to obtain a V butt weld. Weld deposits should be smoothed flush with the parent metal. Perform DP test and radiography of barrel plate.

#### **C. Tanks for petrol, middle distillates of petroleum, vegetable oil etc.**

The repair procedure will generally be same as described above.

#### **D. Welding procedure and technique**

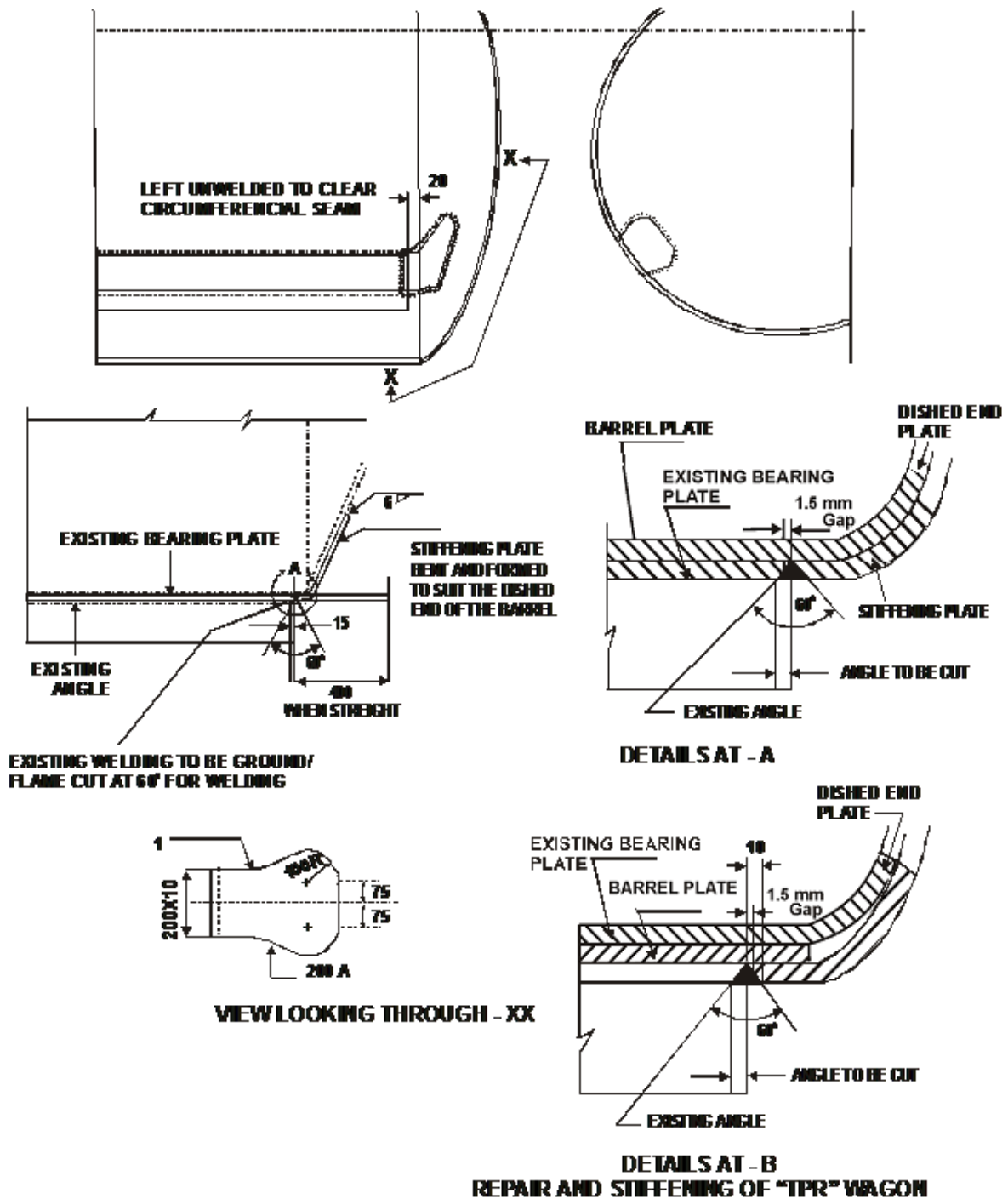
- i. Only approved brands and grades of electrodes should be used. Lists of such approved brands and grades are published by RDSO every year and these should be available in all workshops and repair depots for reference and guidance.
- ii. Welding should be as possible done in the down hand position. Welding current (also polarity if direct current is used) should be set as recommended by the electrode manufacturer.
- iii. Transverse speed of the electrodes should be controlled to obtain proper fusion of the parent metal.
- iv. After every interruption of the arc, welding should be restarted ahead of the previous deposit and then moved back to fill the crater before proceeding forward again.
- v. Care should be taken to remove slag before depositing successive beads.



**E. Welding of stiffening plate.**

Weld reinforcement should be made flush with the parent metal of the tank barrel for welding a stiffening plate.

First, tack weld the stiffening plate in the position as below. Stiffening plate to be fitted from outside only. They should be welded with the angle in the case of old design wagons having the bearing plate inside. In case of new designs having both angle and bearing plate outside, weld with the existing bearing plate. The welding should be completed as shown in Fig. 9.1.



**Fig. 9.1 : TANK WAGON WITH BEARING PLATE OUTSIDE**

## **910. REPAIRS AND TESTING OF TANK BARREL MOUNTING FITTINGS.**

### **A. Fittings of pressure vessels**

#### **a) Safety valve**

The safety valve should be given a pneumatic test. It must be vapour tight against leakage at pressures indicated in Table 9.2.

The safety valve adjustment should not be interfered with unless repairs to the valve become necessary or the valve operates incorrectly. In such cases, it must be repaired, correctly adjusted and re-tested at the pressure specified.

- b) Packing and seals must be particularly checked for leaks, and those found defective or damaged, perished, should be changed. The packing should be of correct material and size/shape.

Since deteriorated seals and dirt on the seals are the most frequent cause of leakage, the seals should be given careful attention. Changing of resilient seals of liquified petroleum gas tank wagons, when the vessel is under pressure within 10 pounds of the operating pressure of the valves, should not be attempted.

#### **c) Other fittings of pressure vessels:**

- i. Apart from the safety valve, each type of mounted pressure vessel has its own special fittings. The fittings are specific for each type of vessel and details regarding their examination and maintenance are contained in instructions pamphlets published by the RDSO for the respective wagons.
- ii. Items to be particularly checked for defective, damaged or perished packing. "O" ring, "V" ring and lead seals. Asbestos packing or rubber packing is commonly used depending upon the type of vessels and commodity carried. V rings are pressure seals, which expand on application of pressure to remain leak proof.
- iii. The various valves and fittings of these vessels are usually designed to give long periods of trouble free service and should not ordinarily require any maintenance other than cleaning. However, if a fitting become defective, it would be desirable to consult the manufacturer. Most of these valves and fittings are specialized pieces of equipment, made of special materials. Substitution by components made of incorrect materials or to wrong tolerances could have undesirable repercussions.
- iv. The main fittings are two liquid education valves, a vapour education valve, a safety valve, a slip tube for determining liquid level, a pressure gauge, a thermometer well and excess flow valves which control the rate of flow through the three education valves.

**B. PRESSURE GAUGE**

In view of the possibility of pilferage/damage, the pressure gauge should be fitted only when required at the time of filling or discharging, or when the pressure is to be checked enroute. It should be removed before releasing the tank wagon. The necessary valve and fittings for attachment of the pressure gauge are provided on the manhole cover plate.

**911. FITTINGS OF TANKS FOR CORROSIVE LIQUIDS**

- A) Pressure relief valve/safety valve: These valves should be given a pneumatic test at the pressures indicated in the table 9.2.
- B) Safety vent with frangible disc: The safety vent should be provided with rubber lining and closed with a frangible disc which should rupture at a pressure not exceeding the predetermined value. The ruptured frangible disc indicates that excessive pressures have been built up in the tank wagon and may be the first sign of malfunctioning of the safety valve. The cause needs to be investigated and removed. A ruptured frangible disc should be replaced by a new frangible disc, conforming to the required specification.
- C) Globe valves/compressed air valves/washout valves: All these valves should be tested on a bench by applying hydraulic pressure by means of a pump and it should be ensured that they are leak proof at the pressures of individual wagons mentioned under "Testing of the Barrel" in para 1008 above. Leaky valves should be attended for defects before fitting body on the tank.

**912. FITTINGS ON TANK WAGONS OF PETROL, OTHER INFLAMMABLE PRODUCTS, VEGETABLE OIL ETC.**

- A) **Safety valve** : These valves are provided on petrol tank wagons. The safety valves should be subjected to pneumatic test after repairs/POH at the pressure given.
- B) **Master valve**: Wherever repairs to the master valve and its seating are undertaken, after filling the valve should be tested in position under air pressure of 0.35 to 0.56 Kg/ cm<sup>2</sup> (5 to 8 psi), the tank barrel being filled with water to a minimum height of 150 cms. The hydraulic test should be carried out keeping the bottom discharge valve and blank flange open.
- C) **Bottom discharge valve** : The bottom charge valve should also be tested in position under air pressure of 0.35 to 0.56 Kg/ cm<sup>2</sup> (5 to 8 psi) after filling the tank barrel with water to a minimum height of 150 cm. Master valve should remain open during this test. This test to be done after satisfactory testing of the master valve.
- D) **Blank flange** : The blank flange should be tested in the same manner as the master valve and bottom discharge valve after ensuring that a gasket of specified material has been fitted underneath.

### **913. TEST REPORTS AND RECORDS OF INSPECTION**

Re-tests of all tanks, safety valves and rubber lining must be certified by the official making the tests and records maintained in the office of the CME. Certification must show railway initial, number of tank wagon, pressure to which tested, date and place of test, etc. A copy of the certificate may be submitted to the party owning the tank wagon in the case of private or dual owned tank wagons.

The testing authority must maintain detailed records of the tests carried out on each individual tank wagon.

A special report must be submitted to the CME concerned in every case where the maximum permissible working pressure is reduced or the examination shows that the tank can not continue to be used with safety unless certain repairs are carried out immediately or within a specified time. Such a tank wagon must not be commissioned in service till it is certified fit for use after repairs and re-testing under specified pressure by the testing authority.

The testing authority competent to test the barrel, safety valve and rubber lining under the above clause is to be nominated by the CME.

### **914. IMPORTANT MODIFICATIONS**

The important modifications to be carried out in workshops and depots are given in Table 9.4.

### **915. PAINTING AND LETTERING**

Full schedule of painting and lettering following as per marking diagrams issued by RDSO for each such type of wagon. The test particulars must be marked at the prescribed places on the tank wagon. In case of tanks used for acids the external surface of the tank barrels should be painted with an acid-resistant paint to prevent external corrosion.

Specification of the paint should be generally as per G-72/Marking diagram. While using these paints care should be taken to prepare the surface properly so that all rust loosely adherent scale and dirt are removed by means of metal scraper suitable hammer and wire brush. Grease oil etc if present should also be removed with white spirit or other suitable solvent. In case of tanks already used for carrying acid care should be taken to wash down the surface with water to remove all traces of acid and to ensure that the surface is dry before application of paint.

**TABLE 9.4****LIST OF IMPORTANT MODIFICATIONS IN BTPN TANK WAGON**

Sr .N	ITEM DESCRIPTION	Purpose	Drg. No.	RDSO's REF.	TO BE DONE IN			
					SICK LINE	ROH	POH	NEW BUILT
1.	Sealing Gasket ring in the main hole & filling pipe cover	To remove the problem of sealing ring comes out from the groove	WD-86081-S/ 60 & WD-86081-S/ 61	MW/BTPN dtd. 13/16.06.2003	Yes	Yes	Yes	Yes
2.	Pin for Master valve spindle & valve operating screw	Length of the pin increased to avoid the breakage of pin	WD-86081-S/ 65	MW/BTPN dtd. 10.10.2003	No	Yes	Yes	Yes
3.	Valve spindle nut bottom	Material valve spindle nut bottom changed from IS: 1458 (bronze) to stainless steel IS: 660307r18Ni9 to avoid the nut get sheared off	WD-86081-S/ 66	MW/BTPN dtd. 10/14.10.2003	No	Yes	Yes	Yes
4.	Flanges cover design of bottom discharge pipe	Thickness of cover plate reduced to 3.15 mm from 8.0 mm & embossed at the centre for stiffness.	WD-86081-S/ 65	MW/BTPN Dt. 9/14.12.2004	Yes	Yes	Yes	Yes
5.	Filling pipe	A magnet at the bottom of filling pipe provided to arrest the foreign item such as nut, bolt & locking wire etc. to avoid the damage of the seat of master valve	WD-86081-S/ 61	MW/BTPN Dt. 29/12 /6.01 2004.	No	Yes	Yes	Yes
6.	Provision of rubber piece on the barrel	To avoid the damage of dome cover during opening of cover.	WD-86081-S/ 58	MW/BTPN Dt. 22.02.2005	Yes	Yes	Yes	Yes
7.	Stiffener plate	Additional stiffener plates provided on the top of centre sill and above the back portion of CBC to avoid the lifting of CBC and hitting of barrel.	WD-86081-S/ 53 & WD-86081-S/ 54	MW/BTPN Dt. 14/15.7.2005.	Yes	Yes	Yes	Yes
8.	Manhole joining	Location of holes on the right side portion of manhole joining changed as correctly suggested by S. Rly.	WD-86081-S/ 61	MW/BTPN Dt. 2.04.2004	No.	Yes	Yes	Yes

Sr .N	ITEM DESCRIPTION	Purpose	Drg. No.	RDSO's REF.	TO BE DONE IN			
					SICK LINE	ROH	POH	NEW BUILT
9.	Bolster bottom flange	Bolster bottom flange profile modified and stiffener added to remove the possibility of centre sill crack as reported by JHS Workshop	WD-86081-S/ 53, WD-86081-S/ 55 & WD-86081-S/ 66	MW/BTPN dtd 07.07.2009	No.	Yes	Yes	Yes
10	Bogie mounted brake system	To develop the new braking system with better performance and lesser rigging parts	New Drawing No. WD-09050-S/00 to 11 (Twelve Drgs.) prepared for BMBS, other drawings will be as per WD-09050-S/00(Index).		No.	No.	No.	Yes

## 916. EXAMINATION AND REPAIR OF TANK WAGONS BY C&W SUPERVISOR AT SICK LINE & BASE DEPOT

- A) Any repairs to tank barrels should be done only at nominated sick lines where facilities for steam cleaning are available. After repairs, the barrels and valves must be tested to ensure that there is no leak. Safety valves must not be permitted with any nut or bolt deficient from sickline. The tank wagon discharge valves blank flange and manhole covers should be secured with full complement of bolts and nuts whenever the tank wagons are empty or taken out of sickline. Whenever tank wagons containing petrol or other inflammable fluids are examined, only specified safety torches (battery torches) should be used for this purpose.
- B) Before any repairs are commenced on such stock, due precautions must be taken to remove all such petroleum and other inflammable fluids as required under IRCA red tariff and special instructions issued by the railway/railway board from time to time. These precautions must be observed on empty tank wagons also and no staff should be allowed to enter the tank or to bring naked light or matches near it till the tank has been steam cleaned and tested free of vapour.

The following checks should be carried out by train examining staff before a tank wagon is certified fit for loading:

- a. **Master valve** : Leakage of master valve should be checked while keeping the bottom discharged valve open.
- b. **Bottom discharge valve** : Proper functioning and fluid tightness of the bottom discharge valve should be ensured.
- c. **Blank flange** : The blank flange of the correct thickness made out of steel plate and with a gasket of proper material between the blank flange and bottom discharge valve flange should be tightened by six bolts and nuts.
- d. **Tank barrel** : Tanks with cracks on barrels should be marked sick.
- e. **Leaky tank barrels** : The leakage of tank barrels may be caused due to one or more of the following reasons:
  - i. Mechanical injury to the valve face and/or valve seat as a result of foreign material, particularly nuts and bolts finding their way inside the tank wagon.
  - ii. Valve seats not properly secured to the stool by proper interference fits.
  - iii. Mal functioning of master valve.

## 917. PRECAUTION WITH LEAKY TANK WAGONS

### A. BTAL, BTALN tank wagons

Ammonia gases are poisonous gases and have a characteristic pungent odour, which gives warning of their presence in the atmosphere before dangerous concentrations are attained. In the case of ammonia, if sufficient concentration of the gas is present in the atmosphere, it will irritate the eyes and the respiratory system. As such, in the event of leakage, all present in the vicinity should be warned to keep on the wind ward side of the leak.

**B. BTPGL & BTPGLN tank wagon**

Action in any particular case will depend upon existing conditions, and good judgement will be necessary to avoid disastrous fires on one hand and useless sacrifice of valuable property on the other hand:

- a. When a tank wagon is leaking, all flames or fires near it should be extinguished or removed. No smoking should be allowed. Spectators should be kept away. Only battery operated torches or incandescent electric lights with gas proof sockets should be used.
- b. Oil lanterns or signal lamps necessarily used for signalling must be kept far away and at as high an elevation as can be obtained from the tank and on the side from which wind is blowing. The vapour will go with the wind, not against it. The ash pan and fire boxes of steam locomotive are sources of danger especially when wind is blowing across the leaking tank towards them. The locomotives be moved away from the site and ash pit fires be extinguished with water.
- c. The leaky tank wagon should be removed as quickly as possible to an open area where the escaping gas will be less hazardous.
- d. Earth should be spread over any surface on which the LPG has leaked out in liquid form.
- e. A leaky tank, which has been emptied, should under no circumstances be sent to the loading point and should be suitably stenciled as such. A leaky tank wagon must only be dealt with in a fully equipped mechanical workshop.
- f. Recommended procedures to stop leaks in dome fittings:
  - i. The liquid outlet valves face each end of the tank wagon, while the vapour outlet valves face the sides of the wagon. If there is leakage around the valve hold down bolts, tighten the bolts until the leakage stops. If leakage persists, isolate the tank wagon and notify the oil company concerned.
  - ii. If there is any indication of leakage around safety valve, which is in the centre of the dome, it should first be checked whether the valve is merely performing its function, i.e., relieving excess pressure. However, if considerable flow of gas is evident, isolate the tank wagon and notify the oil company concerned.
  - iii. If there is leakage from the outlet of the valve, turn the valve handle by hand, if it does not stop leaking, the seat is defective. Do not try to use a wrench but insert and tighten the plug attached by a chain to the valve.
  - iv. If there is any leakage out of the thermometer well, the only thing that can be done is to tighten the plug. If the leak cannot be stopped, by tightening, isolate the wagon and notify the oil company. **DO NOT TAKE THE PLUG OUT FOR LAPPING OF THE THREAD.** The thermometer well is, in fact, a part of the shell of the tank, and if there is any evidence of leakage from the thermometer well, a bad situation is indicated. If the plug is removed when leakage is present, liquid will probably be discharged with a consequent extreme hazard.
  - v. A high percentage of any leaks that might occur will be in the gauging and sampling devices. The sampling valve is a part of a fixed line to the bottom of the tank. The valve on the gauging device



(slip tube) must be used in gauging the volume of the liquid in the tank wagon. It is open while moving the gauge down to find the liquid level. Once the liquid level is found, the valve should be closed. In both cases, a turn of the shut off valve handle will probably stop any leakage that might be occurring through the valve. However, on the slip tube, which is moved up and down to determine the liquid level, there is a packing gland, which is subject to wear. If the leak is occurring through this packing gland, tighten the packing nut until the leak stops.

- vi. The Junior Engineer (C&W) staff must be most careful that liquefied petroleum gas does not get on their skin. The effect is substantially the same as when dry ice comes in contact with the skin viz. freezing. The white fog of its discharge can distinguish liquefied petroleum gas while liquid can only be distinguished by careful viewing. In many cases, soapy water must be used to locate liquid leaks because they are not readily visible.

### **C. All other types of tanks**

No leaky tank wagon should be allowed in service and such tank wagons should be attended in properly equipped sick line and/or shops.

### **D Additional precautions in cases of heavy leakage/spillage**

- In case of heavy leakage which can not be stopped by closing of valves, evaluate leaks and determine repair materials and techniques to be used. Contact nearest Rly. Station and oil installation.
- The station master shall send telegraphic/telephonic advice to nearest Train Examiner & control and other authorities
- Ensure that there are no ignition sources including mobile phone nearby and passers by do not smoke or carry open flame.
- Isolate the heavily leaky wagons and keep as far away from the train as possible.
- During isolation, take care to avoid any hammering, sparking.
- Have 'Dangerous' 'not be loose shunted' Labels affixed on both sides of such wagons.
- Carden off the area.

## **918. PRECAUTIONS TO BE TAKEN AT LOADING AND UNLOADING POINTS (TANKS AS PRESSURE VESSELS)**

- i. Ensure that the tank is loaded/unloaded under supervision of a responsible and competent person and all precautions taken by him to see that the persons engaged in the filling/discharging operations are properly protected against the poisonous gas contaminated atmosphere. A list of precautionary measures to be taken by the staff must be exhibited at a conspicuous place near the installation. The loading/unloading connections must be securely attached to the pipe line before valves are opened.

- ii. Ensure that the tank to be loaded/unloaded is placed in position, preferably under shade, and secured properly against any movement. The handbrakes must be put on and hand brake lever secured in that position.
- iii. Shunting of any kind of the tank under loading/unloading must be strictly prohibited.
- iv. Ensure that points leading to loading/unloading line on which the tank is to be loaded/unloaded are set and pad locked so as to isolate the line on which loading/unloading is to be done. If loading/unloading is to be done at one end of a long siding, it must be protected properly by a scotch block or other authorized device so as to prevent any wagon dashing against the tank wagon. It must also be ensured that shunting is not permitted on the same line when loading/unloading is being done.
- v. Ensure that signs are exhibited at a suitable distance away from the tanks on the approach end or both ends as applicable.
- vi. Ensure that the tank is filled by connections to the liquid valves, which have dip pipes to the bottom of the tank. The other gas valve is connected to the absorption system of the chlorine plant or Ammonia plant. In the case of LPG tanks, two liquid valves are provided for loading/unloading of the tank. The rate of flow of LPG liquid becomes too great in case only one liquid line is provided and this may result in the excess flow valve (provided inside the pipes below the diaphragm plate) closing off. Use of only one valve may result in closing down of excess flow valve repeatedly.
- vii. The tank should not be loaded beyond its marked capacity under any circumstances.
- viii. Tank wagon(s) must not be allowed to stand with loading/unloading connections attached after loading/unloading is completed.
- ix. Throughout the entire period of transfer operations or while the tanks connected to loading/unloading devices, the tank(s) must be continuously attended to by the operator.
- x. If it is necessary to discontinue transfer operations for any reasons, all loading/unloading connections must be tightly closed and closure of all other concerned components strictly ensured.
- xi. On completion of filling operation, the valves should be properly closed and dome cover sealed. The caution signs should then be removed and padlocks on the points opened to enable the tank(s) to be taken out for attaching to trains.
- xii. The loading of pressure gas tank wagons must be carried out by using a gas compressor i.e. the compressor will be connected to the gas valve on the tank. The liquid valve on the tank will be connected to the storage tank. By ensuring that the pressure in the tank barrel is about 10 lbs/sq.in (gauge) above the pressure in the storage tank, the liquid gas will discharge itself. To avoid reverse siphoning of the liquid gas into the tank barrel, the above pressure must be maintained inside the barrel till such time the whole contents are discharged.
- xiii. While discharging, the pressure inside the tank barrel should be maintained steady so as to avoid any chance of sudden evaporation and consequent chilling of the barrel plates.

- xiv. When all the liquid gas has been transferred, which will be indicated by the level ceasing to rise in the storage tank, the liquid valve on the tank must be closed.
- xv. All tools and implements used in connection with transfer operations must be kept free from oil, grease, dirt and grit.
- xvi. Seals and other substances must not be thrown into the tank. Care must also be taken to avoid spilling of the contents over the tank.

### **919. LOADING AND UNLOADING CORROSIVE LIQUIDS**

- i. Only Phosphoric acid and caustic soda 8-wheeler wagon exist in Railways. Caustic soda lye (liquor) having specific gravity of 1.51 at 15<sup>0</sup>C or a concentration of not less than 48% and containing not more than 3% of any chloride and no free chlorine, is loaded in the caustic soda tanks.
- ii. Before loading, it should be ensured that the tank barrel and washout valve is free from any leaks and the dome cover fits airtight. A leaky tank wagon should not be allowed to run on line and it should be suitably marked for repairs after unloading. Dome fittings should be inspected for leaks and other defects before unloading to avoid acid spillage or spraying.
- iii. An air space of not less than 5% of the capacity of the tank should be left. When higher concentrations are filled, it should be ensured that tank wagon is not overloaded beyond its carrying capacity in tonnes.
- iv. All empty tank wagons should be securely closed airtight as sulphuric acid is self-diluting and absorb moisture from atmosphere. Dilute sulphuric acid is highly corrosive to mild steel.
- v. During the loading and unloading operations, caution signs must be exhibited at a suitable distance away from the tank on the approaches at both ends.
- vi. Smoking or bringing a naked flame or lamp near sulphuric acid wagons is strictly prohibited. An incandescent electric light with gas proof socket should be used.
- vii. At the time of loading/unloading, the tank wagons should be protected by means of scotch blocks or other suitable devices to prevent any risk of damage due to inadvertent shunting.
- viii. Steel spanners/tools should not be used as they may cause sparks on striking, Brass tools may be used.
- ix. All spillage of acid should first be neutralized by means of hydrated lime and washed down the drain with an adequate supply of water.
- x. The tank wagon has a top discharge arrangement. For loading the tank it should be connected to an air compressor through the globe valve and it must be ensured that the pressure in the tank does not rise above 30 psi. The discharge pipe should be connected to the designated line after removal of the blank by means of a suitable flange after inserting a rubber gasket/lead lining. The gasket/lead lining prevents spillage of acid on the tank barrel.
- xi. The filling in of the tank wagon is also effected through the discharge pipe by connecting it to the consignee's acid supply pipeline by means of a suitable flange after inserting a rubber gasket/lead lining. During the filling in operation, the globe valve/air compression valve should be in open position to permit exit of air from the tank.

## 920. LOADING AND UNLOADING OF TANK WAGONS

- i. Adequate supervision of filling and emptying of wagons is necessary to ensure that this is done in an authorized manner only.
- ii. The filling should be done from the filling and discharge pipe. This pipe is provided with a rubber lined flange. A corresponding flange should make the connection to the acid supply line after inserting a rubber gasket between the filling flange and the supply flange. The gasket prevents spillage of acid on the tank barrel and would also prevent damage to the rubber lining on the filling/delivery flange.
- iii. In order to give vent to the air inside the tank barrel, the air flange should be removed for the filling operation.
- iv. The decanting should be done after connecting the delivery pipe to the discharge flange. Connecting with the help of a suitable flange using a rubber gasket should do this.
- v. The air pipe flange should be removed and a pneumatic line should be connected to the air pipe, by means of a suitable flange after inserting a rubber gasket.
- vi. The pneumatic pipeline should be connected to a pneumatic system wherein the pressure in the line cannot exceed  $1.75 \text{ Kg/cm}^2$  (25 psi). This is done to prevent damage to the tank barrel.
- vii. After the tanks have been unloaded, they should be filled with clean water at a temperature not exceeding  $38^{\circ} \text{ C}$  ( $100^{\circ} \text{ F}$ ). This is done to prevent deterioration of the rubber lining as the rubber decomposes in presence of air.
- viii. All spillage of acid should be washed down the drain with an adequate supply of water. If the spillage is excessive, the acid should first be neutralized by means of hydrated lime.

## 921. PRECAUTIONS FOR TANKS FOR PETROLEUM AND OTHER INFLAMMABLE PRODUCTS

### A. At loading points

- i. Ensure that all tank fittings are in good working condition.
- ii. Ensure that tank fittings are provided with requisite anti-pilferage devices.
- iii. Ensure that the safety valve is intact and properly sealed.
- iv. Ensure that the master valve is fluid tight.
- v. Ensure that the bottom discharge valve is fully closed and fitted with a blank flange and gasket before commencement.
- vi. Ensure that the vapour extractor cock and vent plug are open before commencement of loading.
- vii. Ensure that loading is done through the filling pipe only.
- viii. Ensure that recommended air space as specified for the particular petroleum product is provided and that payload does not exceed the permissible limit.
- ix. Remember to close the vapour extractor cock after loading.
- x. Remember to fit the cap on the vapour extractor cock after loading.

- xi. Remember to fit the cap on the filling pipe after loading.
- xii. Ensure closure of the vent plug cock after loading.
- xiii. Provide proper sealing when dome cover eye bolt nuts are tightened.
- xiv. Make sure that the dome cover is closed after loading.

**B. At unloading points**

- i. Close the master valve after unloading.
- ii. Close the bottom discharge valve after unloading.
- iii. Fit the dummy flange with gasket and all its bolts back in position after unloading.
- iv. Close the dome cover after unloading.
- v. Tighten eye bolt nuts of dome cover after unloading.
- vi. Do not allow rough, hump or loose shunting.
- vii. Do not allow unauthorized persons to operate valves.
- viii. Do not allow any person to enter the tank barrel for internal examination/repairs unless the barrel has been steam cleaned.
- ix. Do not undertake repair of the tank barrel by welding unless it is properly steam cleaned.
- x. Do not start welding repairs on a tank wagon fitted with roller bearings unless the barrel is properly earth and roller bearings are short circuited.
- xi. Do not allow tank wagon to move from loading/unloading points unless the tank fittings are properly refitted and dome cover closed.

**C. Action to be taken in case of fire:**

- Eliminate source of ignition.
- Organize dispersal of vapour.
- Cut-off source of leakage to extinguish fire.
- Allow the fire to continue under controlled conditions, till all the fuel is burnt.
- Use water spray to cool equipment on fire and adjacent equipments.
- Not to extinguish flame at leak to avoid uncontrolled explosive re ignition.
- Inform all concerned depending upon gravity of fire.
- Contact LPG bottling plants for assistance in case of emergency

**922. MAINTENANCE AND REPAIR IN SICK LINE**

- A) No person should be allowed to enter the tank barrel for internal examination/repair unless the barrel is free from noxious or inflammable fumes. Therefore, before internal inspection of barrel is allowed, it must be steam cleaned/washed with solution of sodium phosphate commercial or soda ash and washed with water or other suitable cleaning agent as prescribed in case of various types of tank barrels.
- B) Before any repairs are commenced on such stock, due precautions must be taken to remove all such petroleum and other inflammable fluids as required under IRCA red tariff and special instructions issued by the Railway/Railway Board from time to time. These precautions must be observed on empty tank wagons also and no staff should be allowed to enter the tank or to bring naked light or matches near it till the tank has been steam cleaned and tested free of vapour.
- C) Any repairs to tank barrels should be done only at nominated sick lines where facilities for steam cleaning are available. After repairs, the barrels and valves must be tested for leak. Safety valves must not be permitted with any deficient nut or bolt from sickline.
- D) The tank wagon discharge valves blank flange and manhole covers should be secured with full complement of bolts and nuts when the tank wagons are released from sickline.
- E) Whenever tank wagons containing petrol or other inflammable fluids are examined, only specified safety torches (battery torches) must be used for this purpose.
- F) In addition to routine attention to underframe, suspension, running gear, draw gear, buffing gear and braking gear, the following examinations and repairs to be done in sickline :-
  - i) Examination of tank barrels.
  - ii) Testing of discharge valves and barrels to ensure that there is no leak.
  - iii) Adjustment and examination of security fittings of safety valves
  - iv) Examination of tank barrel insulation where provided.
  - v) Examination of dome equipment
  - vi) Examination of barrel, cradles and fastening arrangements
- G) The checks as mentioned in para 917 B must be carried out by train examining staff before a tank wagon is certified fit for loading.
- H) Testing of barrel is to be done as given in para 905.
- I) Procedure for repairs of tank barrel to be followed as given in para 909.
- J) The important modifications to be carried out in depots are given in Table 9.4.
- K) The painting and lettering to be done as given in para 916.

### 923. MAINTENANCE AND REPAIR IN WORKSHOP DURING POH

The periodical overhauling of IRS tank wagons should be carried out in fully equipped mechanical workshops. The periodicity of POH (refer IRCA Part III Rule 2.4.3) is given in Table 9.3. For various type of tank wagons, detailed maintenance procedure is given in RDSO publications listed in Table 9.5. The detailed procedure for repair of tank wagon pressure vessels is also described in Appendix-IV.

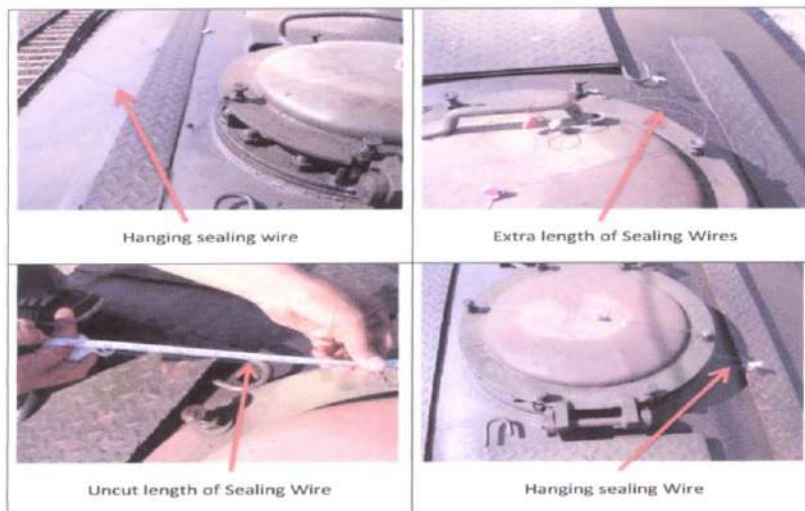
### 924. Instruction for Maintenance and Operation of Bogie Petrol Tank Wagon Type BTPN.

(Amendment No. 4 of July, 2012 applicable to RDSO technical Pamphlet No. G-90 of November, 1991)

#### *To prevent possible fire risks due to electrical tracking through OHE-*

1. Oil companies/ loading parties shall switch over to non-metallic sealing wires for dome covers progressively.
2. Till such time the switchover to non-metallic sealing wires does not materialize, the Oil companies/ loading parties shall ensure that the metallic sealing wires are wound taut and the loose/ uncut length of the sealing wires does not project more than 1inch (25 mm) vertically from the centre of the hole provided in eye bolts for sealing. Loose winding of sealing wires all around the Dome Cover is strictly prohibited.
3. Used sealing wires shall be removed completely from the Dome Cover and shall not be left on the wagon Body/ Barrel.

Appendix 1



Pictures of Extra Length Sealing Wire used on Dome Cover of BTPN Wagons

## **925. Prevention of fire risks due to proximity of sealing wires with contact wire of OHE**

1. Correction slip 7 of IRSOD 2004 espouses a minimum electrical clearance of 270 mm of Rolling Stock from the contact wire.
2. Reports from zonal railways have been received as regards adhoc metallic sealing arrangement being adopted by loading parties at loading points.
  - a) It is reported that long metallic wires are wound around various eyebolts (With holes for sealing wires) of the dome cover, sometimes crossing the dome cover diagonally.
  - b) Similarly, it is also reported that at unloading points, the metallic lead seals are left hanging at the dome cover after the unloading operation.
  - c) This leads to long uncut and undesirable lengths of metallic sealing wires hanging from the dome covers, which during run, may breach the minimum electrical clearance requirements IRSOD.
  - d) Some representative pictures are enclosed as appendix-I to this annexure.
3. The design of the eye bolts as per ISO drawing No. WD-86081-S-60 and WD-86081-S-61 is such that sealing in even one bolt is enough to ensure the theft protection as it shall not be possible to open the dome cover without damaging the seal. At max, sealing on two adjacent bolts, individually, shall suffice to ensure anti theft protection.
4. The practice of winding the sealing wires all around the dome cover eye bolts, in a loose condition, is not correct. Being a potential cause of fire due to electrical tracking, the same should be discontinued.
5. While ensuring the sealing on one/ two adjacent bolts, it should be ensured that the uncut length of the metallic sealing wire in vertically taut condition does not project more than one inch from the centre of the hole provided in the eyebolt for sealing. This shall ensure adequate electrical clearance from the OHE.
6. Similarly, at unloading points, the used sealing wires must be removed from the wagon dome covers.
7. Railways may engage with oil loading parties/ oil companies under their jurisdiction to progressively switch over to non metallic seals, so that chances of electrical tracking (due to human failures) and consequential fires are reduced.
8. While on the subject, it is imperative to ensure the presence of gasket to RDSO drawing No. W/TF-2169 on the dome cover, as the same provides a sealing protection to possibility of product vapours emanating from the sampling pipes, filling pipes and vapour extractor cocks.



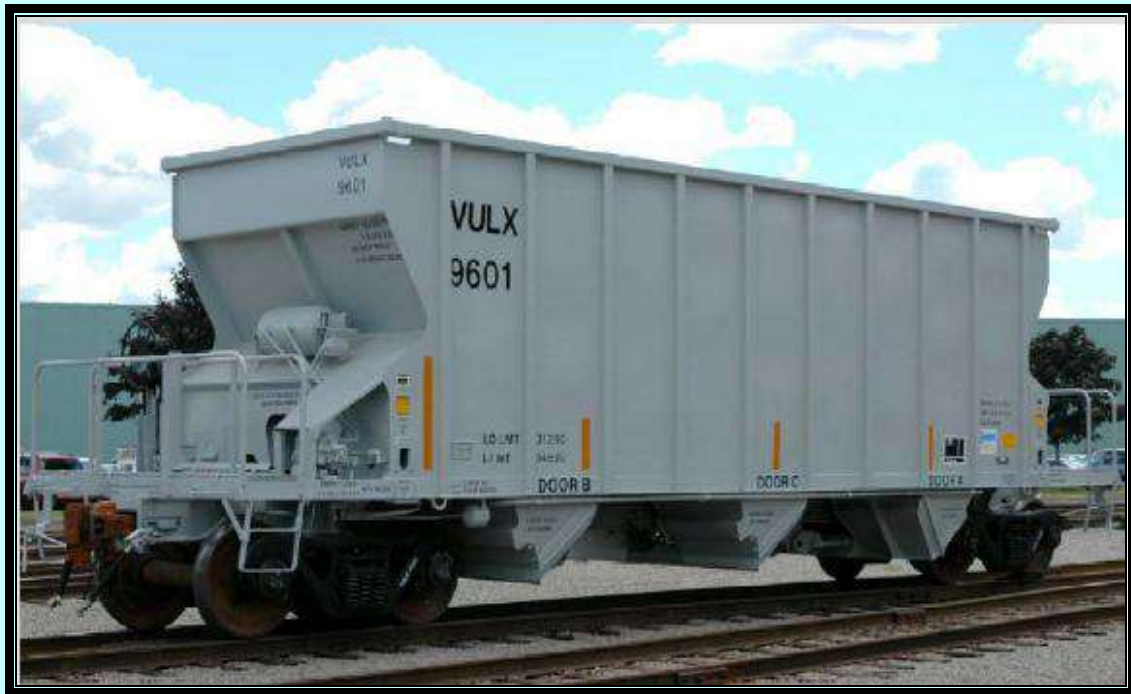
**TABLE 9.5****LIST OF RDSO MAINTENANCE PUBLICATIONS FOR TANK WAGONS**

<b>Sr. No.</b>	<b>Description</b>	<b>Name of Manual/Publication</b>
1.	Instructions for operation and maintenance of Bogie Phosphoric Acid tank wagon "BTPH"	G-71/June-92
2.	Instruction for operation and maintenance for BTAL/BTALN	G-79
3.	Instruction for operation and maintenance BG bogie tank wagon for Alumina type "BTAP" .	G-82/1988
4.	Maintenance manual for bogie liquified petroleum gas tank wagon type BTPGLN.	G-86/1994 Rev.-1
5.	Safe handling of Hazardous chemicals transported in Rail Tankers	G-87
6.	Instructions for Maintenance & operation for bogie petrol tank wagon type "BTPN"	G-90
7.	Instructions for Operation and Maintenance of Bogie caustic soda tank wagon type "BTCS"	G-83/1988



*( MAINTENANCE MANUAL FOR WAGONS- 2015 )*

# CHAPTER – 10



# SPECIAL TYPE OF WAGONS



## CHAPTER 10

### SPECIAL TYPE OF WAGONS

#### 1001. BOXNCR WAGON

##### a) SALIENT FEATURES

Bogie open wagon type BOXNCR is similar to BOXN wagon except the following:-

- i. Barring rolled sections, the wagon body is manufactured from steel to IRS M-44 instead of steel to IS: 2062 Fe410CuWA or IRSM-41.
- ii. Crib angles side to ISA 50x50x6 is manufactured from IRSM- 44 steel instead of IS: 2062 Fe 410 CuWA steel.
- iii. Sole bar is manufactured from IRSM-41 instead of IS: 2062 Fe Cu WA steel.

Other features like overall dimensions, bogie couplers and draft gear, brake gear, brake system, etc. are exactly same as BOXN wagon.

##### b) MAINTENANCE & REPAIR

- i. Since BOXNCR wagon is similar to BOXN wagon, the maintenance schedule and repair procedure shall be similar to BOXN wagon. However, since the wagon body is made from IRSM-44 steel, the body panels, when corroded, shall be replaced with IRSM-44 steel panels only. The IRSM-44 steel panels/plates shall be cut either by shearing machine or by plasma cutting machine but not by oxy-cutting. For latest instructions G-72 (latest version) should be referred. The welding electrodes to be used for repairs are indicated in table 11.2.

**TABLE 10.1 ELECTRODES FOR WELDING**

S. No	Material to be welded	Electrodes/filler wire to be used
1.	IRS M-44 to IRS M-44	IRS class M1 with IS code E19. 9LR16 (as per IS:5206-83) or 3081 (MIG) as per AWS.
2.	IRS M-44 to IS:2062/5986/1079	IRS class C2 basic coated low hydrogen type having IS code EB5426H3JX or EB5424H3JX as per IS:814-91.
3.	IRS M-44 to IRS M-41	IRS class D2 with high deposition.
4.	IS:2062/5986/1079 to IS:2062/5986/1079	Same as indicated in (2) above or CO2 filler wire as per IRS class I and IA.
5.	IRS M-41 to IRS M-41	Same as indicated in (3) above or CO2 filler wire as per IRS Class-III.
6.	IRS M-41 to IS:2062/5986/1079	Same as indicated in (5) above.

- ii. The edge preparation should be done as per IS:9595 for both “V” butt as well as fillet joints. Electrodes and filler wires should be procured from any RDSO approved sources and the parameters like current, voltage, etc. should be as per IS code and manufacturers recommendations. Preheating of electrodes of IRS class C2 & D2 at 250 deg. C for 2 hours, 350 deg. C for one hour or as recommended by the manufacturer be done prior to use. After heating, electrodes are to be kept in an electrode oven at 110° C to avoid any moisture pick up.

**c) PRECAUTIONS FOR WELDING STAINLESS STEEL**

- i. Since Stainless steel has high coefficient of thermal expansion and less heat conductivity, it is advised to use low welding currents with the recommended range and smaller gauge electrode to minimize heat input and reduce distortions.
- ii. Surface to be welded must be clean, dry and free from dirt, oxide film, oil, grease etc.
- iii. Electrodes should be re-dried before use.
- iv. Always maintain short arc to minimize the loss of alloying elements.
- v. Avoid weaving and make stringer beads.
- vi. After finishing welding, lift electrode slowly and fill the crater before breaking the arc. This will avoid crater cracks.
- vii. Use stainless steel wire brush for cleaning welds.
- viii. Use electrode preferably with DC(+).
- ix. Every bead should be properly cleaned before further welding on it.
- x. Welding should be preferably carried out in flat position.
- xi. Correct electrode size, recommended current, arc length, travel speed and electrode angle must be followed.
- xii. Any defect like crack, blowhole etc. must be properly gouged out and re-welded.
- xiii. Do not strike arc adjacent to the weld.
- xiv. Tack the welded area correctly to ensure proper gap.
- xv. Proper welding sequence must be followed to reduce internal stresses and hence reduce warpage of structure.
- xvi. Always weld towards the free ends.

**d) SURFACE PREPARATION & PAINTING**

- i. The surface preparation and painting schedule for underframe of the wagon shall be as per standard specification No.G-72 read with latest amendments.
- ii. **Surface preparation of the wagon body**  
Degreasing with petroleum hydrocarbon solvent to IS:1745-1978 (low aromatic grade 145/205) or any other degreaser (applicable for both SS,MS and corten steel).
- iii. **PAINTING OF WAGON BODY**  
**For stainless steel**
  - Apply thin coat of etch primer to IS:5666-1970.
  - Two coats of IS:2074-1992, ready mixed paint, air drying, red oxide zinc chrome priming to minimum DFT of 50 microns.

- Two coats of IS:123-1962, ready mixed paint, red oxide, brushing, finishing, semigloss to ISC:446 to IS:5-1994 to a DFT of 80 microns.

**For mild steel and corten steel**

- Remove dust, loose rust and mill scale etc. manually by scrapping, chipping and wire brushing to at least St.2 of IS:9954.
  - Two coats of IS:102-1962, ready mixed paint, brushing, red lead, priming to minimum DFT of 80 microns.
  - Two coats of IS:123-1962, ready mixed paint, red oxide, brushing, finishing, semi-gloss to ISC:446 to IS:5-1994 to a DFT of 80 microns.
- iv. The painting of bogies, couplers and air brake equipment shall be done as given in para 11.2.5 of General Standard Specification No. G-72 (Rev.1) read with latest amendments.

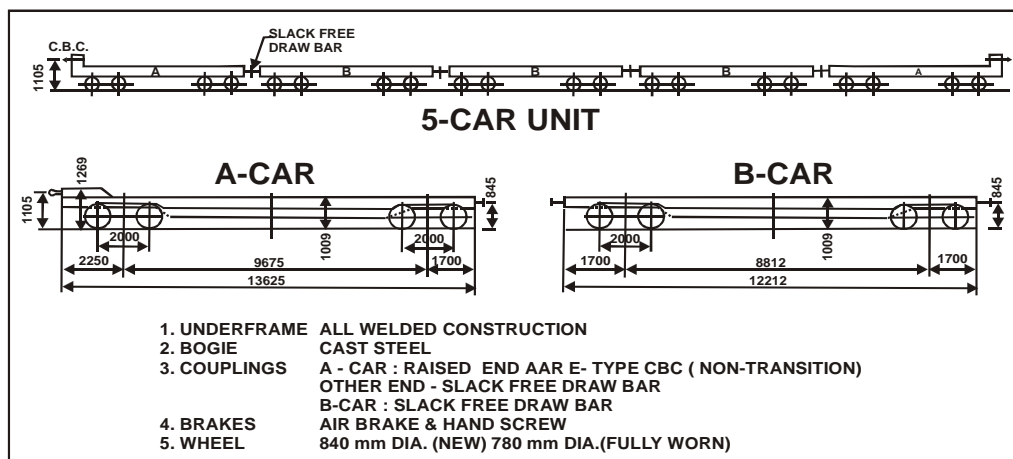
**1002. BOGIE LOW PLATFORM CONTAINER FLATS (BLC)**

Bogie container flat wagons have been designed for transportation of 2896 mm high Series-I, ISO containers for a gross payload of 61t at an operating speed of 100 km/h. These containers, when loaded on the earlier flat wagon caused infringement to the X-class MMD, resulting in constraints in their free movement.

In order to ensure that the wagons loaded with 2896 mm containers lie within the X- class MMD, a low platform height of 1009 mm has been achieved with the use of hybrid design of bogie frame and bolster and with the use of smaller diameter wheels (840mm).

The wagons have all welded construction and are mounted on two cast steel bogies. The flats are formed into units of five wagons, each unit having two “A” car at ends and three intermediate “B” cars. One end of “A” car is fitted with centre buffer couplers to ensure proper coupling with the locomotive while the other end has slackless draw bar to couple with “B” cars. “B” cars are coupled together and to “A” cars by slackless drawbars.

The length of A car over head stock is 13625 mm while the length of B car is 12212 mm. The coupler of A car for attaching to loco or other stock is at 1105mm. The coupler in the B car at both ends is at 845 mm from rail level. The wagons are equipped with Air Brake. The diameter of new wheel is 840 mm and the condemning size is 780 mm.



**Fig 11.1 : BOGIE CONTAINER FLAT WAGON**

## LOAD DISTRIBUTION

The weight distribution between centre pivot and side bearers is optimised to avoid hunting. 90% of the body weight under tare condition is borne by the side bearers which are of spring loaded design to ensure that no hunting takes place. The spring loaded side bearer arrangement has the distinct advantage of retaining the load distribution between centre pivot and side bearers irrespective of any manufacturing inaccuracies in the body and bogie bolster as well as the condition of the wheel (New or Worn). 10% of body weight under tare condition & full pay load will be borne by Centre Pivot.

## MAINTENANCE SCHEDULES

Short duration check-ups:

- i) **“B schedule” –every 3 months**
  - All items of intensive examination.
  - All dirt collectors, drain cocks should be drained.
  - Test Air Brake System to all the parameters as per test chart.
  
- ii) **“C schedule” –every 6 months**
  - All items of “B” schedule
  - Load Sensing Device (VTA) tip to stopper distance 16 mm be set if required.
  - Six months Schedule as prescribed by the Air Brake Manufacturer for the Air Brake System including the Pressure Reducing Valve may be maintained.
  - Check for defective or damaged Elastomeric pads

## BRAKE SYSTEM

The basic system conforms to the Graduated release, single pipe air brake system as per RDSO specification 02-ABR-02 (with latest amendment) together with the latest amendments using "Automatic, two stage empty/load braking control". This changeover from load to empty braking condition is provided by the distributor valve type C3W2/KE2CSLA which in turn is governed by two nos. of change over valves, type VTA/Single Piece Load Sensing device one on each bogie.

Since the wagon is designed to carry one or two containers, the various loading patterns arising in service may require sensing of load even in one bogie though the other may be in empty condition. In view of this, two nos. of Changeover valves are provided, one on each bogie, so that even if any of the bogies is under loaded condition, the VTA valve / Single piece Load Sensing valve installed in that bogie would actuate and deliver a signal pressure to the C3W2 Distributor valve or KE2CSLA Distributor valve.

## WAGON IN EMPTY CONDITION

Since the VTA valve/s/ Single piece LSD is/are not actuated in this condition, the compressed air at the inlet port of the VTA valve/s is/are not connected to the delivery ports of these valves. On the contrary, the delivery ports are connected to the atmosphere at the exhaust ports of the VTA valve/s.

In the absence of the signal pressure from any of these VTA valves, the empty load port of the C3W2 Distributor valve is connected to atmosphere and hence any brake application during this stage will be maintained in empty condition by the Distributor valve. However, irrespective of the empty or loaded Brake cylinder pressure, the Distributor valve maintains the specified application and release timings as per the specifications.

### **WAGON IN LOADED CONDITION**

If both the VTA valves/ Single piece LSD are actuated due to bogie deflection on both sides, the compressed air at the inlet ports of the VTA valves/ Single piece LSD is connected to the delivery ports which are interconnected at the 24-A Double check valve. Since the compressed air pressure to one of the VTA valves is maintained by the Reducing valve type N1 to be specifically lower than that which could come to the other VTA valve, the higher of the two delivery pressure from the VTA valves will push the shuttle inside the Double check valve to the opposite side and charges into the Distributor valve. Under the influence of the load sensing signal pressure, the Distributor valve generates a higher Brake cylinder pressure during all brake applications in this stage.

### **AUTOMATIC TWIST LOCKS (ATL)**

The automatic twist lock (ATL) is the compact container locating and securing device fitted at the locating points of under frame sole bar. These devices conform to specification AAR M-952. The older designs of ATL devices were having Rubber (Bonded) Torsion Springs in their internal mechanism. However the rubber bonded steel mechanism has been replaced with Steel Springs in new version of ATL devices.

A max. force of 800 lbs. is required for twisting the lock during entrance of the container and while removing the same force of 1600-2200 lbs. is required(Ref. AAR M-952).

The container is positioned so that the bottom aperture of the four corner castings are above the twist locks heads. The container is then lowered down slowly. The weight of the container causes the twist head to rotate and the corner casting slide past the twist head. Immediately after this the twist head rotates back in place engaging the corner casting and thereby securing the container.

If 20ft containers are used the locks on the middle should be kept in position. If the 40 ft. container is loaded to a wagon the middle locks mounted on folding brackets should be folded down before placement of 40ft. container on them.

**Note:** Use of crane with steel ropes for lifting containers is fraught with risks due to human error:

- Accidental falling of containers on under frame,
- Derailment of wagon due to failure of locks to get released at all locking positions,
- High risk of ATL/brackets damage etc.

***It is recommended that all loading/ unloading points/ ICD's (Inland Container Depots) handling BLC/BLCM/BLL wagons should use only Dedicated Reach Stacker Trucks for container handling.***



*Inspection, maintenance and general guidelines related to ATL devices has been issued under Technical Pamphlet no. G-100 (instruction for inspection & maintenance of automatic twist locks (ATL) devices fitted on container flat wagons OF Wagon/RDSO).*

### **1003. BROAD GAUGE BOGIE CONTAINER FLAT WAGON (BLLA & BLLB)**

#### **FEATURES OF THE WAGON**

The wagon is an all welded steel construction suitable for transportation of two 20 feet or one 40 feet ISO series-1 containers of maximum height 2896 mm (9'6") and width 2438 mm (8') per wagon and domestic containers of one 45' container or 2-22 container/one 20' & 24' container. The material used in the wagon construction is micro alloyed high strength steel to IS: 2062:E450.

Low floor height of the wagon from the use of low diameter wheel of 840 mm (in new condition), permits the loaded profile within the maximum moving dimension of standard X-class engine. The maximum axle load is 20.32 t and pay load 61.0 tonnes. The maximum operating speed of the wagon is 100 kmph in empty and loaded condition. The wagon can negotiate a minimum curvature of 175 m radius.

The wagons have been designed to work in units of 5 wagons consisting of two BLLA wagons (A-car) at extreme ends and three intermediate BLLB wagons (B-car). Outer ends of the A-cars are equipped with Non transition type center buffer couplers. Inner ends of A-cars and both ends of B-cars are fitted with slackless draw bars. The wagons are provided with cast steel two axle friction damped bogies and graduated release air brake system.

Net braking ratio in empty and loaded condition of the wagon is changed with the help of pneumatically operated load sensing device mounted on bogie bolster. Automatic twist locks are provided on the wagon for securing the containers during movement.

#### **BOGIE**

The wagon shall be fitted with two nos. of two axle cast steel bogies to Drg No. CONTR-9404-S/2 and Schedule of Technical requirements (STR) No. CONTR.LCCF-20 © (latest Rev.) issued by RDSO, Lucknow. The STR can be had from GM (Rolling Stock Design Division), 5th floor, RITES Ltd., RITES Bhawan, 1, Sector-29 Gurgaon-122001.

The bogies shall be fitted and supplied complete with top centre pivot, retaining ring, centre pivot pin with shackle lock and lock pin, spring loaded side bearers, suspension springs, friction wedge, brake rigging including brake shoes, elastomeric pads, wheel sets, bearings, wide jaw adapters, side frame keys with key bolt, nut and washer in a ready- to-use condition. The bogie shall be sourced from vendors approved by RDSO, Lucknow. The contractor shall ensure that all tests on the bogie have been carried out as per requirements contained in the above STR.

Elastomeric pad used between the bearing adapter and side frame crown shall be to RDSO Specification No. WD-30-Misc-99 (latest revision). The wheel and axle assembly shall conform to Drg. No. CONTR-9404-S/12 and RDSO specification R-19/93 Pt I. The wheels are solid cast or forged type. The tread diameter in new

condition is 840 mm and condemning size is 780 mm. The forged wheels shall conform to RDSO specification R-19/93 Pt-II and cast wheels to Specification R-19/93 Pt III. The wheel tread profile shall conform to RDSO Drg. No. WD-88021. The axle shall conform to RDSO Specification R-16/95.

Low friction type composition brake shoes (L- type) to Drg., No. CONTR-9404- S/11 and conforming to Specification No. WD-13-ABR-2003 or latest of RDSO, Lucknow. shall be used for tread braking. They shall be procured from RDSO approved sources.

Cartridge taper roller bearing of AAR ‘E’ type to RDSO schedule of Technical requirement (STR) No. AB-RB-39-2002 Rev.2 or latest suitable for 6”×11” journal shall be provided on the axle. The bearings shall require no field lubrication. Bearings shall be procured from sources approved by RDSO.

Grease to RDSO<sup>s</sup> Specification No. WD-24- MISC-2003 is to be used in CTRB. Before applying the grease, clean all the equipment to be used for lubrication. Apply grease to each single assembly and between the roller and cage assemblies in the quantity as given below:

**TABLE 10.2 Amount of grease to be applied**

To Single Roller Assembly (Each Cone Assembly)	Between Roller Assembly (Around spacer)	Total $\pm^{30}$ gm
115 gm	170 gm	400 gm

**BRAKE SYSTEM**

The wagon shall be equipped with single pipe graduated release compressed air brake system consisting of Distributor valve suitable for two-stage VTA type automatic load sensing device. The load sensing device shall be installed on the wagon as per Drg. No. CONTR-9405-S/16.

Particular attention should be paid to the clamping of pipes to wagon body and proper location of the cut-off angle cocks and hoses.

Complete air brake equipment including piping and joints shall be fitted on pattern wagon generally conforming to drawing No. 45-A-2001-S/13 for BLLA wagon and 45-A-2001-S/08 for BLLB wagon and offered to the engineer and the inspecting officer during prototype testing for approval. The contractor shall be obliged to carry out any modification on the layout of the air brake equipment, if required by the approving authority. Series production shall be as per the brake layout drawing approved for the prototype wagons.

Hand brake is provided on the wagon through two hand wheels on each side of the wagon as per Drg. No. 45-A-2001-S/11 for BLLA wagon & 45-B-2001- S/07 for BLLB wagon.

Brake rigging shall have double acting slack adjuster type IRSA-600 or equivalent. The brake system shall be thoroughly tested in all wagons using single car test rig.

## **AUTOMATIC TWIST LOCKS**

Ten numbers of twist locks shall be provided on each car as per drawing No. 45-A-2001-S/17 to facilitate positioning of one 40 feet or two 20 feet ISO containers and domestic containers of 45' or 2-22' containers or one 20' & one 24' container. The locks at the head stock ends are fixed type and those at middle of the car are retractable type to avoid infringement with 40 feet container.

## **1004. BOGIE COVERED DOUBLE DECKER WAGON TYPE BCACBM**

### **General:**

The Double Decker Wagon Type “BCACBM”, the broad Gauge Bogie Covered Auto-car carrier wagon to diagram drawing No.-11013-S-01 has been developed by RDSO for transportation of automobile cars. A rake of these wagons consists of 3 units; each unit consists of 9 wagons – 2 nos. wagons ‘A’ & 7 nos. wagons ‘B’. Both ‘A’ & “B” wagons have twin decks to accommodate cars. The upper decks of both wagons are movable to accommodate different heights of cars by diamond screw jack arrangement fitted in the wagon.

Wagon-A is fitted with CBC couplers on both ends with the coupler at one end at a designed height from rail level as 1105 mm, the other end incorporates CBC at a lower height of 861 mm. Wagon-B is fitted with CBC couplers on both ends at a designed height from rail level as 861 mm. Each unit shall be moved as one entity and the movement of individual wagon (i.e. Wagon A & Wagon B) shall not be done. The design incorporates LCCF 20(C) bogie with speed potential of 100 Km/h and single pipe graduated release air brake system. This wagon is fit to run up to a maximum permissible speed of 100 Km/h in empty and 95 Km/h in loaded condition.

The movement of the wagon on Indian Railway network shall be governed by the RDSO final speed certificate No. MW/BCACBM dated 27.02.2013 & its amendments issued from time to time.

**TABLE 10.3 NEW VARIANTS OF OLD WAGONS**

<b>S.No</b>	<b>Stock</b>	<b>Description</b>
<b>1.</b>	<b>BOBRNM 1</b>	In 2006 for operation up to CC+6+2 t, suspension of BOBRN modified by providing four additional springs, O-2 & I-2. Differentiated from BOBRN by a caption “Fitted with additional springs for A/L 22.232 t” in centre of wagon in Golden Yellow. Also, on bogie side frame Golden Yellow band provided. Speed 70/80 Kmph.
<b>2.</b>	<b>BOBRNHSM 1</b>	Designed in 2006. A/L 22.32 t. Variant of BOBRN with modified Casnub 22 HS bogie for increasing speed. Spring O-14, I-14, S-4. BOBRNHS was not manufactured, instead this was manufactured. Speed 60/65 Kmph.
<b>3.</b>	<b>BOBRNEL</b>	In 2008 for operation at 25t A/L, suspension of BOBRN modified by providing eight additional springs, Outer-2 & Inner-6. Bogie renamed as Casnub 22 NLC. Also, min. wheel tread diameter 950 mm min. axle wheel seat dia. 210 mm, reduction in POH to 3 years and ROH to 1 year and strict monitoring during maintenance prescribed. Differentiated from BOBRN by an Olive Green band. Speed restricted to 50/65 Kmph.
<b>4.</b>	<b>BCBFG</b>	<b><u>Bogie Covered Hopper Wagon for Food Grain</u></b> This wagon has been designated for transportation of food grain in Bulk. This wagon is designated with CASNUB-22HS MOD-I bogie, non transition CBC, single pipe graduated release air brake system with automatic load sensing device. There are two Nos. gravity discharge gates at bottom for unloading. A/L 21.82t. Speed 75/ 75 Kmph.
<b>5.</b>	<b>BVZI</b>	<b><u>Bogie Brake Van</u></b> This 8 wheeled brake van was designed in 2004 with ICF bogie to achieve comfort level (Ride Index) equivalent to loco criteria for goods guards and capable of running at 100 Kmph. The brake van is 5 meter longer than BVZC brake van.
<b>6.</b>	<b>BLLA/B</b>	<b><u>Bogie Low Platform Longer Container Flat Wagon.</u></b> Designed jointly by RDSO & RITES in 2001 for transportation of 22’, 24’, & 45’ container along with 20’ & 40’ long ISO containers. Lower height of under frame floor from R.L. has been achieved with introduction of hybrid design of bogie frame, bolster and use of smaller diameter wheel in LCCF 20(C) Bogie, Spring O-14, I-12, S-4, A/L 20.32 t. Speed 100/100 Kmph.
<b>7.</b>	<b>BLCA/B</b>	<b><u>Bogie Low Platform Container Flat Wagon</u></b> Designed in 1994 for transportation of 20’ & 40’ long ISO containers at an operating speed of 100 Kmph. Lower height of under frame floor from R.L. has been achieved with introduction of hybrid design of bogie frame, bolster and use of smaller diameter wheel in LCCF 20 (C) Bogie, Spring O-14, I-12, S-4,A/L20.32t Speed 100/100 Kmph.

8.	<b>Double Stake Container Operation</b>	In March 2006 double stack container train operation started with restricted speed of 75 Kmph. This was for the first time in the world that double stack container train operation on flat wagon was done. Speed 75/75 Kmph.
9.	<b>BLCAM &amp; BLCBM</b>	In year 2007 bogie of BLC wagon was modified by providing upgraded side bearer, upgraded friction wedge & two additional inner springs for double stack container operation at 22t axle load & 100 Kmph speed. Speed 100/90 Kmph.
10.	<b>BCACM</b>	In year 2007, to meet the immediate requirement of auto car industry, design of existing container flat wagons (A type & B type) modified by provision of a suitable bi level structure for transportation of auto cars. One rake can carry up to 270 auto cars. Two such rakes converted by Jagadhari workshops are in operation.
11.	<b>BOYEL</b>	In 2006 for operation at 25t A/L, suspension of BOY modified by providing four additional inner springs. Bogie renamed as Casnub 22NLC. Also. Min. wheel tread diameter 950 mm. min. axle wheel seat dia 210 mm reduction in POH to three years and ROH to 1 year and strict monitoring during maintenance prescribed. Differentiated from BOY by an Olive Green Band. Speed restricted to 50/65 Kmph.
12.	<b>BOXNM1</b>	In 2005 for operation up to CC+6+2 t, suspension of BOXN modified by providing four additional springs. O-2 & I-2. Differentiated from BOXN by a caption “Fitted with additional springs for A/L 22.82t” in centre of the wagon in Golden Yellow. Also, on bogie side frame Golden Yellow band provided. Speed 70/80 for CC+6+2t and 60/80 for CC+8+2t. For MGS –GZB route speed at CC+8+2t 75/80 Kmph.
13.	<b>BOXNEL</b>	In 2006 for operation at 25tA/L, suspension of BOXN modified by providing eight additional springs. O-2 & I-6. Bogie renamed as Casnub 22 NLC. Also, min. wheel tread diameter 950mm, min. axle wheel seat dia 210mm, reduction in POH to 3 years and ROH to 1 year and strict monitoring during maintenance prescribed. Speed 50/65 Kmph.
14.	<b>BOXNCR</b>	Designed in 1999. Material of body of BOXN changed to Stainless steel (IRS:M 44). Other parameters same as BOXN.
15.	<b>BOXNR</b>	Designed in 2007, it is upgraded rehabilitated version of BOXN. Entire superstructure of MS replaced with Stainless steel (IRS:M44). Height 177 mm more than BOXN. Carrying capacity increased by 6t. Nine Stanchions provided, instead of six in BOXN. Use of CRF section and lock bolting included. A/L 22.9t.
16.	<b>BOXNHA</b>	This wagon was designed in 1998 for transportation of coal to axle load of 23.5t/22.1t. Bogie: IRF 108 HS, Spring O-14 & I-14, S-4. Its height is more than BOXN. Serial manufacturing of this wagon was not undertaken due to constraint of some tipplers for handling these wagons. Cleared Speed at CC+8+2 t A/L of 75/100 Kmph.
17.	<b>BOXNLW</b>	Designed in 1988 to meet the requirement of higher pay to take ratio A/L 20.32 t. Casnub 22 HS bogie, Spring O-14 & I-

		12, S-4. Width 50 mm more than BOXN. Stainless steel (IRS: M 44) & Corton Steel (IRS: M41) used in body & under frame and Cold Rolled Formed (CRF) section were used in design to reduce the tare weight of the wagon. Manufacturing of this wagon started in 2005. Speed 100/100 Kmph.
18.	<b>BOXNLWM1</b>	In the year 2008, Designed and suspension of BOXNLW modified for operation up to CC+8+2 t in the design, centre sill was strengthen by providing three additional plates and in suspension two additional inner springs provided. As an interim measure , wagons not having strengthening of centre sill also allowed to operate up to CC+8+2 t with the instruction to carry out centre sill strengthening during POH and special checking of centre sill during ROH and once in a month. Speed 60/65 for both CC+6+2 t and CC+8+2 t.
19.	<b>BOXNHL</b>	Designed in year 2005, 250 mm longer, 76mm higher & 50 mm wider than BOXN, A/L 22.9 t. Casnub 22 HS with flat Centre Pivot, 'K' type CBB and break beam. Spring O-14 & I-14, S-4. Stain less steel (IRS: M44) and CRF sections used in body and under frame to reduce the tare weight (20.6 t) has improved quality coupler and draft gears. Lock bolts used for joining, instead of rivets. Brake Cylinder of 300 mm, IRSA 750 slack Adjuster, brake rigging different from BOXN Auxiliary reservoir 75 lit. PU painting provided Initially Red Oxide colour specified, later on changed to Phiroziblue. In red Oxide colour wagons 'SS' written on side in a circle in Phiroziblue colour for identification Speed 75/100 Kmph.
20.	<b>BOST</b>	Designed in year 2000 for long steel products. A/L 20.32t. CASNUB 22HS, Spring O-14, I-12, S-4. Speed 75/80, Operation at CC+6+2 also allowed as an interim measure with speed retraction of 50/80 Kmph.
21.	<b>BOSTM1</b>	In 2006 for operation up to CC+6+2t, suspension of BOST modified by providing two additional inner springs. Differentiated from BOST by a caption "Fitted with additional springs for A/L 22.32t in centre of the wagon in Golden Yellow. Speed 60/65 Kmph.
22.	<b>BOSTHS</b>	Designed in 2004. Variant of BOST with Casnub 22 HS (Mod-1) for increasing speed. Spring O-12, I-12, S-4. Differentiated from BOST by a Golden Yellow band. Speed 100/100 Kmph.
23.	<b>BOSTHSM1</b>	In 2007 for operation up to CC+6+2t, suspension of BOSTHS modified by providing four additional springs, O-2 & I-2. Differentiated from BOSTHS by caption "Fitted with additional springs for A/L 22.32tin centre of the Golden Yellow band. Speed 60/80 Kmph.
24.	<b>BOSTHSM2</b>	Designed in 2006 for increasing speed. A/L 22.32t. Variant of BOSTHS with Casnub 22 HS (Mod-II), Spring O-12, I-12, S-4. Speed 60/100 Kmph.
25.	<b>BCNM1</b>	In 2006 for operation up to CC+8+2t, suspension of BCN modified by providing four additional springs. O-2, I-2. Differentiated from BCN by a caption " Fitted with additional springs for A/L 22.32t" in centre of the wagon in Golden Yellow band provided. Speed 75/80 for CC+6+2t and 60/80

		KmphCC+8+2t.
26.	<b>BCNAM1</b>	In 2006 for operation up to CC+8+2t, suspension of BCNA modified by providing four additional springs. O-2, I-2. Differentiated from BCNA by a caption “Fitted with additional springs for A/L 22.82t” in centre of the wagon in Golden Yellow. Also, on bogie side frame Golden Yellow band provided Speed 75/80 for CC+6+2t and 60/80 Kmph CC+8+2t.
27.	<b>BCNAHS</b>	Designed in 2001. Variant of BCNA with Casnub 22HS bogie for increasing speed. Spring O-14, I-12, S-4. Differentiated from BCNA by a Golden Yellow band. Speed 100/100 Kmph.
28.	<b>BCNAHSM1</b>	In 2006 for operation up to CC+8+2t, suspension of BCNAHS modified by providing two additional inner springs.. Differentiated from BCNAHS by a caption “Fitted with additional springs for A/L22.82t. In centre of the Golden Yellow band. Also, on bogie side frame Golden Yellow band provided. Speed 75/100 for CC+6+2t and 75/100 Kmph for CC+8+2t.
29.	<b>BCNHL (Covered Wagon)</b>	Designed in 2006 for bagged commodities. A/L 22.9t. Length reduced, width and height increased then BCNA. Number of wagons per rake increased to 58. Casnub 22 HS with Centre pivot, ‘K’ type CBB and brake beam. Spring O-14, I-14, S-4, Stainless steel (IRS: M44) and CRF sections use in body and under frame to reduce the tare weight. Has improved quality Coupler and draft gears. Lock bolts used for joining, instead of rivets. Brake Cylinder of 300mm, IRSA 750 Slack adjuster, brake rigging different from BCNA. Auxiliary reservoir 75 litre. PU painting provided, Phiroziblue, Speed 75/70 Kmph.
30.	<b>BRNAHS</b>	Designed in 2001. Variant of BRNA with Casnub HS bogie for increasing speed. Spring O-14, I-12, S-4. Speed 100/100 Kmph.
31.	<b>BFNS</b>	Designed in 2002 specially for transportation of hot rolled/ cold rolled coils, plates, steels and billets etc. This first wagon designed in Indian Railway to carry point load. Casnub HS bogie, Spring O-14, I-12, S-4, A/L 20.32t. Speed 100/100 Kmph.
32.	<b>BRHNEHS</b>	This bogie rail wagon was designed in 2004 for use of Engineering department of various Zonal Railways for Track Relaying Trains (TRT), specially for loading RCC sleepers, Axle Load 20.32t. Casnub 22 HS, Spring O-14, I-12, S-4. The design was provided with Transition CBC and air brake system. Speed 50/65 Kmph.
33.	<b>BOBSNM1</b>	In 2006 for operation at 25t A/L, suspension of BOBSN modified by providing four additional inner springs, Bogie renamed as Casnub 22 NLC, Speed 50/60 Kmph.

34.	<b>BOBRM1</b>	In 2006 for operation up to CC+6+ 2t, suspension of BOBR modified by providing four additional springs, O-2 & I-2. Differentiated from BOBR by a caption “Fitted with additional springs for A/L 22.32t in centre of wagon in Golden Yellow. Also, on bogie side frame Golden Yellow band provided. Speed 70/75 Kmph.
35.	<b>BTPGLN</b>	Bogie liquefied petroleum gas tank wagon, tare 41.60t, CC 37.6 t, and Gross 79.20 t. The wagon is fitted with Air brake system, Casnub 22 NLB bogie, O-12, I-8, S-4. A/L20.32t. Speed 75/80 Kmph.
36.	<b>BOXNHAM</b>	A variant of BOXNHA wagon achieved by conversion of BOXN type wagons during POH/Rebuilding. Axle Load: 22.82 t Bogie: IRF 108 HS, Spring O-14 & I-14, S-4. Conversion being done through operation of Railway Board RSPs. Cleared Speed at CC+8+2 t A/L of 75/100 Kmph.
37.	<b>BCACBM</b>	A new design of Bi-level Auto Car Wagon type ‘BCACBM’ has been developed by RDSO for transporting Automobiles Cars. It has movable middle deck permitting freedom to load all types of cars, lower floor height of 938 mm with existing LCCF bogie (840mm dia. wheel), single pipe graduated release air brake system, Max. Permissible speed of 100 Kmph in empty and 95 Kmph in loaded condition. Axle load is 12.715 T for Wagon-A and 12.680 for Wagon-B.
38.		
39.		
40.		



*( MAINTENANCE MANUAL FOR WAGONS- 2015 )*

# **CHAPTER – 11**



# **INFRASTRUCTURE FACILITIES**



## CHAPTER – 11

### INFRASTRUCTURE FACILITIES (For Freight yard, Sick line and ROH Depots)

#### 1101 Introduction:

To achieve best performance of freight stock it is necessary that these stocks are maintained properly. The maintenance pattern and practices to be followed have been described in the previous chapters of this manual. However, despite of best practices and trained manpower, proper maintenance, availability and reliability of assets cannot be achieved if adequate infrastructure is not available. Accordingly, the Railway Board has laid great stress on review and improving availability of required infrastructural facilities for maintenance and vide their letter no. ERB – I/ 2006/ 26/ 46 dated 14.12.06 nominated an ED's committee for rationalization of train examination points, sick lines and ROH depots. The criteria for categorization of examination/repair facilities recommended by the ED's committee are as under (Ref: Bd's letter no. 96/ M(N)/ 204/ Vol -I/ II dated 09.03.04, 02.11.04 and 05.08.04)

#### A. Categorization of Examination / Repair facilities

<b>I. Intensive Examination Points</b>	
<b>Category</b>	<b>Criteria for Categorization</b>
<b>A</b>	(i) Having pucca pathways on more than 50% of the lines nominated for examination.
	(ii) Sufficient illumination facilities 150 lux.
	(iii) Sufficient material handling facilities.
	(iv) Sufficient welding facilities.
<b>B</b>	(i) Having pucca pathways on more than 50% of the lines nominated for examination.
	(ii) Sufficient illumination facilities.
	(iii) Sufficient material handling facilities.
<b>C</b>	(i) Having pucca pathways on more than 50% of the lines nominated for examination.
	(ii) Sufficient illumination facilities.
<b>D</b>	(i) Having pucca pathways on more than 50% of the lines nominated for examination.
<b>E</b>	No pucca pathway but some other facilities are available
<b>F</b>	No facilities available.
<b>II. ROH Depots</b>	
<b>Category</b>	<b>Criteria for Categorization</b>
<b>A</b>	Where all the infrastructural facilities are adequate.
<b>B</b>	Where all the infrastructural facilities are available but some not adequate to match target out turn
<b>C</b>	Where some vital infrastructural facilities like EOT crane/wheel turning lathe etc. are not available, other facilities are adequate.
<b>D</b>	Where facilities are grossly inadequate or non-existent.

<b>III. Sicklines</b>	
<b>Category</b>	<b>Criteria for Categorization</b>
<b>A</b>	(i) Berthing capacity under covered shed
	(ii) Heavy duty concrete flooring in working area.
	(iii) Availability of welding facility.
	(iv) Availability of Compressor/ Exhauster.
	(v) Availability of EOT crane
<b>B</b>	(i) Berthing capacity under covered shed.
	(ii) Heavy duty concrete flooring in working area.
	(iii) Availability of welding facility.
	(iv) Availability of Compressor/ Exhauster.
	(v) Synchronized whiting jacks.
<b>C</b>	(i) Berthing capacity under covered shed.
	(ii) Heavy duty concrete flooring in working area.
	(iii) Availability of welding facility.
	(iv) Hydraulic Jacks for lifting
<b>D</b>	(i) Berthing capacity under covered shed.
	(ii) Heavy duty concrete flooring in working area.
<b>E</b>	Berthing capacity under covered shed.
<b>F</b>	Without any Berthing capacity under covered shed.

The details of infrastructural facilities required for examination yards, sicklines and ROH depots are described in subsequent paragraphs.

## **1102. INFRASTRUCTURE & FACILITIES REQUIRED IN THE YARD**

- i. Centre to centre distance between tracks for nominated lines for conducting intensive examination should be minimum 7.5 meters.
- ii. Concrete pathways, material handling equipment, multi utility vehicle to facilitate movement of man and material smoothly from one end to other end.
- iii. Proper illumination, specially covering bogies and brake gear locations so that the wagons needing attention can be easily detected.
- iv. Welding grid on the entire length of train of nominated line with proper earthing arrangement so that welding can be carried out without marking the wagon sick.
- v. Enough outlets for tapping air pressure for testing of the stock.
- vi. Duty room for Section Engineer/Junior Engineer (C&W), staff room, air compressor room, store room for stocking material, tool room, welding machine room, battery charging room etc.
- vii. VHF sets / CUG phones for close monitoring and communication between supervisors, staff and Sr. Section Engineer (In-charge).
- viii. Portable LED type inspection lamps.

### **A. MACHINERY & PLANT ITEMS**

The following machinery and plant are essential for train examination during yard maintenance:

- Diesel and Electrically driven Compressor
- Welding plants
- Wagon /Rake Test rig

- Hydraulic jacks of various capacities.
- Lister truck for carrying material such as brake blocks etc.
- DG set (Cap. 200 kva min.)
- Multi utility vehicle for transportation of Men, Materials and Tools from one end of rake to other.
- Gas/ Plasma cutting set .

## **B. TOOLS**

*Fitters should have the following tools.*

- Tool Bag
- Hammer
- Chisel
- Punch (Flat & Round End)
- LED head lamp
- Spanners of various sizes
- Pipe wrench
- Wheel tyre defect gauge
- Measuring foot rule
- Measuring tape
- Non contact hot axle detector
- Cord for measuring spring camber
- Gauge for measuring “A” dimension
- Test plate
- “GO /NO GO” gauges

**To be made available in Section Engineer/Junior Engineer (C&W) office**

- All types of jacks
- Banner flag/Tail lamp
- CBC height gauge
- Air pressure gauge
- Chisel with wire handle
- Punch with wire handle
- Sledge hammer
- Scale – Steel rule 6”
- Measuring tape – 3 m
- Allen key (full set)
- Circlip plier (internal & external 19-60 mm)
- Hacksaw with blade 12”
- Set of non sparking tools (for yard handling tank wagon)
- LED head lamp
- Helmet
- Ladder with platform 10 ft. height

### **1103 INFRASTRUCTURAL FACILITIES FOR FREIGHT EXAMINATION YARD WITH WORLD CLASS FACILITIES FOR DETECHMENT FREE YARD (IF PROPOSED).**

**(Ref.: CAMTECH's Report No.CAMTECH/2007/M/W/Infra/1.0 Jan- 2008)**

- i) The yard handling 5 to 10 rakes per day shall have two examination lines of 750 m each to facilitate creation of gap, one line for keeping sick wagons and one line for keeping fit wagons released from sickline. All the four lines should be under covered shed to facilitate all weather working.
- ii) The complete area of examination yard shall be provided with abrasion resistance granolithic concrete flooring and ballast free embedded track to ease movement of vehicles and material handling equipments.
- iii) Centre distance between the examination, sick and fit line shall be 7.5 m to ensure free movement of material handling equipments and minor attention.
- iv) No OHE wiring over the examination lines/Sick yard line /fit wagon line which shall be dealt with EOT crane.
- v) Top wiring at both the ends of the train examination line for dropping the rake and waiting for crew/loco after release.
- vi) TXR shall be provided with Industrial type Personal Digital Assistant (PDA) having pre-fed check sheets for recalling defects and examination data.
- vii) A dedicated engine for placement of rakes in examination line if the rake is received with electric locomotive.
- viii) A rail cum road shunting vehicle with capacity to haul 30 empty wagons shall be used for creating gaps between wagons. The vehicle shall also be provided with compressor and rake test rig for air brake testing of formations.
- ix) For yards handling upto 10 rakes per day, 7 EOT cranes of 30 tonnes lifting capacity, 30 mtrs. Span and 650 mtrs.travelling shall be provided. Each wagon shall be lifted with the help of EOT cranes by using specially designed slings for lifting from axle box.
- x) Major Sickline with all Infrastructural facilities would remain attached and adjacent to freight examination yard.
- xi) To expedite repairs in-situ, adequate number of material handling vehicles and multi utility vehicles shall be provided.
- xii) The covered shed shall be provided with alternate rows of metal halide lamps and set of T-5 tube light fittings. The illumination around covered shed should be provided by high intensity tower lights.
- xiii) Electric panel with junction box at a distance of 30 m shall be provided in between sick yard line and examination line.
- xiv) Effective communication system preferably CUG mobile phones or walkie talkie sets shall be provided across teams.
- xv) A comprehensive contract for day to day upkeep of the yard is recommended for major and mega yards. This contract should cover items like scrap lifting and bush cutting in the periphery of the yard.
- xvi) A running contract for petty repairs pertaining to shed and floor of the yard including civil and electrical engineering works is also recommended. This contract will be monitored by field officer of Mechanical Department.
- xvii) A running contract for maintenance of all major M&P such as EOT cranes, compressor, vehicles, welding sets, hydraulic jacks is also recommended.

## 1104. INFRASTRUCTURAL FACILITIES IN AIR BRAKE ROH DEPOTS

Air brake depots have been classified based on the target capacity for ROH outturn/month as follows:

Category	Targeted capacity for ROH (Average/month)
Super Depots	Above 500
Mega Depots	250 to 500
Major Depots	125 to 250
Minor Depots	Upto 125

### A. RECOMMENDED LAYOUT

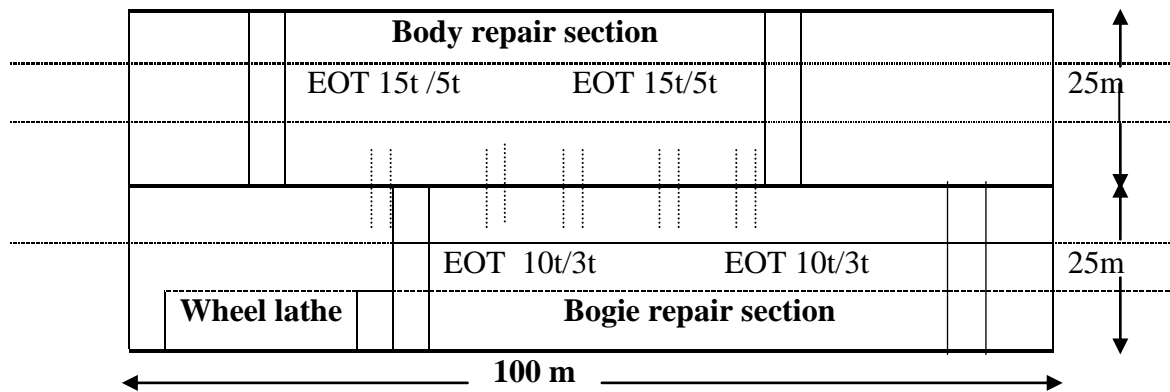
Analysis of sick marking of existing ROH depots on IR reveals that on an average each air brake wagon visits the depot thrice in 18 months, once for schedule ROH and twice for out of course repairs requiring lifting.

Therefore, an air brake depot meant for undertaking 250 ROHs/month needs to tackle another 500 wagons/month out-of-course repairs requiring lifting. Thus the layout should be spacious enough to release about 25-30 wagons/day.

The ROH schedule should be completed within 24 hours including placement and withdrawal time. Thus, if the depot has to undertake 250 ROHs/month the berthing capacity for ROH wagons **on trestles** should be 12 taking 20% margin for heavy repairs. Considering a mixed ROH outturn and the working length for BOXN as 15m & BCN/BTPN as 20 m, the length of the ROH depot works out as 100 m.

Casub bogies require extensive repairs of bogie components. These bogies need to be tackled on bogie manipulators to ensure down hand welding. All wearing surfaces need to be built up to original (new) sizes. Further, all modifications issued by RDSO need to be implemented to ensure adequate safety. The bogie section is required to supply 20 bogies/day for undertaking 250 ROHs/month apart from repairing bogies required for out-of-course repairs. For this purpose, adequate work stations need to be set in a crange area of about 2500 sq.m. (including wheel lathe area).

**Recommended layout of bogie and body repair section for a Major depot undertaking 250 ROHs per month along with sick line work of out-of-course repairs is given on next page:**



Further details of the model layout and its end view are given in the attached Fig. II-A. The above layout has to be supplemented with facilities for Stores, machine shop, smithy shop, air brake equipment overhauling sections, model room, compressor room, canteen, hostel, etc. which will largely depend on the existing layout.

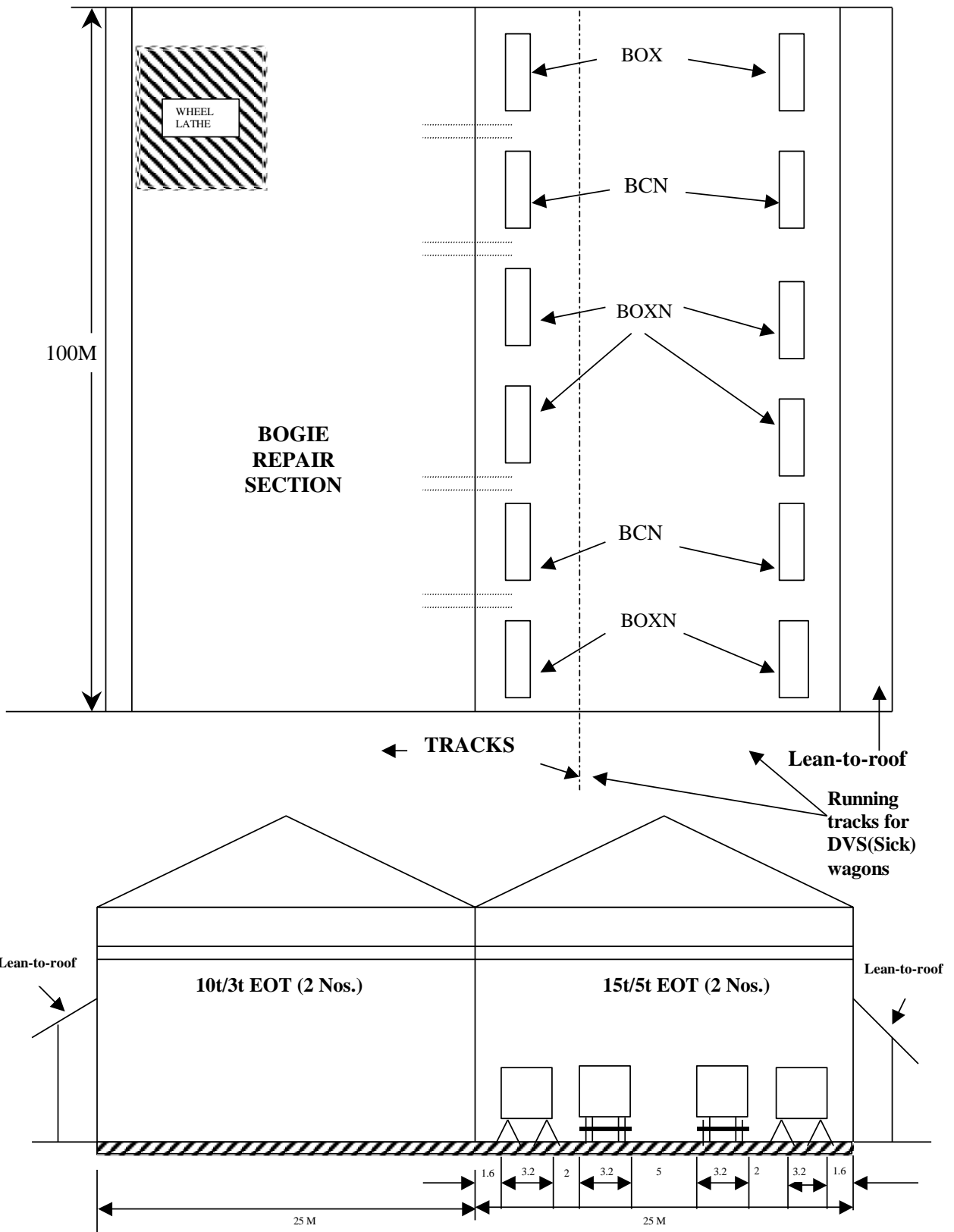
Covered area under cranes i.e. crange area for a fixed ROH outturn is a function of placement/withdrawal and number of working shifts. The recommended crange area for depots undertaking 250 to 500 ROHs per month is given below:

<b>1. For ROH depots with Sick-line attention</b>		
250	<b>ROHs/month</b> + sick line repairs with double shift.	5000 sq. m including wheel lathe shed.
300		5600 sq. m.
350		6200 sq. m.
400		6800 sq. m.
450		7400 sq. m.
500		8000 sq. m.

<b>2. For ROH depots WITHOUT Sick-line attention</b>
Depots undertaking only ROH workload and no out-of-course repairs can manage the outturn of 250 ROHs/month in about 3000 sq. m. crange area working in double shifts.



**B. MODEL LAYOUT FOR UNDERTAKING 250 ROHs/ MONTH**



**Fig. II-A**

### C. REQUIREMENT OF MACHINERY AND PLANTS

M&P requirement is closely linked with the Depot layout and the system of working. Certain M&Ps are directly related to outturn of depot (e.g. welding machines) but certain M&Ps are related to depot layout, especially material handling equipment. Various repair centres/sections in a depot are as follows:

1. Body shop
2. Bogie shop
3. Air brake equipment
4. Wheel reconditioning
5. Machine shop & material reclamation
6. Stores
7. Black smithy shop
8. Training equipment
9. Canteen & Staff amenities
10. Management information system
11. Office equipment
12. CMT laboratory
13. Miscellaneous.

Recommended list of M&P for a unit depot i.e. handling 250 ROH per month is given below. For a depot handling more than 250 ROH per month, the requirement has to be scaled up depending on depot layout and facilities created. Requirement of M&P for each section is given below:

#### 1. Body section

Sr. No.	M&P	Quantity
1	EOT cranes 15t/5t	2 Nos.
2	Welding machines	4 Nos.
3	Portable hydraulic rivetter	1 Nos.
4	Trestles	12 sets
5	Winches	As per layout
6	Portable Grit Blasting Machine	1 No.
7	Lock bolting machine	02 Nos.
8.	MIG welding sets	02 Nos.
9.	Plasma /Gas cutting	04 Nos.

#### 2. Bogie section

1	EOT crane 10t / 3t	2 Nos.
2	Welding machines	6 Nos.
3	Portable hydraulic riveter	1 Nos.
4	Stores bin	50 Nos.
5	Portable electric grinders	3 Nos.
6	Jib crane 2.5t	10 Nos.
7	Fixture for rivetting spring plank	2 Nos.
8	Work station for bogie repair	10 Nos.
9	Turn table for wheel sets	As per layout.
10	Road crane 10t capacity	1 No.
11	Bogie manipulators	3 Nos.
12	Roller bearing diagnostic equipment	2 Nos.
13	Magnetic flaw detector	2 Nos.
14	CO <sub>2</sub> welding machine	2 Nos.

**3. Air brake equipment**

1	Elec. Stationery screw air compressor completes with air receiver 15 m <sup>3</sup> /min (This is for depot only. Additional compressors will be required for yard).	1 No.
2	Portable diesel compressor	1 No.
3	Single Wagon test rig	2 Nos.
4	DV test stand	1 No.
5	Hydraulic pipe bending machine	1 No.
6	Air conditioners with voltage stabilizer	2 Nos.
7	Torque wrench with various sizes of sockets less than 1 inch.	4 set.
8	Ultrasonic cleaning table for DV components	1 Nos.

**4. Wheel Reconditioning Equipment**

1	Surface wheel lathe with Servo controlled voltage stabilizer	1 No.
2	Pneumatic torque wrench with sockets 1" to 2"	4 sets
3	Pressure grease drum with guns 15t capacity.	2 Nos.
4	Ultrasonic flaw detector	2 Nos.
5	Bearing marking gadget	1 set
6	Mono-rail for handling swarf (detail plan will depend on layout)	1 set
7	Bins for storing bearings	As per requirement
8	Fork lifter 2.5t	1 No.
9	P.C. Terminal	1 No.
10	Wheel diameter measuring gauge	2 Nos.

**5. Machine shop & material reclamation**

1	Heavy duty shaping machine	1 No.
2	Jib crane 2.5t	1 No.
3	Centre lathe 12 ½" cap.	1 No.
4	Radial drilling machine	1 No.
5	Centre lathe 6" cap	1 No.
6	Bench drilling machine	1 No.
7	Heavy duty pedestal grinder double ended	1 No.
8	Shearing machine 6 mm	1 No.

**6. Stores**

1	Truck 10t capacity	1 No.
2	Tractor with hydraulic lifting machine and 3 trolleys (trailers)	1 No.
3	Fork lift 2t	2 No.
4	Platform truck 2t	2 Nos.
5	Battery charger	2 No.
6	Weighing machine 500 kg	1 No.
7	Light store vehicle	1 No.
8	Hand trolleys with rubber wheels	10 Nos.
9	Storage racks	As per layout

10	Computer terminal with printer	1 No.
11	Furniture	As per layout

### 7. Training equipment

1	Cut models of DV, SAB, Angle cock.	1 set (each)
2	Television /DVD player	1 set
3	Furniture	As per reqt.
4	Hostel along with kitchen equipment	As per requirement
5	LCD projector	1 No.
6	PC	02 Nos.

### 8. Canteen & staff amenities

1	Water cooler	3 Nos.
2	Stainless steel tables & chairs	As per reqt.
3	Kitchen equipment, cooking gas, utensils	As per reqt.
4	Fitter's lockers	As per reqt.

### 9. Office Equipment

1	PC terminal	As per reqt.
2	Printer	As per reqt.
3	Furniture	As per reqt.
4	Air conditioner & computer room.	As per reqt.
5	Intercom 10 lines	1 No.
6	Fax with P&T line	1 No.
7	First aid equipment	4 set
8	Photocopier	1 No.
9	V.H.F. / CUG phones	As per reqt.

### 10. Miscellaneous

1	Gas cutting equipment	4 Nos.
2	Hydraulic jacks	As per reqt.
3	SAB test bench	1 No.
4	CBC and draft gear replacement equipment	2 sets
5	DG set 350/500 KVA	1 No.
6	Electric and pneumatic tools	As per reqt.
7	Rivetting equipment	As per reqt.
7	Fitter's hand tools.	As per reqt.
8	Gauges & instruments.	As per reqt.
9	Wheel flat detector system (*)	As per reqt.

(\*) To be installed in depots/yards as per instructions of Railway Board.

**Note:** Where power failures are rampant, a Diesel Generating Set to run the wheel lathe and cranes may also be planned.

## 1105. FACILITIES REQUIRED FOR MAINTENANCE OF STAINLESS STEEL WAGONS:

Facilities ( M&Ps and consumables) for maintenance of stainless steel wagons in freight yard, sick line and ROH depot:

S.No.	Item/description	Freight Yard (maintaining 3 rakes/ day)	Sick line (5 wagons /day)	ROH Depot (ROH/month 200 wagons)
1.	<b>MIG/MAG Welding Sets (400 Amp.)</b>	02 Nos.	02 Nos.	03 Nos.
2.	<b>DC Arc Welding Rectifier (600 Amp.)</b>	02 Nos.	02 Nos.	03 Nos.
3.	<b>Portable Air Plasma cutting machine</b> (max. capacity 16 mm)	02 Nos.	02 Nos.	03 Nos.
4.	<b>Consumables for Air Plasma M/c i.e. torch tip, catalyst etc</b>	As per requirement		
5.	<b>Welding electrodes</b> (For IS2062 to IRS-M44 and IRS-M44 to IRS-M44)	As per requirement		
6.	<b>Lock Bolts of various sizes</b>	As per requirement		
7.	<b>Lock bolts equipment</b>	2 Sets	2 Sets	3 Sets
8.	<b>Portable grinding machine</b> (only dedicated grinding wheels & disc should be used)	03	03	05
9.	<b>Stainless steel wire brushes</b>	As per requirement		
10.	<b>SS (IRS-M44 ) plates</b>	As per requirement		
11.	<b>CRF section (IRS-M44)</b>	As per requirement		




**Note:** The class of welding electrodes for different combinations of materials shall be as per RDSO document no.G-72.




## **1106 MINIMUM INFRASTRUCTURE REQUIRED FOR PREMIUM & CC EXAMINATION**

The following infrastructural facilities are considered essential to carry out premium examination in less than 03 hrs.




- Dedicated two or more examination lines with pathways (depending upon nos. of rakes examined)
- Embedded track/ Pucca pathway of 02 m width as per layout
- Welding facilities and Portable welding set
- Adequate illumination
- Pallets for material storage/dispensing
- Road between office/store and examination yard
- Connectivity with FOIS
- Walkie Talkie sets
- Provision of MUV (e.g.Tata Ace truck) for transportation of staff and materials/equipments to examination point
- Rechargeable LED head lamp

## 1107 Facilities required in Freight Examination Yards

SN.	DESCRIPTION	Facilities
1.	Examination Line	<p>Dedicated examination lines should be available in yards for CC examination with full CSR</p> 
2.	Path Ways	<p><b>Total Pathways: CC Pathways should be provided for movement of listers and to facilitate examination staff in train examination</b></p> <p><b>Length</b> – Approx 700m each to be constructed alongwith cross pathways for cross movement at the end of the line.</p> <p><b>Width</b> – Min. 3.0 metrs and max.7.0 meters</p> 
3.	Illumination facilities to be provided in yard & pathways	<p><b>a). High Masts:</b> High tower lights to be provided in yard for getting general illumination in lines and pathways. Atleast 04 tower in one yard are desirable.</p> <p><b>b). Normal Tower</b> – Boom lights may also be thought of for providing suitable electrical fittings on both side of boom at suitable height</p> <p><b>c). Lamp Post on pathways:</b> Water proof light fittings with independent switching arrangement to facilitate train examination staff. <b>(At an equal distance of 12/20 m).</b></p> 

4.	<b>Welding Transformer Room</b>	
5.	<b>Fitting of welding terminals at pathway</b>	<p>Welding connections should be provided on the lighting pole for easy connectivity to the welders. The parallel earthing connections should also be given at an equal distance of 20 m interval.</p> 
6.	<b>Air Compressor</b>	<p>Suitable capacity 02 nos. compressor units should be provided with the provision of Air Dryer for feeding air pressure to Rake Test Rigs.</p> 
7.	<b>Location of Testing points</b>	<p>Rake testing Rigs fitted with air flow indicator and digital BP &amp; FP Pressure gauges should be provided at one end of the yard.</p>
8.	<b>Tools</b>	<p>Standard Tool boxes with containing of tools &amp; gauges as recommended by CAMTECH should be available in yard for each gang.</p>
9.	<b>Sub-Store</b>	<p>Provision of Field store should also be ensured for unit exchange in shifts for shift incharges. Proper ledger should also be maintained for consumption.</p>



		
10	<b>Staff Strength (Per shift)</b>	<b>1) Examination Gang</b> Total two nos. of examination gangs may be provided with welder in each gang.
		<b>2) Testing Gang – As per requirement</b>
		<b>3) Dispatch Gang: As per requirement for Axle box felling &amp; pressure continuity etc. in Yard.</b>
		<b>4) Rolling in exam. &amp; Axle Box felling</b> As per requirement for rolling in examination and operation of non contact thermal sensors for axle box feeling.
	<b>Total Staff</b>	<b>As per bench marking given in the Wagon Maintenance Manual</b>
11	<b>Examination Time (Average)</b>	Examination time should be minimized in the yards by providing light fittings for examination of CC rakes during nights also. Required components should be transported in advance & provided on the pathways for fitment in the required wagons.
12	<b>Average Rake Examination/Month</b>	Record of average train examinations must be maintained in the yard office and layout plan should be displayed with facilities for easy understanding of inspecting officials.
13	<b>Work attention when Gang is Idle</b>	Primarily work should be Sick repair along with Scrap collection from examination lines.
14	<b>FOIS</b>	FOIS connectivity should be provided in the yard office as well as in the Divisional office & trained staff should be placed for monitoring etc.
15	<b>Material Handling</b>	<b>Mobile work station</b> equipped with gas plants and spares. The material handling listers should be used for material transportation in all examination lines.
		 

*( MAINTENANCE MANUAL FOR WAGONS- 2015 )*

# APPENDIX



**I, II, III, IV, V, VI, VII,  
VIII, IX, X, XI & XII**



**APPENDIX- I****TIPPLER****1.0 Introduction**

The tippler machines are used by private siding owner for tipping of BOX 'N' wagons loaded with coal. The loaded wagons are marshaled in the tipping line and placed on the tipping unit one by one for unloading.

**Types of tipplers:** There are two types of tipplers being installed in the pvt. Sidings.

1. Side discharge tippler
2. Rotary type wagon tippler

**2.0 General requirements**

2.1 The design and construction of components of tipplers and auxiliary handling equipment coming into contact with any part of wagon shall be such that no damage whatsoever is caused to the wagon equipment or its paint.

2.2 The top clamping pressure shall be such as will hold the wagons firmly in position on rails and keep the running gear from getting dislodged without causing any deformation to the wagon structure.

2.3 Adequate compensating measures shall be taken in top clamps and side support beam to compensate for manufacturing imperfections, within the permissible limits, in the top copings and side stanchions of the wagon, so that clamping pressure on the contacting area on the side and top of the wagon is uniformly distributed.

2.4 The side supports for tipplers shall meet the following requirements:

- a) The side support shall consist of a longitudinal beam, which shall be as long as the longest wagon to be tipped. This beam shall be continuous.
- b) The side support shall be articulated so that it can take the tapered as well as parallel stanchions on the body of the wagons. Alternatively, the cradle shall be articulated on trunion to achieve this.
- c) Full-face contact between the side support beam and the side stanchions shall be ensured. The side supports shall extend from a height of 1000 mm up to 2950mm, from rail level, i.e. contact the side of the wagon over a width of not less than 1950mm. [For wagons of height less than 2950mm, typically iron ore wagons, (user shall have to consult the concerned zonal railway for this confirmation) suitable slots shall be provided in the side support beam, to permit the top clamping of the wagons] **There shall be metal to metal contact between the side support beam and the side stanchions of the wagon** i.e. no rubber pad or

any other alternative, shall be provided on the contact face of the side support beam

- d) The side support beam shall be moveable type, the movement being done by hydraulic arrangement. (No external or moveable counter weights should be used with the side support beam) Facility of forward/ backward movement should exist, such that it should be able to move & touch the wagon without applying any pressure on the wagon side-wall. At this position it should get locked and the tilting operation can begin. At the end of the tipping cycle, the side support should return to its home position, so that the next wagon can be positioned on the tippler Movement of the side support should be controlled & the speed should be crawling just before making contact with the wagon sidewall.
- e) Pressure gauge/s should be mounted, at easily accessible location, for reading the hydraulic pressure of the side support hydraulic arrangement.

**3.0 Safety requirements** – Safety requirements for tippers, divided into the following three stages, construction stage shall be followed as under:

### **3.1 Construction stage**

- a. The design of the tippler shall avoid, as far as possible, any spillage of the material handled by the wagons.
- b. Devices shall be built-in to prevent any over run of the wagons in either direction.
- c. The tippler shall be designed so that the wagon is securely held in all operating positions.
- d. Automatic devices shall be provided to hold the tippers securely in any position in the event of failure of the drive unit.
- e. All tippers shall have means to limit the angle of tipping.
- f. Arrangement shall be made on tippers to prevent feet being trapped between the platform and the base of the tippler.
- g. Whenever possible mechanical or electrical devices shall be built-in to ensure that all the conditions allowing wagon tipping are coordinated.
- h. Additionally, a device shall be provided to prevent an empty wagon from being released until the tippler is back in original position.
- i. A device shall be provided to prevent the entry of a non-scheduled wagon into a tippler. Sharp edges and corners in all working spaces shall be avoided.
- k. The parts projecting into working spaces shall be as small as possible.

- l. All the frequently used lubrication points shall be accessible without it being necessary to remove the guards.
- m. It is recommended that equipment shall be so designed that maintenance and cleaning is facilitated.
- n. Fully integrated controls should be provided for wagon positioning system, wagon holding devices and wagon tippler. The controls should be interlocked so that there is no chance of accident due to error in sequence of operation.

#### 4.0 Positioning system for wagon

Wagon tippers shall be provided with side arm charger for positioning of wagons on the tippers, such that

- a. Side arm charger should be of sufficient capacity, depending on whether complete train or some wagons are to be moved / positioned. **There should be some positive system for centering of wagon on the tippler table.**
- b. Drive unit for the side arm charger should be of positive type e.g. rack & pinion, so that sudden jerks/slippages are avoided. Suitable technology should be used, so that the wagon can be moved at slow speeds for placement on tippler table e.g. Low speed hydraulic motors, Variable frequency AC motors or thyristor controlled DC motors (through epicyclical reduction gearing), etc.
- c. Charger should be able to slow down to creeping speed just before the final positioning

#### 5.0 Wagon & Train holding devices

##### 5.1 Wheel grippers

- a. **These are mandatory** & should be located on the tippler table, to prevent inadvertent motion of the wagons during tipping operation.
- b. These should be so designed that balanced pressure is applied on both sides of the wheel rim. It should have a floating arrangement so as to ensure that force on each gripper is same and should have some lateral float so that it can take a new position in case of variation in wheel gauge. Wheel grippers should be free from serrations or any such provision on its holding face. Wheel grippers should be made of soft material.

##### 5.2 Retractable wheel chocks

- a. **These are mandatory** & should be fitted at the in-haul & out –haul tracks, to prevent accidental rolling of the wagons on the tippler table.

- b. They should be so designed that flange of the wheel is not contacted while blocking tread of the wheel. Shape of the chock should take into account the wheel incline, so that a line contact is made with the wheel.

## 6.0 Check sheet for joint inspection

Check sheet for the six monthly joint inspection of the tippers to be conducted by DME/ Sr.DME (C&W) of the concerned division or his authorised representative and representative of the siding owner, as per Railway Board letter No.98/M(N)/951/12 dated 27.11.02, is as follows:

SN	Item		Check	Remarks
1	End frame platform side beam	(i) (ii)	Steel work to be examined for damage or defects. Check & record the gap between the side beam and the wagon side stanchion, during tipping operation.	
2	Drive gear	(i) (ii)	Check proper matching of rack and pinion tooth & tooth wear . Check whether coupling gives jerk during rotation. The tipping operation should be smooth & without any jerks	
3	Top hydraulic clamp	(i) (ii) (iii) (iv) (v) (vi)	Check the level of clamp pad. Whether sitting properly or not. Check the condition & thickness of clamp pad (thickness should not be less than 50 mm) Check the smoothness of clamp movement Check for provision of indicators on the tippler table for all types of wagon stock, which are likely to be tipped on the tippler. This is to ensure that wagons are placed on the tippler table in such a manner that the top clamping pads position is near the side stanchions. Force exerted by the top clamps should not exceed 1.5t per clamp pad. Check & record the value. Check for provision of a wagon bogie spring relief mechanism in the top clamp locks for permitting release of bogie springs.	

4	Rail table of wagon tippler	(i)	Check the level and alignment of rail. The level of track on tippler table and that of approach rails should be the same so that the wagons do not experience any jerk during in-haul and out-haul	
5	Limit switches	(i)	Check for proper function	
6	In haul & out haul stop linkage	(i) (ii)	Check satisfactory working of stop Movement. Check the gradient on the outhaul side.	
7	Side arm charger*	(i) (ii) (iii) (iv) (v)	Check damage / defects of steel work. Check proper matching of drive pinion & rack & tooth wear. Check the smooth movement and final position of arm hoist. Check the proper tightening of fastener & condition of track. Check for proper functioning of limit switches & proximity switches	
8	Damages to wagons.	(i)	Damages during tipping & post tipping damages: <ul style="list-style-type: none"> <li>• Dents/nick on the side stanchions, top copings, wagon body, etc</li> <li>• Displacement of bogie pivot or suspension springs</li> <li>• Damages to air brake pipes</li> <li>• Axle box adopter shifting</li> <li>• Coupler damages</li> <li>• Any other</li> </ul>	

**\*Note:** (1) There should not be any loose shunting of the wagons. In-haul and out-haul arrangements consisting of side arm charger should be used for placement and removal of wagon on tippler table. The practice of shunting empty wagon after tipping by rake of loaded wagons is not acceptable as it results into large scale damages to CBC and bogies.

**Representative of the  
Siding owner**

**Sr DME (C&W) /DME  
or  
Authorised representative**



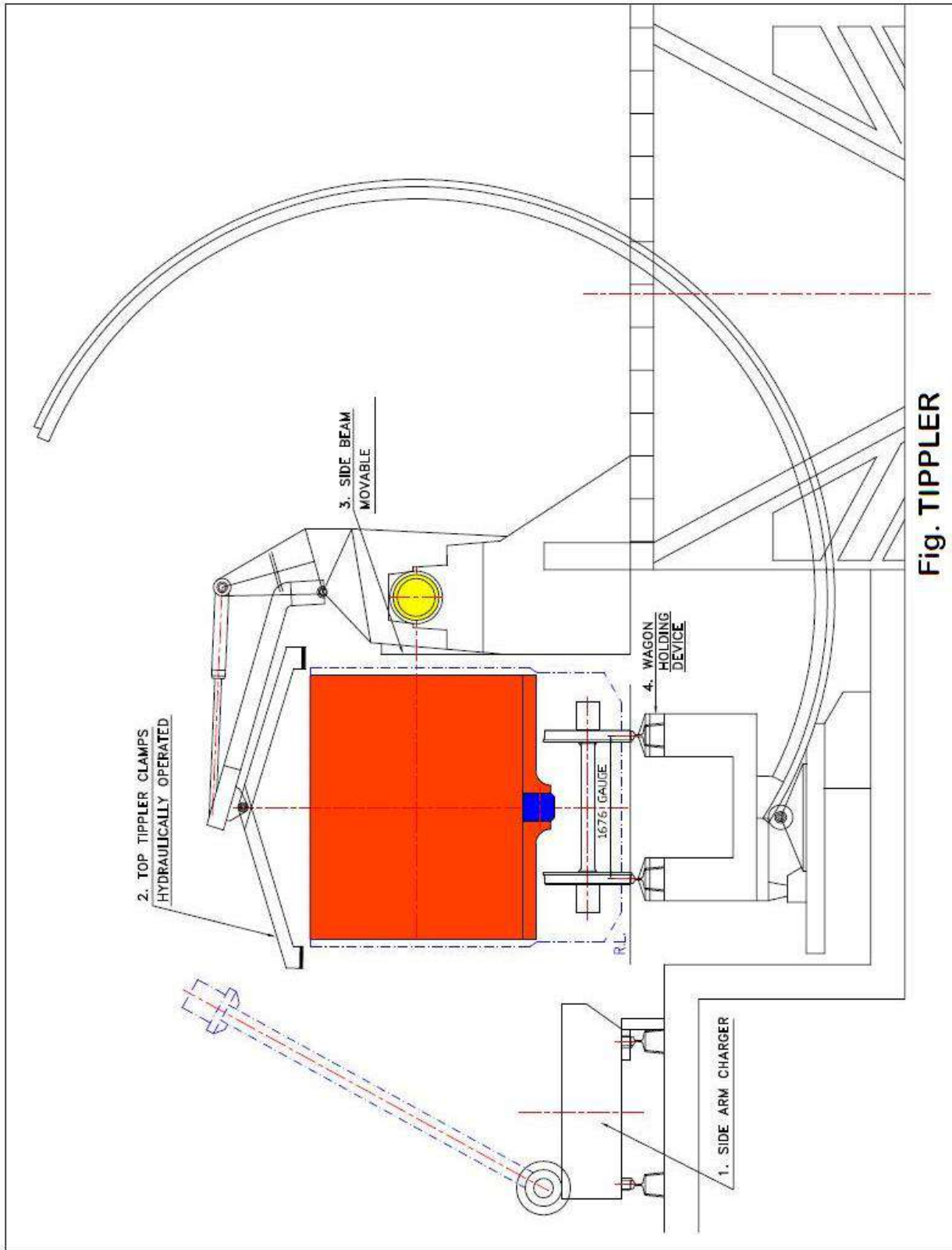


Fig. TIPPLER

**APPENDIX “II”**

**LIST OF IMPORTANT MODIFICATIONS TO BE CARRIED OUT ON FREIGHT  
STOCK**

(IRCA letter No. M/129/Policy/W dated 12.4.99 & Rly Bd. L. No. 98/M(N)/951/11 dt.6.4.99)

**I. WHEELS, AXLES, BEARINGS**

SN	Item Description	RDSO's Reference	To be done in			
			Sick line	ROH	POH	New Built
1.	Adoption of worn wheel profile for all BG wheels	MW/CWSC/58 dt.18.3.92	YES	YES	YES	YES
2.	Additional Intermediate Profile for wagon wheel.	RDSO letter no. MW/WA/GENL. Dated 13/15.01.2010	----	Yes	Yes	----
3.	Stamping of Overhauling date of CTRB on Backing Ring	RDSO letter no. MW/WA/GENL Dated 26.04.2012	----	----	Yes	----
4.	Non Use of Seal Wears Rings with vent holes	1. RDSO letter no. MW.RB.GENL. Dated 15/18.06.2012 2. RDSO letter no. MW/RB/BOXN Dated 08/12.08.2002	----	----	Yes	----
5.	Non Use of Backing Rings with Vent holes	1. RDSO letter no. MW/RB/BOXN Dated 20.12.1993 2. RDSO letter no. MW/RB/BOXN Dated 02.06.1995	----	----	Yes	----
6.	Phasing out of wheels having Sprag Holes from freight stock.	Railway Board's letter no. 2000/M (N)/960/1/Pt Dated 03.09.2008	----	Yes	Yes	----

**II. WAGON SUPER STRUCTURE AND BRAKE RIGGING**

1.	Strengthening of horizontal lever support (large on BOXN/BCNA wagons)	MW/BOXN/MAINT/d t.24.1.94	NO	YES	YES	YES
2.	Provision of anti rotation lug on empty tie rod coupling nut of BOXN/BCN wagons	MW/BOXN/MAINT/d t.15.1.94	YES	YES	YES	YES
3.	Provision of stiffener angle on axle guard of BVZC wagon	MW/CWSC/Secretaria t dt. 23.11.93 & 28.2.94	NO	NO	YES	YES
4.	Increase in the diameter of control rod from 28 to 32 mm of IRSA-600 Slack Adjuster	MW/SLA dt 23/29.12.93 & 10.5.94	NO	YES	YES	YES
5.	Provision of side bracket with link on BRH/BRN wagons to facilitate securing of steel plant consignment to wagon body	MW/ACT/BG dt. 27.5.94	NO	YES	YES	YES

SN	Item Description	RDSO's Reference	To be done in			
			Sick line	ROH	POH	New Built
6.	Modification to empty/load spindle bracket	MW/BTPN dt. 1.11.94	NO	NO	YES	YES
7.	Provision of extra roller type pull rod supports as per drg. WD-90016-S/1 Alt 12		NO	YES	YES	Not under manufacture
8.	Underframe strengthening of all welded BRN wagons	MW/BRN dt 12.12.98	NO	NO	YES	Not under manufacture
9.	Modification of existing door hold stiffener of BOBRN	MW/DOM/BOBR dt. 14.6.90	NO	YES	YES	YES
10.	Modification to anchoring tee joint on BTPN wagons	MW/BTPN dt.24/26.8.98	NO	NO	YES	NA

### III. COUPLER & DRAFT GEARS

1.	Fitment of modified striker casting wear plate in CBC	MW/CPL/BG/HT dt.6.1.88	NO	NO	YES	YES
----	-------------------------------------------------------	------------------------	----	----	-----	-----

### IV. AIR BRAKE SYSTEM

1.	Standardisation of isolating handle cock on DV	MW/APB/TP/M dt.27.9.88	NO	YES	YES	YES
2.	Modification to filtering arrangement of C3W DV of SCL	MW/APB/TP/M dt.24.11.88	NO	YES	YES	YES
3.	Provision of additional APD to DV	MW/APB/TP/M dt.1/6-5-92	NO	YES	YES	YES
4.	Modification to quick release valve of DV of Escorts make	MW/APB/TP/M dt.3/9-7-92	NO	YES	YES	YES
5.	Strengthening of APD for DV	MW/APB/TP/M dt.15.7.92	NO	NO	YES	YES
6.	Modification to the piping of BVZC wagon for fitment of quick coupling and detachable pressure gauge	MW/APB/TP/M dt.3/6-12-93	NO	YES	YES	YES
7.	Modification to hose coupling support	MW/APB 8/10-4-94	NO	YES	YES	YES
8.	Modification to the locking arrangement of barrel with leader nut casing of DRV2-600	MW/SLA dt. 20/21-7-88	NO	YES	YES	YES

## APPENDIX –III

## WAGON MANUFACTURERS AND WORKSHOPS

## A. WAGON MANUFACTURERS (As on March 2013)

1.	M/s Burnstandard Company Limited (Howrah Works), 20 – 22, Nityadhan Mukherjee Road, Howrah – 711 101
2.	M/s Burnstandard Company Limited (Burnpur Works), Burnpur, Burdhan – 713 325
3.	M/s Braithwaite & Company Limited, 5, Hide Road, Kolkata – 700 043
4.	M/s Bharat Wagon & Engineering Company Limited, Mokama – 803 302
5.	M/s Bharat Wagon & Engineering Company Limited, Post Box No. 61, Near Railway Station, Muzzafarpur – 842 001
6.	M/s Bridge & Roof Company (India) Limited, 427/1, Grand Trunk Road, Howrah – 711 101
7	M/s Texmaco Limited, 9/1, Birla Building, Sir R.N.Mukherjee Road, Kolkata – 700 001
8	M/s Titagarh Wagon Limited, “Premlata” 4th Floor, 39, Shakespeare Sarani, Kolkata – 700 017
9	M/s HEI Limited, Mody Building, 27, Sir R.N.Mukherjee Road, Kolkata – 700 001
10	M/s Besco Limited (Wagon Division), 8, Anil Maitra Road, Ballygunge, Kolkata – 700 019
11	M/s Modern Industries, G T Road, Sahibabad, Ghaziabad – 201 005
12	M/s Jessop & Co Ltd, 21 & 22, Jessore Road, Dum Dum, Kolkata – 700 028
13	M/s Jupiter Wagons Limited, 11, Satyen Dutta Road, Kolkata – 700 029
14	M/s Cimmco Limited, “Premlata” 4th Floor, 39, Shakespeare Sarani, Kolkata – 700 017
15	M/s Besco Limited (Foundry Division), “Poonam” 7th Floor, 5/2, Russell Street, Kolkata – 700 071
16	M/s Jindal Rail Infrastructure Ltd, NH – 8, Near Karjan Arts & Commerce College, Post & Taluka – Karjan, District: Vadodara – 391 440

## B. RAILWAY REPAIR WORKSHOPS

Every workshop has been allotted with five digit code. The first two digits will indicate the Railway in which the workshop is situated. The third digit will indicate the type of workshop and the fourth and fifth digit will indicate the individual number of the workshop.

*The codes allotted to the Railways are as follows;*

Name of the Railway	Code
1. Central Railway	01
2. Eastern Railway	02
3. Northern Railway	03
4. North Eastern Railway	04
5. Northeast Frontier Railway	05

Name of the Railway	Code
6. Southern Railway	06
7. South Eastern Railway	07
8. Western Railway	08
9. South Central Railway	09
10. East Central Railway	10
11. North Western Railway	11
12. East Coast Railway	12
13. North Central Railway	13
14. South East Central Railway	14
15. South Western Railway	15
16. West Central Railway	16

For the type of workshops, the following codification will be made use of;

Type of workshop	Code
1. Loco workshops	1
2. Carriage and Wagon workshops	2
3. Loco Carriage & Wagon workshops	3
4. Wagon ROH depots and Repacking depots	4

Accordingly, the following is the codification for various workshops;

Railway	S. No.	Name of Workshop	Code
Central 01.	1	Parel	01101
	2	Matunga	01201
	3	Kurduwadi	01301
Eastern 02.	4	Jalapur	02101
	5	Kancharapara (Loco)	02102
	6	Kancharapara (C&W)	02201
	7	Liluah	02202
Northern 03	8	Charbagh	03101
	9	Amritsar	03102
	10	Alambagh	03201
	11	Jagadhri	03202
	12	Kalka	03203
North Eastern 04.	13	Gorakhpur	04301
	14	Izatnagar	04302
Northeast Frontier 05.	15	New Bongaigaon	05201
	16	Dibrugarh	05301
	17	Tindharia	05302
Southern 06	18	Perambur (Loco)	06101
	19	Perambur (C&W)	06201
	20	Golden Rock	06301
South Eastern 07.	21	Kharagpur	07301
Western 08.	22	Dahod	08301
	23	Parel & MX	08201

Railway	S. No.	Name of Workshop	Code
	24	Junagarh	08202
	25	Pratapnagar	08302
	26	Bhavnagar	08203
South Central 09.	27	Guntapalli	09201
	28	Tirupati	09202
	29	Lalaguda	09203
East Central 10	30	Samastipur	10201
North Western 11	31	Ajmer (Loco)	11301
	32	Ajmer (C&W)	11201
	33	Jodhpur	11202
	34	Bikaner	11203
East Coast 12	35	Mancheswar	12201
North Central 13	36	Jhansi	13201
South East Central 14	37	Raipur	14201
	38	Nagpur	14301
South Western 15	39	Mysore	15201
	40	Hubli	15202
West Central 16	41	Bhopal	16201
	42	Kota	16202

### C. WAGON ROH DEPOTS:

Railway	S.No.	Depot	Code
Central Railway	1	CLA	01401
	2	DD	01402
	3	BSL	01403
	4	AQ	01404
Eastern Railway	1	CP	02401
	2	UDL	02402
	3	BGB	02403
	4	NH	02404
Northern Railway	1	UMB	03401
	2	KJGY	03402
	3	TKD	03403
	4	MB	03404
Northeast Frontier Railway	1	NJP	05401
	2	NBQ	05402
	3	NGC	05403
Southern Railway	1	JTJ	06401
	2	IPN	06402
	3	TNPM	06403
South Eastern Railway	1	BKSC	07401
	2	NMP	07402
	3	BNDM	07403
	4	TATA	07404
	5	DPS	07405
Western Railway	1	VTA	08401

<b>Railway</b>	<b>S.No.</b>	<b>Depot</b>	<b>Code</b>
	2	BRCY	08402
	3	SBI	08403
	4	RTM	08404
South Central Railway	1	GY	09401
	2	RDM	09402
	3	BZA	09403
	5	BPA	09405
East Central Railway	1	MGS	10401
	2	BRWD	10402
	3	PEH	10403
	4	GHZ	10404
East Coast Railway	1	VSKP	12401
	2	VSKP/OEC	12402
	3	VSPS	12403
	4	ANGL	12404
North Central Railway	1	GMC	13401
	2	JHS	13402
	3	BAD	13403
South East Central Railway	1	BIA	14401
	2	BIA(PP YARD)	14402
	3	BSP	14403
	4	DRZ	14404
South Western Railway	1	SGWF	15401
	2	MRJ	15402
	3	UBL	15403
	4	HPT	15404
West Central Railway	1	NKJ	16401
	2	STA	16402
	3	KTT	16403
	4	ET	16404



Appendix-IV

BRANDING DETAILS ON WHEEL AND AXLE

**STAMPING PARTICULARS**

1	MANUFACTURER'S CODE
2	YEAR OF MANUFACTURE
3	CONSECUTIVE No.
4	BATCH No.
5	INSPECTOR'S APPROVAL STAMP
6	'UT' FOR ULTRASONIC TESTING
7	MANUFACTURER'S/WORKSHOP'S CODE
8	MONTH AND YEAR OF ASSEMBLY
9	PRESSING ON PRESSURE IN TONNES

**PCD OF STAMPING OF DIFFERENT WHEELS**

TYPE OF WHEEL	PCD OF STAMPING ON RIM
COACHING	788 mm
W/MC-0-2-301	788 mm
T-0-2-622	788 mm
W/MC-1860	788 mm
MG/T-0-1-004	610 mm
WAGON	870 mm
W/MC-4764	760 mm
W/MC-4771	760 mm
WC-88025/S-8	830 mm
WC-88025/S-9	960 mm
CONTAINER FLAT	755 mm
CONTR.-9404-S/13	
SOLID WHEEL FOR EMU	842 mm (FOR MC)
SI-K4004	832 mm (FOR TO)

**NOTE:**

- WHEEL DETAILS**
  - .1 TO BE HOT/COLD STAMPED OR MARKED BY ELECTRIC ETCHING IN 10 mm LETTERS ON OUTER FACE OF THE RIM OF ROUGH TURNED OR FINISH TURNED WHEELS.
  - .2 FOR LHB COACH WHEELS, STAMPING SHOULD BE DONE ON OUTER FACE OF THE HUB. PARTICULARS OF S.No. 1 TO 4 SHALL ALSO BE STAMPED ON OUTER HUB FILLET AT LOCATION MARKED AS 'X', FOR EASY IDENTIFICATION IN ASSEMBLED CONDITION.
- WHEEL CENTRE DETAILS**
  - .1 TO BE COLD STAMPED OR MARKED BY ELECTRIC ETCHING IN 10 mm LETTERS AT THE HATCHED LOCATIONS ON OUTER FACE OF THE HUB.
- AXLE DETAILS**
  - .1 TO BE STAMPED COLD OR MARKED BY ELECTRIC ETCHING ON BOTH ENDS IN 5 mm LETTERS IN CASE OF ROUGH TURNED OR FINISHED AXLES.
  - .2 TO BE STAMPED IN 10 mm LETTERS IN CASE AXLES ARE SUPPLIED IN AS FORGED CONDITION.
- ASSEMBLY DETAILS**
  - TO BE STAMPED COLD OR MARKED BY ELECTRIC ETCHING IN 10 mm LETTERS ON THE OUTER FACE OF THE WHEEL/WHEEL CENTRE HUB.
- IT IS MANDATORY TO STAMP THE RESPECTIVE MARKINGS AT THE LOCATIONS INDICATED ABOVE.

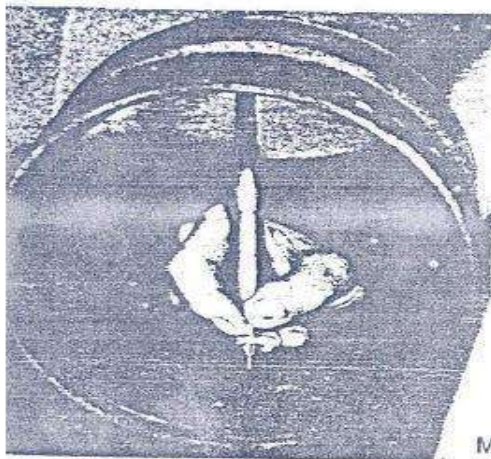
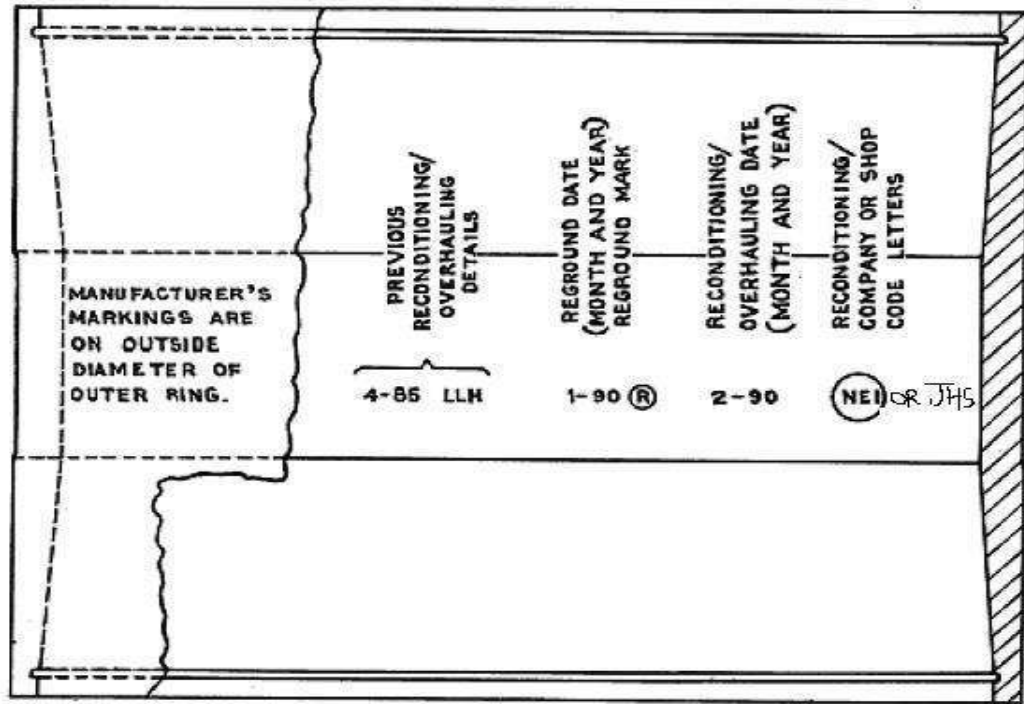
⑦	SS/21/06 ON LHB COACH WHEELS ADDED AND NOTE 1,2 MODIFIED.	12/09	SUPERSEDED BY:
⑥	SS/19/09 RADIUS AT END VIEWS OF THE AXLE CHANGED FROM 18R TO 23R.	10/09	SUPERSEDED:
⑤	SS/01/06 DRAWING REVISED	1/06	SCALE P
④	SS/13/03 DRAWING REVISED	3/03	C G.V.RAMAN
③	SS/3/02 DRAWING REVISED	2/02	D BANUJAY
②	CD/17/99 DRAWING REVISED	8/99	T ---
①	CD/6/97 DRAWING REVISED	9/97	J.S. ---
ALT. ITEM	DESCRIPTION	DATE	R.D.S.O. [c]
			B.G.

**BRANDING DETAILS ON WHEEL & AXLE SKETCH-92114**



APPENDIX- IV-A

Bearing/CTRB marking



OUTER RING MARKING

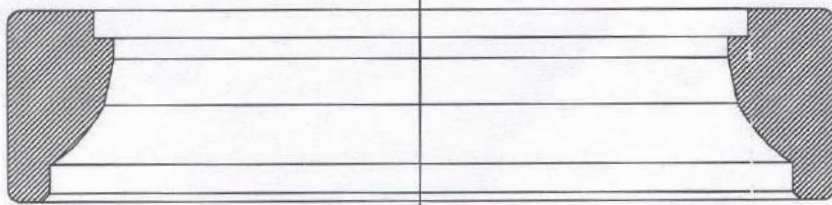
NOTE: Reconditioning and remanufacturing markings (encircled R for regrinding ) must be on the inner diameter of the outer ring on the straight portion in the center between the raceways. Caution must be used to avoid nicking or damaging the raceway surfaces. Mark with a suitable scribing tool. Electric etching or steel stamping is not permitted.

Method of Permanently Marking Reconditioned Roller Bearing Parts (Mandatory)

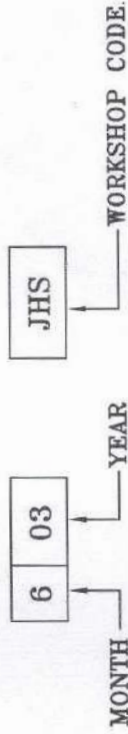
**Note:** bearing that have been serviced during POH or otherwise because of rediscing, hot box, accident etc have to be permanently and legibly marked on the Cup/Outer ring inner diameter on the straight portion in the centre between the raceways as shown in the above Figure.

APPENDIX -IV "B"

MARKING OF OVERHAULING PARTICULARS ON BACKING RING OF CTRB



MARKING DETAILS



① STAMPING SHALL BE LEGIBLE AND DONE IN 20 mm LETTERS AND NUMBERS

MARKING LOCATION.

BACKING RING

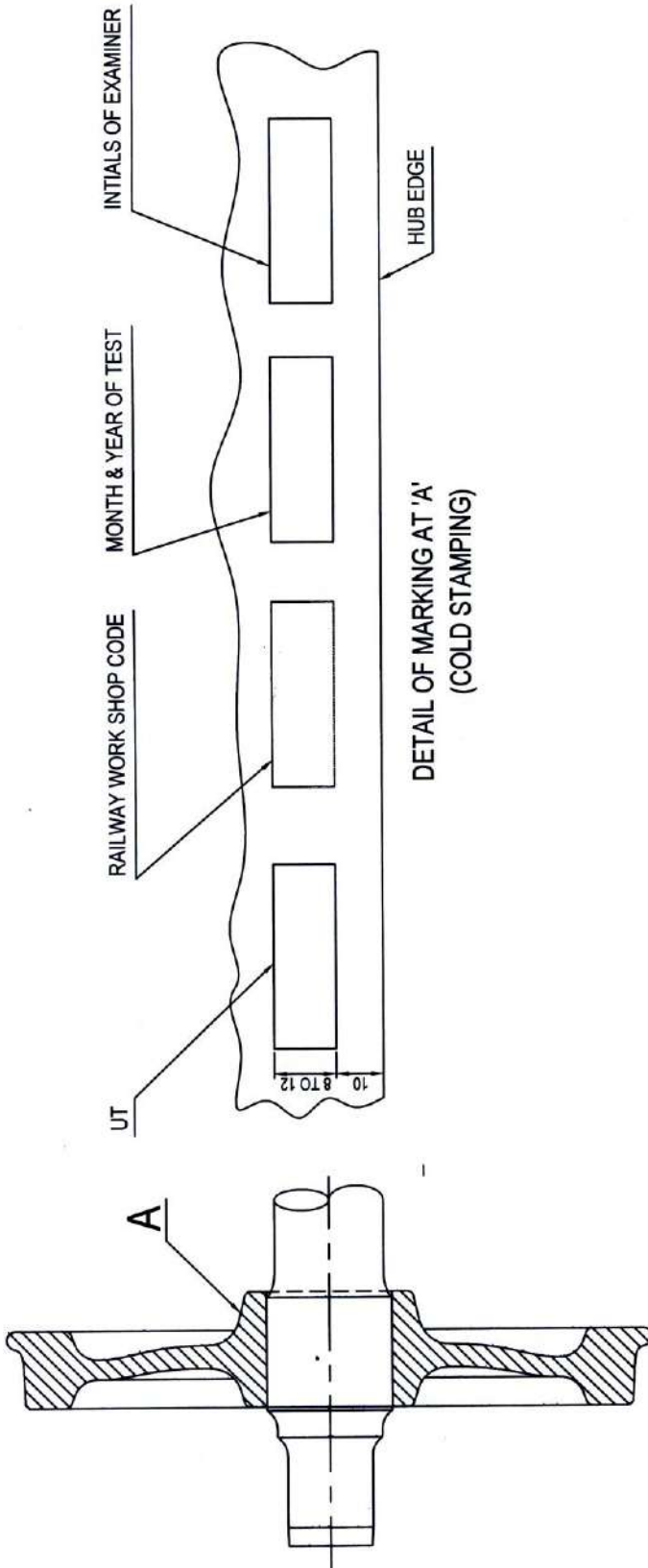
SURFACE ROUGHNESS VALUE TO IS:3073	Gr. NUMBER	N1	N2	N3	N4	N5	N6	N7	N8	N9	N10	N11	N12
	Ra	0.025	0.05	0.1	0.2	0.4	0.8	1.5	3.2	6.3	12.5	25	50
	SYMBOL	√	√	√	√	√	√	√	√	√	√	√	√

①	WD-14003	ALT.	DATE	ASSEMBLY DRG.
	-		03/14	
	WD-14003			
1)	TITLE BLOCK DESCRIPTION MOVED			
2)	MARKING NOTE MOVED.			

SUPERSEDED BY		DATE	
SCALE	FIGURED	16/73	16/73
CHECKED	DATE	16/73	16/73
DRAWN	DATE	16/2008	16/2008
TRACED	DATE		
U.S. NO.	DATE		
B.G.		R.D.S.O. GROUP	
[W]		WD-03034/S-1	
MARKING OF OVERHAULING PARTICULARS ON BACKING RING OF CTRB			

APPENDIX- IV-C

MARKING FOR ULTRASONIC TESTING OF AXLES  
(TO BE DONE ON WHEEL HUB)



NOTE:

1. 'UT' INDICATES ULTRASONIC TESTING OF AXLES
2. THE MARKING SHALL BE STAMPED COLD ON THE INNER HUB FILLET AS SHOWN AT 'A' AFTER THE SURFACE IS GROUND PROPERLY
3. THE EXAMINING WORKSHOPS SHALL MAINTAIN ALL THE PARTICULARS OF AXLES TESTED VIZ I.R PART NUMBER, CONTRACT NUMBER, CAST AND CONSECUTIVE NUMBERS, MANUFACTURERS INITIALS AND YEAR OF MANUFACTURE IN REGISTER PROPERLY MAINTAINED BY THEM.

**APPENDIX - V****LIST OF MUST CHANGE ITEMS IN FREIGHT  
STOCK DURING POH AND ROH**

(Railway Board's Letter No. 2003/M(N)/951/22 dated 16-01-2013)

**ITEMS TO BE REPLACED DURING ROH**

<b>Sr. No.</b>	<b>Description of item</b>	<b>Justification for replacement</b>
<b>A</b>	<b>CASNUB BOGIE</b>	
A-1	SF Key nut bolt with washer	During dismantling of wheel from bogie, it is necessary to cut the bolt since it is tack welded with nut. Therefore the committee recommends 100% replacement of this item during ROH.
A-2	Split Pin 12 x 110 mm	The split pins of Brake Shoe key are being changed 100% in some depots as they are getting distorted /damaged while taking out the brake blocks. Hence 100 % replacement is recommended during ROH.
A-3	CTRB Locking plate	The Locking plates are being changed on 100% basis. While carrying out the UST of Wheel sets, the locking plates are to be removed and while doing so, tabs are getting damaged or broken. Hence 100 % replacement is recommended during ROH.
<b>B</b>	<b>CBC</b>	
B-1	Striker casting Wear Plate	This item is subjected to wear in service as it comes in contact with CBC Shank. Wear Plate. Some ROH depots are replacing the item to the extent of 100 %. The worn out component will have serious impact on uncoupling of CBCs and it will also damage CBC shank; it will cause ovality on the top portion of Yoke Pin hole. Therefore the committee recommends 100% replacement of this item during ROH.
<b>C</b>	<b>Air Brake System</b>	
C-1	Dirt Collector Filter	This is basically a non-metallic strainer and of a small value. At present depots are changing on condition basis and there is an apprehension that dirt collectors are not at all opened in depots during ROH. There are many cases of DV malfunctioning and subsequent brake bindings in service and the filter is playing a major role. Therefore the committee recommends 100% replacement of this item during ROH so that it will be compulsory on the part of the depot to open the Dirt Collector.

C-2	Dirt Collector Washer ('O' Ring)	These are the small value rubber items perishable in nature and getting damaged while opening the assemblies. Therefore the committee recommends 100% replacement of this item during ROH.
C-3	Rubber gaskets	
C-4	MU washers	
C-5	AR Drain Plug leather washer	These items are perishable in nature getting damaged while opening the assemblies. Therefore the committee recommends 100% replacement of this item during ROH
C-6	BC Drain Plug leather washer	
<b>D</b>	<b>Tank wagons</b>	
D-1	Filling Pipe Joint Ring (BTPN)	These are the rubber items perishable in nature and getting damaged while opening the assemblies. Therefore the committee recommends 100% replacement of this item during ROH.
D-2	Man Hole Cover Sealing Ring.	

**ITEMS TO BE REPLACED DURING POH:**

Sr. No.	Description of item	Justification for replacement
<b>A</b>	<b>CASNUB BOGIE</b>	
<b>A-I</b>	<b>Side Frame</b>	
1.	Pedestal Jaw Liners	These items are subjected to wear in service as they are continuously in contact with adaptor and not expected to last beyond one POH. The liners of suitable thickness are Required to be welded. Therefore the committee recommends 100% replacement of these items during POH. Committee also recommends that no weld metal deposit should be done on the pedestal jaw surfaces to maintain the clearances as no machining is done after welding. RDSO may explore the possibility of liners in original design. The smoothness of the surface is primarily important.
2.	SF Key nut bolt with washer	During dismantling of wheel from bogie, it is necessary to cut the bolt since it is tack welded with nut. Therefore the committee recommends 100% replacement of this item during POH.
<b>A-2</b>	<b>Bolster</b>	
1	Land surface liner	These items are subjected to wear in service as they are continuously in contact with adaptor and expected to last from POH to POH. The liners of suitable thickness are required to be welded. Therefore the committee recommends 100% replacement of this item during POH.
2	Pocket slope liner	
3.	Rotation stop lug liner	

<b>A-3</b>	<b>Bogie Brake Gear</b>	
1	Split Pin 12 x 110 mm	The split pins of Brake Shoe key are being changed 100% in some depots as they are getting distorted/damaged while taking out the brake blocks. Hence 100 % replacement is recommended during POH.
<b>A-4</b>	<b>CTRB Locking plate</b>	The Locking plates are being changed on 100% basis. While carrying out UST of the Wheel sets, the locking plates are to be removed and while doing so, tabs are getting damaged or broken. Hence 100 % replacement is recommended during POH.
<b>A-5</b>	<b>Elastomeric pads</b>	It has been observed that many workshops are replacing this item to the extent of 100%. Being a rubber component, committee recommends 100% replacement of this item during POH. However, the serviceable EM Pads shall be given to divisions for replacement during the course of train examination.
<b>B</b>	<b>Draw and Buffing Gear Assembly</b>	
B-1	Knuckle	Knuckle is subjected to wear on Nose, Pulling lug area. Some workshops are changing on 100% basis and released serviceable material is given to divisions. Knuckles are playing very important role in coupling gear. In the present spurt of train parting I uncoupling cases Knuckles might be playing a vital role. Upgraded couplers are being developed by RDSO as per WD70-BD-10. The committee therefore recommends one time replacement of indigenous knuckles with the upgraded knuckles as per WD- 70-BD-10. However, serviceable knuckles shall be given to divisions for replacement during train examination.
B-2	CBC Lock	Lock is subjected to wear on contact area corresponding to Knuckle pulling lug and curved surface. Committee has observed that majority of the uncoupling cases are on account of worn out Locks. Upgraded couplers are being developed by RDSO as per WD-70-BD-10. The committee therefore recommends one time replacement of indigenous CBC locks with the upgraded CBC locks as per WD- 70-BD-10. However, serviceable locks shall be given to divisions for replacement during train examination.

B-3	Rotary Lock Lift Assembly	Mostly, the Anti-Creep Lug of Lock Lifter Assembly is found in worn condition. Moreover, the alignment is disturbed due to riveting became loose in service. Upgraded couplers are being developed by RDSO as per WD-70-BD-10. The committee therefore recommends one time replacement of indigenous lock lift assembly with the upgraded lock lift assembly as per WD-70:BD-10. However, serviceable assemblies shall be given to divisions for replacement during train examination.
B-4	Bearing Piece	The committee observed that consumption of this item between workshops to workshop varies from 3% to 33%. The item is subjected to wear in service; the slot (17.5 mm x 17.5 mm) of bearing piece becomes worn out in service and not holding the Operating Handle in position. As a result the operating handle along with Rotary Lock Lift Assembly gets displaced from its position thereby causing uncoupling of CBC. The item is not expected to last beyond one POH. The committee therefore recommends 100% replacement of this item. However, serviceable bearing pieces shall be given to divisions for replacement during train examination.
B-5	Yoke Pin support plate liner	This item is subjected to wear particularly due to interaction of Yoke Pin's vertical movement. The pin makes a dent mark on the liner which is dangerous which restricts the movement of the yoke pin resulting in the breakage of Support plate rivets. The item is not expected to last beyond one POH cycle. The committee therefore recommends 100% replacement of this item.
B-6	Shank Wear Plate	This item is subjected to wear in service as it comes in contact with CBC Shank Wear Plate. Some workshops are replacing the item to the extent of 70%. The worn out component will have serious impact on uncoupling of CBCs and it will also damage CBC shank. The life of the component is not expected beyond one POH cycle. Therefore the committee recommends 100% replacement of this item during POH.
B-7	Striker Casting Wear Plate	This item is subjected to wear in service as it comes in contact with CBC Shank. Some workshops are already replacing the item to the extent of 100%. The worn out component will have serious impact on uncoupling of CBCs. The life of the component is not expected beyond one POH cycle. Therefore the committee recommends 100% replacement of this item during POH.

<b>C</b>		<b>Air Brake System</b>
C-1	Dirt Collector Filter	This is basically a non-metallic strainer and of a small value item. At present workshops are changing on condition basis. There are many cases of DV malfunctioning in service and the filter is playing a major role. The life of the component is not expected beyond one POH cycle. Therefore the committee recommends 100% replacement of this item during POH.
C-2	Dirt Collector Rubber Washer ('O' Ring)	These are the rubber items perishable in nature and getting damaged while opening the assemblies. The life of the items is not expected beyond one POH cycle. Therefore the committee recommends 100% replacement of this item during POH.
C-3	Rubber gaskets	
C-4	Rubber Seals of Cut off Angle Cocks.	
C-5	MU washers	
C-6	Grip seals / Rubber washers	
C-7	AR Drain Plug leather washer	These are items perishable in nature and Getting damaged while opening the assemblies. Therefore the committee recommends 100% replacement of this item during POH.
C-8	BC Drain Plug leather washer	
C-9	BP Air Hose	This item is generally tested during POH for leakage and bulging at 10 Kg/cm <sup>2</sup> pressure and about 50% rejection is there. Moreover, there are large numbers of service failures. Some workshops are changing 100%. Being a Rubber item; it is not expected to last beyond one POH cycle. Therefore the committee recommends 100% replacement of this item during POH. However, serviceable hoses shall be given to divisions for replacement during train examination.
<b>D</b>		<b>Tank wagons</b>
D-1	Filling Pipe Joint Ring (BTPN)	These are the rubber items perishable in nature and getting damaged while opening the assemblies. Therefore the committee recommends 100% replacement of this item during POH.
D-2	Man Hole Cover Sealing Ring.	

**Note:** Zonal railways may review the consumption of items and further rationalize the AAC of the items at their ends.



## APPENDIX "VI"

# GUIDELINES FOR MAINTENANCE & REPAIR OF STAINLESS STEEL WAGONS



# GUIDELINES FOR MAINTENANCE & REPAIR OF STAINLESS STEEL WAGONS

## CONTENTS

<b>1. Introduction:-</b> .....	<b>3</b>
<b>2. Stainless Steel : The peculiarities:</b> .....	<b>3</b>
<b>3. Maintenance of SS Wagons : <i>An Overview</i></b> .....	<b>4</b>
<b>4. Facilities required for maintenance of Stainless steel Wagons:-</b> .....	<b>4</b>
<b>5. MAINTENANCE ACTIVITIES IN SS WAGONS.</b> .....	<b>5</b>
5.1 Inspection	
5.2 Cutting	
5.3 Straightening	
5.4 Replacement	
5.5 Welding	
<b>6. SURFACE PREPARATION &amp; PAINTING</b> .....	<b>13</b>

## **1. INTRODUCTION-:**

Corrosion is perhaps, the single biggest challenge that needs to be surmounted, to attain increased service life of Wagons. Continuous exposure to moisture, air & high temperature, repair practices resulting in localized heating, loading/ unloading practices resulting in damages to the employed surface protection& incorrect/ inadequate surface protection are the main causes of propagation of corrosion.

An effective means of tackling corrosion is by selecting corrosion-resistant raw material for fabrication of wagons. Such a selection, however, has, to consider, weldability, ease of fabrication, formability & availability of the chosen raw material besides the cost. Based on the above considerations, IR has introduced the use of Ferritic grade Stainless Steel (SS), to IRSM:44 specification, in BOXNHL & BCNHL wagons. Based on the experiences gained, IRSM:44, has also been introduced in rehab of BOXN wagons- BOXNR wagons.

The introduction of SS, has brought forth maintenance issues, related to cutting, welding or straightening of SS, patch repairs, attention to various types of similar and dissimilar joints between stainless steel, carbon steel and corten steel.

To understand, these maintenance issues, it is important to understand the inherent properties of SS & how it is different than the conventional MS, used hither-to in wagon fabrication.

## **2. STAINLESS STEEL: THE PECULIARITIES:**

The chemistry of Stainless steel differs from carbon steel by the amount of chromium present. The presence of Cr, promotes the development of an invisible, adherent and self-healing chromium-rich oxide surface film. Carbon steel rusts when exposed to air and moisture. This rust, essentially an iron oxide film is active and accelerates corrosion by forming more iron oxide. Stainless steels have sufficient amount of chromium present so that a passive film of chromium oxide forms on initial oxidation, which prevents further corrosion.

The tough chromium-oxide layer, also comes into play, during the repair/ cutting of SS. In conventional carbon steels, during, oxy-cutting the metal is first heated by the flame, and then an excess of oxygen is supplied. This causes an exothermic (heat generation) reaction which generates the heat necessary to melt the oxides formed, which are then removed from the cut by the velocity of the gas jet. In this process a rough surface is produced. Where as, stainless steels having a high level of Chromium (Cr) cannot be cut by simple oxy-cutting methods due to the refractory nature (very high melting point) of the Chrome Oxide which is formed as the top layer. Ferritic stainless steels are generally limited to service temperatures below 750°F (400°C) due to the formation of embrittling phases, which may also precipitate during welding. Primary concerns with welding ferritic grades are maintaining adequate toughness and ductility in the as-welded condition.

### 3. MAINTENANCE OF SS WAGONS: AN OVERVIEW

RDSO has introduced SS in the newly designed BOXNHL, BOXNLW, BOXNR & BCNHL wagons.

In constructional design, BOXNHL, BOXNR and BOXNLW wagon are similar to BOXN wagon and BCNHL wagon is similar to BCNA wagon. Hence, the maintenance and Repair procedure of these wagons shall be similar to BOXN/BCNA wagons. The procedure for attending to repairs in BOXN & BCNA are given in the Maintenance manual for Wagons Issued by CAMTECH.

However, since the wagon body and under frame of BOXNHL, BOXNLW, BOXNR & BCNHL wagons are made of higher grade steel i.e. IRSM-44 /IRS M-41 steel/CRF sections, the cutting, straightening, welding / repairing procedures are slightly different than plain carbon steel wagons.

Before elaborating on repair details, **it is important to understand that the SS wagon structural members, body panels& other components that form part of the wagon structure, when corroded/damaged, should necessarily be repaired or replaced with similar grade of steel only.**

### 4. FACILITIES REQUIRED FOR MAINTENANCE OF STAINLESS STEEL WAGONS:-

Reiterated below, for guidance, are recommended facilities (by CAMTECH) for effective maintenance of SS wagons:

S.No.	Item/Description	Freight Yard (maintaining 3 rakes/day)	Sick line (5 wagon/day)	ROH Depot./workshops (200 wagons/month)
1.	MIG/MAG Welding sets (400 Amp.)	02 Nos.	02 Nos.	03 Nos.
2.	DC Arc Welding Rectifier (600 Amp.)	02 Nos.	02 Nos.	03 Nos.
3.	Portable Air plasma cutting machine (Max. capacity 16 mm)	02 Nos.	02 Nos.	03 Nos.
4.	Consumables for Air Plasma M/C i.e. Torch tip, catalyst etc.	As per Requirement		
5.	Welding electrodes  For IRS M-44 to IRS M- 41 etc.	As per Requirement		

6.	Lock bolts of various sizes ( 3/8" to 7/8")	As per Requirement		
7.	Lock bolting Equipment	02 sets	02 sets	03 sets.
8.	Portable grinding Machine (only dedicated grinding wheels & disc should be used.)	03	03	05
9.	Stainless steel wire brushes	As per Requirement		
10	IRS M44 & IRS M41 plates/sheets & CRF sections as per wagon design drawing.	As per Requirement		

**Note:** The class of welding electrodes for different combinations of materials shall be as per RDSO specification No. G-72 latest revision.

## 5. MAINTENANCE ACTIVITIES IN SS WAGONS.

The maintenance of wagons mainly consist of the activities of Inspection, cutting, straightening, replacement, welding and finally painting. Brief details of these activities, with particular attention to be given for SS wagons, are enumerated below:

### 5.1 Inspection of Under frame and Body

The under frame members & body should be thoroughly inspected for locating cracks, bent/damaged, corroded members. A component that warrants repair should be repaired as per the defined procedure, in the wagon maintenance manual. In case a component/ sub-assembly/ structure is found to be corroded & is judged to be beyond repair, the same should be replaced. Essentially, the repair/ replacement should be done on condition basis.

***During Inspection of wagons, special/ particular attention should be paid to the below detailed vulnerable members and locations:***

- Sole bar, side wall stanchions, and floor plates.
- Head stock, corner angle and end stanchions.
- Top copings, and corner joints.
- Door locking brackets and hinges.
- Puncturing/damages of side/end sheets.
- Centre pivots, and center sill.

- Cracks in center sill, sole bar and cross members etc.
- Breakage/Failure of lock bolts.

**5.2 Cutting of IRSM-44:**

The IRSM-44 steel panels/plates/CRF sections shall be cut either by shearing machine or by plasma cutting machine but not by oxy-cutting.

*The guidelines for cutting of IRS M-44 are subdivided into the following sections:-*

**a. Guillotining**

- i) The guillotine is normally used for cutting steel up to 16 mm thick. The maximum capacity of the guillotine (used for mild steel shearing) should be downgraded by 30-40% for cutting IRS:M44 because of IRS:M44's greater shear strength, e.g. if maximum shear capacity is 16mm(mild steel) then the maximum shearing capacity will be 11mm for IRS:M44.
- ii) "Shear breaks" on the cut edge can be prevented by using well sharpened, correctly aligned and set blades especially for plates heavier than 8mm.
- iii) Burnish and burr heights increase with increasing blade dullness and blade gap and rollover tends to be excessive. This needs to be taken note of & suitable corrective/preventive action taken.
- iv) Shear break or splitting should not be confused with laminations as the former is a result of the shearing process parameters, while the latter is a material defect. Shear break is caused by excessive cutting speeds, blade clearance etc.

*The following guillotine clearance settings are given for guidance:-*

Plate Thickness (mm)	3	6	10
Clearance Settings (mm)	0.1	0.15	0.25

- v) The most suitable shear blades for cutting IRS:M44 and stainless steel are made of high carbon-high chromium tool steel. The blades must be kept sharp- a good test is to cut a piece of paper.
- vi) Good practice is to wipe the blade and hold down pads free of adherent mild steel particles prior to cutting IRS:M44. This will avoid mild steel contamination.
- vii) Where possible, shearing speeds should be reduced by up to 20%. This will prevent shear break of thick plates.

**b. Plasma cutting**

Due to high chromium content of IRS:M44 it cannot be cut with the conventional oxy-acetylene torch. Portable plasma cutting equipment with inbuilt liquid tank are also available which can be used for repair work.

- i) Plasma cutting and profiling of IRS:M44 is the fastest and most economic thermal cutting method available. Fast cutting speeds together with a clean smooth surface finish can be achieved. Due to the fast cutting speeds, the heat affected zone is very narrow, minimizing the effect on the properties of the material. Thin plates can be stack-cut. Any discoloration of the cut edge can easily be removed by grinding or by using a stainless steel wire brush. If no subsequent welding is undertaken, edge discoloration must be removed, followed by passivation.

## ii) Cutting Gases

At present, there are many makes of portable plasma cutting machines which are able to cut up to 16mm thick plate. These portable units make use of compressed air (300 – 500 KPa) rather than mixed plasma gases. These machines are light, (weighing not more than an oxy-acetylene set) economical and efficient. Consumable items are the torch tip and the catalyst.

For gauges in excess of 16mm, heavier mixed gas plasma cutting machines will have to be used. Oxygen – free nitrogen is the most economical cutting gas. Other gases which can be used include mixtures of argon and hydrogen or nitrogen and hydrogen. The secondary shielding gas can be one of numerous gases such as welding grade carbon dioxide which is inexpensive. Argon or argon-hydrogen mixtures are often used where a better, cleaner cut is required.

## c. Abrasive Cut – off Wheels

Abrasive disc cutting can be used for limited lengths of cut. Only dedicated discs should be used and suitable control of the storage of these must be exercised. Use can be made of water soluble oil for cooling/lubrication.

Aluminum oxide discs of the vitrified or resinoid bonded types are suitable. Zirconia silicon carbide discs are not recommended.

## d. Arc-Air Gouging

Arc-Air gouging is a suitable method of cutting provided the recommended settings are adhered to in order to produce acceptable cuts. All cut edges must be ground back (using dedicated grinding discs) to a depth of approximately 2mm to remove the heat affected zone before further fabrication. Areas not subsequently welded must be de-scaled and passivated.

## e. Powder Cutting

Ferrite powder injected into an oxy-acetylene flame can be used to cut IRS:M44, but the unsightly edges produced must be ground back approximately 2-4 mm using dedicated discs before further fabrication, to ensure that the plane edge is of an acceptable quality. Areas not subsequently welded must be de-scaled and passivated.

**f. Slitting**

After cutting on conventional slitting equipment, edge must be deburred. Slitting knives should be cleaned of all mild steel or other metal contamination before IRS:M44 is processed. Close control of blade clearance will ensure good edges. Blade clearances are as for guillotine settings.

**g. Cold Sawing**

Cold sawing is suitable provided a high feed rate is maintained to produce an acceptable cut. Cutting and cooling fluids (water soluble oil type) should be used for cutting thicker gauges.

High speed wavy tooth blades are recommended with up to 13 teeth/cm for light gauge material. The number of teeth per centimeter should be reduced as the gauge increases.

**h. Blanking and Punching**

These operations can be successfully carried out provided that tools and equipment used have sufficient strength and rigidity to account for the higher proof strength of IRS:M44. Clearance between the punch and the die is normally held to 5% of the metal thickness on a side i.e. 10% overall. Punches must be kept sharp, and where possible, the speed of operation should be reduced.

**i. Drilling**

High speed drills should be used on IRS:M44. It is advisable to have the web of the drill thinned as much as possible (up to 1/8 the drilling diameter) to eliminate excessive drilling temperatures caused by the friction generated at the bottom of the hole.

The included angle of the cutting edge should be  $\pm 120^\circ$ . The drills should be as short as possible to improve rigidity. A suitable cutting compound (sulphurized or chlorinated oil) should be used for drilling deep holes. Cooling of the drill cutting edge can be effected using a light water-soluble oil which will extend drill life. Drills should be backed out at regular intervals to relieve chip congestion.

**5.3 Straightening of IRSM-44:**

The wagon members which are bent/deformed can be straightened up to a certain extent. It is notable that IRS:M44 requires, greater bending capacity to straighten the steel members owing to its higher yield strength. As an approximation, the maximum capacity of the bending is reduced by 40% for bending IRS:M44 compared to mild steel. Also, IRS:M44 generally exhibits greater spring back than mild steel during bending. This should, hence, be compensated for, by slight over-bending, e.g. 5% on a  $90^\circ$  bend.

Use of hydraulically/ manually operated Tie screw pulling and hammering is recommended for bending /straightening wagon members. The members which are more than 5mm thick and are distorted/bend can be heated locally upto  $150^\circ\text{C}$  and straightened by hammering/pulling. However, heating of stainless steel members beyond  $150^\circ\text{C}$  should be avoided in view of change in chemistry of steel.



If members are badly distorted/bent and straightening is not possible, the members should be replaced with similar grade of materials, instead of attempting major repairs by heating/ straightening.

It is also recommended that in case severe bending of thicker plate sections, needs to be done, such bending operations should be carried out before welding operations, so as to avoid the possibility of heat affected zone cracking.

Edge cracks can be avoided by placing the cut face on the outside radius of the bend and the sheared face on the inside. This type of cracking can also be prevented by grinding the outside radius point of bending into a rounded profile. Thus, eliminating the natural stress concentration point.

#### **5.4 Replacement**

Heavily damaged members should be replaced with similar grade of steel with new members.

#### **5.5 Welding Procedure:-**

The main differences between welding stainless steel and mild steel are owing to differences in properties of SS in terms of coefficient of linear expansion, thermal conductivity, ductility etc. This affects the work hardening and shock absorption properties.

For stainless steel welding various welding processes can be used such as MIG, TIG, MMAW, Resistance welding and laser welding. However, the following issues, need to be considered in case of SS repairs:

##### **5.5.1 General Precautions in Welding of Stainless Steel**

- i. Since Stainless steel has high coefficient of thermal expansion and less heat conductivity, it is advised to use low welding currents in the recommended range and smaller gauge electrode to minimize heat input and reduce distortions.
- ii. Surface to be welded must be clean, dry and free from dirt, oxide film, oil, grease, paints etc.
- iii. Electrodes should be re-dried before use.
- iv. Always maintain short arc to minimize the loss of alloying elements.
- v. Avoid weaving and make stringer beads.
- vi. After finishing welding, lift electrode slowly and fill the crater before breaking the arc. This will avoid crater cracks.
- vii. Use stainless steel wire brush for cleaning welds.
- viii. Use electrode preferably with DC (+).

- ix. Every bead should be properly cleaned before further welding on it.
- x. Welding should be preferably carried out in flat position.
- xi. Correct electrode size, recommended current, arc length, travel speed and electrode angle must be followed.
- xii. Any defect like crack, blowhole etc. must be properly gouged out and re-welded.
- xiii. Do not strike arc adjacent to the weld.
- xiv. Tack the welded area correctly to ensure proper gap.
- xv. Proper welding sequence must be followed to reduce internal stresses and hence reduce warpage of structure.
- xvi. Always weld towards the free ends.

### **5.5.2 Weldability issues:**

- Grain growth in the HAZ and loss of toughness.
- Reducing the heat input is critical and no preheats should be given.
- Oxides formed during welding in the weld zone do not protect it from subsequent corrosion.
- Proper protection of the weld zone from atmosphere and subsequent cleaning after welding are important.
- Stringer beads to reduce the heat input.
- Maintaining interpass temperature below certain temperature (in multipass weld). Also, allow weld to cool between the passes and using copper chills.

### **5.5.3 Preparation prior to Welding:**

The following points should be considered before welding of IRSM:44 components.

- i. The area about 15 mm from each side of the weld zone should be properly be cleaned.
- ii. The weld area should be free from dust, dirt, grease, oil, paints etc. Any non-corrosive and suitable organic solvent (Kerosene oil, Benzene etc.) can be used for removing grease, oil & paints.
- iii. Only Stainless steel wire brushes should be used to remove tenacious layer of chromium oxide for better strength of joint.

- iv. No edge preparation is required, unless specifically mentioned in the drg, when welding up to thickness 3/16"(5 mm approx.). For higher thickness between 3/16" & 1/2" (5-12mm approx.) bevel preparation is necessary.

#### **5.5.4 Precautions During Welding:**

- i. The welding parameter in the machine should be set as per recommendations of manufacturer.
- ii. If welding is carried out by MMAW process, connect the electrode with positive terminal of welding equipment (DC+) when welding with DC.
- iii. Use 70 OCV (min) transformers while welding with AC.
- iv. Keep the welding current on lower side (as possible) of the range as recommended by the manufacturer of the consumables.
- v. Maintain as short an arc length as possible to minimise the loss of alloying elements during welding.
- vi. Put stringer beads. Weaving should not be more than two times of the diameter of electrode used.,
- vii. Use small diameter electrode according to thickness of base metal to minimise heat input& ensure minimal distortion.
- viii. Each run should be property de-slagged by using stainless steel brushes and chisels.
- ix. Preheating of job is not required.
- x. For cutting of stainless steels plasma cutting or machine cutting shall be used. Manual metal arc cutting may also be used in case when plasma arc cutting or machine facility is not available.

#### **5.5.5 Precautions After Welding:**

- i) The weld reinforcement of stainless steel welds must be grounded.
- ii) The stainless steels are susceptible to corrosion if the surface is rough. To avoid the corrosion, surface should be made smooth & polished. It is therefore, necessary to finish the stainless steel joint by grinding & subsequent polishing using fine grinder.
- iii) Post- weld cleaning should be undertaken on all weld areas (weld material and HAZ),arc strikes and points where cleats, lugs etc..have been welded.

### 35.5.6 Electrodes For Welding:

The welding electrodes to be used for repairs of IRSM:44 material are indicated below:

S. No	Material to be welded	Electrodes/filler wire to be used
1.	IRS M-44 to IRS M-44	<p>MMAW electrodes approved under class M1 as per IRS M-28-02 shall be used.</p> <p>MMAW electrodes of diameter 2.5 mm/4.0 mm shall be used depending upon the thickness of the plate.</p> <p>Re-dry the electrodes before use to about 150°C for atleast one hour or as recommended by manufacturers.</p> <p>MIG/MAG welding filler wires approved under class VI as per IRS M46-03 shall be used. The diameter of the wire shall preferably be 1.2 mm/0.8 mm.</p>
2.	IRS M-44 to IRS M-41	As per G-72 Rev-3 or latest.
3.	IRS M-41 to IRS M-41	

**Note:**

1. The edge preparation should be done as per IS: 9595 for both “V” butt as well as fillet joints.
2. Electrodes and filler wires should be procured from any RDSO approved sources and the parameters like current, voltage, etc. should be as per IS code and manufacturers recommendations.
3. For other combination of materials welding Refer RDSO specification No.G-72 Rev-3 or latest appendix-III.
4. **Welders` Qualification:** Welders deputed to carry out welding work on wagons and wagon components should be only those tested and certified as adequately skilled for welding work on stainless steel wagons and its components.

### 5.5.7 During welding of dissimilar metals, the following general guidelines shall be helpful:

- i. Minimum heat input should be provided to joint, so that diffusion can be restricted and dilution is minimised. To achieve this low welding current, small diameter electrodes shall be preferred.
- ii. Proper filler materials compatible with both the steels, being joined are to be used.

- iii. Dilution must be reduced to as low as possible. Dilution depends on the welding process, process variables and penetration. Hence, proper welding process shall be used with proper setting of process variables (Current, Voltage, Travel speed, Polarity etc.).
- iv. When using gas metal arc welding (MIG/MAG) reduced current density is to be employed, so that only dip transfer of metal occurs.
- v. The problem of dilution and formation of inter-metallic phases can be minimised by buttering one or both joint faces with a layer of compatible material.

## **6. SURFACE PREPARATION & PAINTING**

- i. The surface preparation and painting for underframe of the wagon shall be as per standard specification No.G-72 read with latest amendments.

### **ii. Surface preparation of the wagon body**

Degreasing with petroleum hydrocarbon solvent to IS:1745-1978 (low aromatic grade 145/205) or any other degreaser (applicable for both SS,MS and corten steel).

### **iii. PAINTING OF WAGON BODY**

Wherever the wagon is repaired it must be dressed to smooth surface and proper protective coating i.e. paints to be applied as recommended.

#### **For stainless steel**

As specified in the relevant drgs/ specifications or General Standard Specification No. G-72 (Rev.3) read with latest amendments.

- iv. The painting of bogies, couplers and air brake equipment shall be done as given in Para 11.2.5 of General Standard Specification No. G-72 (Rev.3) read with latest amendments.

**References:**

- (i) General guidelines for fabrication of stainless steel (IRS M:44) wagons and requirements for ensuring quality during manufacturing issued by Wagon Directorate, RDSO in Oct. 2007.
- (ii) Guidelines and facilities required for fabrication/maintenance of stainless steel wagons Issued by CAMTECH vide No. Camtech .M/W/SS Wagon-1.0 in December-09.
- (iii) Maintenance Manual of LHB Coaches /Wagons a draft copy by CAMTECH/Gwalior.
- (iv) Welding procedure for joining various types of stainless steel parts with mild steel/corten steel parts used in carriage & Wagons based on procedure No. MC-97 Issued by M&C Directorate, RDSO, Luck now
- (v) Minutes of the seminar on welding technology-“Focus on Railway workshops”, held in Railway Board on 18.01.2011.
- (vi) General standard specification No. G-72, Issued by wagon Directorate, RDSO, Lucknow.

**Appendix-VII****Long Haul Train Operation****Introduction of Long Haul Train**

A composition of more than one standard train formation is defined as Long Haul train. The constituent trains may be empty or loaded. The running of long haul trains will help in reducing the congestion in busy sections thereby increasing the throughput. It has added advantage of increasing the speed of rolling stocks as a result of reduction in number of trains. These trains run with planned nomenclature on zonal Railways. Long haul trains run in nominated sections only. The name like Maruti, Python will be prefixed with train name and clearly marked in FOIS & control charts. Separate Colour code will be provided in FOIS and control charting to distinguish these trains from other trains. It shall be relayed to station masters of adjoining stations while asking line clear. These rakes only be formed at notified stations with TXR presence. In case, there is no TXR point, TXR should be arranged at that point. In case of precedence, crossing of passenger carrying trains and during exceptional circumstances, the train may be split at any station with adequate precautions.

**Composition of long haul train:**

<b>Front Load</b>	<b>Rear load</b>
Empty Train	Empty Train
Loaded Train	Loaded Train
Loaded Train	Empty Train

**General requirements for long haul train:**

1. The long haul trains can be BOXN/BCN/container or steel rakes with single/twin pipe air brake system.
2. The maximum speed of long haul train shall be restricted to lower of the maximum speed of constituent train.
3. Identified sections for long haul trains will be provided additional / special T/G boards for long haul trains.
4. Due to curve, length or visibility obstructions when it is not possible to exchange signals physically, the exchanging of signals shall be done by using Walkie-Talkie sets. If Walkie-Talkie communication fails, the long haul train shall be brought to stop at the next station & should not be continued.

## Appendix-VII Long Haul train operation

5. Loco pilot selected from “A/B” category, well conversant with the section and with adequate experience only should be nominated to work Long Haul train. Names of such LPs screened and nominated for Long Haul trains should be displayed in the crew booking lobbies.
6. On middle loco, crew will be provided. Loco pilot of middle loco will notch up throttle as per advice of loco pilot of leading loco. Prescribed whistle code shall be used for communication between LP & Guard.
7. In case of train parting, G&SR Rule (Train Parting) should be strictly followed.

### Technical requirement for Long Haul Train

#### A. Locomotive

1. Single/ MU loco as per haulage capacity of the loco to the haul the train shall be provided for long haul train in leading for smooth operation.
2. In case of loaded-loaded or loaded–empty combinations hauled by electric locomotives, atleast five compressors of the leading MU unit will be in “ON” condition. Locomotive in the middle of the LH Rake are not permitted to charge the brake pipe. Leading locomotive will work the train and trailing locomotives will be just a piped vehicle that can provide additional power when required.
3. It should be ensured that RB/DB of leading locomotives are in working condition.

Long haul loco operation without use of distributed power system in tabulated as under;

Locomotive	BP Creation	Powering	Braking	Emergency Braking
Leading Loco(S)	Yes	Yes	Yes	Yes
Middle Loco (S)	No	Yes/ No #	No	Yes

# = May be selected on the basis of Load hauled

#### B. Loco Crew:

1. The long haul trains shall be started from originating station by exchange of physical signals (flag or light and whistle by guard between guard and loco pilot.
2. Nominated Loco Pilot should only be selected from “A/B” category well conversant with the section and with3. Before restarting the train after brake application, the loco pilot shall ensure that BP pressure in engine and in the brake van has been restored. The Guard in the rearmost brake van shall confirm this to the loco pilot in the leading loco. A minimum 5 minutes release time shall be ensured by driver in section before restarting the train.
4. While observing the caution order, loco pilot should notch up and notch down judiciously and control the train by RB as far as possible minimizing the use of train brakes. Entry and Exit into RB and out of it should be gradual for first two notches allowing 10-20 seconds for first two notches each.



## Appendix-VII Long Haul train operation

5. At the time of starting of two loaded or one loaded & one empty rakes combination, Middle Loco Pilot (MLP), shall first take two notches and confirm the same to the Leading Loco Pilot (LLP) through Walkie-Talkie. Then LLP shall start notching up. The MLP shall then co-ordinate with LLP for further notching.
6. In case of loco of long haul train is changed on any account, the air brake system of the full load should be released to avoid brake binding.

**C. C&W (Carriage & Wagon)**

1. The two rakes clubbed in Long Haul trains shall have valid BPC s for individual rakes separately.
2. Two separates rakes with separate valid BPCs shall be clubbed and worked as one train. To ensure safe operations of such trains, carriage & wagon staff will issue a separate Air Pressure Continuity Certificate. Air pressure continuity test shall also be conducted before start
3. While starting the Long Haul train, minimum BP pressure in engine shall be 5 Kg/cm<sup>2</sup> and in the rear brake van 4.7 Kg/cm<sup>2</sup>.
4. 8-wheeler brake van, if available, shall be marshaled in between the two empty rakes. If both brake vans are 4-wheeler, both shall be attached in rear of the train.
5. Divisions shall follow instructions given in G&SR for detaching wagons on account of hot axle, flat tyre etc. in long haul trains.

**D. Communication:**

1. Pre tested VHF sets of adequate power with spare battery should be provided to Loco Pilots and Guards for reliable communication during run.
2. The entire crew shall ensure before start that their walkie-talkie sets are in working order and communication is smooth from front to the rear of Long Haul train.
3. Crew shall use walkie-talkie set to facilitate exchange of all right signals in case of inadequate visibility due to long length of Long Haul train.
4. The divisions shall ensure suitable walkie-talkie sets are provided to the entire crew of Long Haul train for better communication along the route.
5. The Long Haul train shall not be operated during all Communication failure or in Temporary Single Line working

**E. Operating (Traffic)**

1. The Long Haul trains shall be run on single line clear. The tail board / tail lamp as the case may be, shall be provided only in rear of the rear-most vehicle. No tail board/ tail lamp as the case be, shall be provided in rear of the middle brake van.
2. Air pressure shall be created by leading locos only. The middle / banker locos will not be charging the BP. Brake shall be applied only by the LP of leading loco and LP of middle/ banker loco shall bring his loco on idle on application of brakes by the leading LP.
3. The maximum speed of LH train shall be 60 Kmph for loaded rake or booked speed of stock/ loco for empty long haul; subject to other speed restrictions in force from time to time.
4. The loco pilot of middle/ banker loco shall push the train as per requirement in co-ordination with LP of leading loco.

*Appendix-VII Long Haul train operation*

5. The Guard of the rear most brake van shall be in-charge of long haul train, however middle brake van shall also be manned.
6. The guard of the long haul train shall ensure safety of rear portion of train to avoid rolling down (application of hand brakes) when stabled after shunting.
7. Guard of the train will communicate over walkie-talkie about clearance of speed restriction zones and cross-over to the Loco Pilot of the train.
8. As far as possible, section controllers will ensure that through line clear is given to long haul trains to avoid detention to the following trains.
9. All rules of G&SR for working of trains shall be applicable for running of long haul trains also.
10. Marshalling of rakes shall be such that, Loaded rake is always the leading rake followed by empty rake.

**F. Other Important Instructions:**

1. Repercussions caused due to any failure related with long haul trains being run on trail may be booked on "OTHERS" account.
2. First ten trial trips of long haul trains on a particular section should be monitored by deputing LI and TI on the locomotive and rear brake van. Running of long haul trains will be reviewed on the basis of joint reports, highlighting shortcomings observed during the run submitted by divisions.
3. For monsoon working, sanders of all locos should be in working order and monsoon time table for deployment of locos should be followed.
4. Running of long haul trains should be covered in ZRTI syllabus as soon as possible.
5. All crew working long haul trains and PCOR/ TLC/ CCOR should be given a pamphlet containing instructions on long haul trains.
6. If required, divisions may issue local instructions based Rlt. Bd. JPO to take care of specific topography, operating issues etc.
7. Sr. DSOs of the divisions and Safety Counselors should carry out checks on such trains to ensure that violation of safety rules is not taking place.
8. In case of train parting, longer front portion may be cleared to next suitable capacity loop line station and rear portion may be taken at rear or front stations according to situation and availability of locomotive.

**Long Term Strategy for long term movement :**

Following methodology is suggested by Railway Board for long term movement plan of long haul train on IR network :

**Operation of loaded long haul trains heavier than 9000T :**

For operation of loaded long haul trains heavier than 9000T and at a speed above 60 Kmph. RDSO shall conduct field trials with different class of locos to determine EBD before permitting such operation.

**Introduction of twin pipe on goods train :**

This can be started from BCNHL,BOXNHL & BLC type wagons to begin with and later adopted on all BOXN type and BCN type wagons. Single pipe system has problem of brake pressure fading and propagation delays in application and release of brakes. In case of

emergency braking, release is seen to take longer than 950 sec. in initial trail. This would become a limitation in unrestricted adoption on long-haul. Hence BCN, BOXN & Flat wagons and loco should be converted to twin pipe within next 5 years.

**LOCOTROL:**

Manual system of ensuring co-ordination between front and middle locomotives in a long haul train has limitations and possibilities of errors. Also, the two Traction units are not able to work fully in a synchronized mode, i.e, powering, releasing and applying brakes together without use of a second crew in a middle loco set. Use of distributed power system involving use of LOCOTROL type systems should be adopted universally on all locomotives. However since existing LOCOTROL is not a portable device, railways may have to draw a strategy to confine long haul locomotive in a closed circuit or alternatively portability of LOCOTROL may have to be examined. In case portable LOCOTROL is not practicable, LOCOTROL may be made a part of locomotives.

**Infrastructure :**

As long term strategy, Railways should expeditiously construct longer loop at a distance about 50 Kms to avoid any detention of coaching trains enroute and to maintain order of precedence. Longer loops may be constructed on priority on a section where doubling/tripling/quadrupling of section on way. These longer loops can be constructed at convenient stations where such constructions do not require construction of bridges/culvert etc. These longer loops subsequently can be converted as a part of running line etc.

**Training of Staff :**

To develop a confidence among the staff, it is necessary that they should be properly trained. On the basis of experience gained, a separate module on running of long haul trains should be developed by ZTS and to be taught to Loco pilots, Guards and station Staff as a part of their refresher and initial training.

\*\*\*\*

**Appendix-VIII****Check Lists for Inspection of Wagon Stock****CONTENTS**

<b>SN</b>	<b>Particulars</b>	<b>Page No.</b>
01	Check list for Inspection of Freight Depots	04
02	Check list for Intensive Examination of Air brake trains	06
03	Check list for Super Checking of Examined loads in Yards	08
04	Check list for Freight Sick Line	10
05	Check list for Safety Audit of Wagon ROH Depots (Part-I)- Vital information	12
06	Check list for Safety Audit of wagon ROH depots	14
07	Check list for Work Areas where attention to be given (Wagon)	15
08	Check list for Freight Sick Line Maintenance	20
09	Check list for Safety Audit of Wagon ROH Depots – Vital information	22
10	Check list for Safety Audit of Wagon Depots	23
11	Check list for Safety Audit of Wagon ROH Depots Air brake system Reference G-97	24
12	Check list for Safety Audit of Wagon ROH Depots Casnub Bogie- Reference G-95	25
13	Check list for Inspection of Wagon Tippler	26
14	Check list for Train Parting in Freight stock.	28
15	Check List for Investigation of CBC Uncoupling	31
16	Check List for Reporting Hot Axle on Wagon Stock	34
17	Check List for Inspection of In-Motion Weigh-bridges	35
18	Check list for analysis of BP Air hose uncoupling.	37
19	Check list for reporting Flat tyre	38
20	Check List for Wheel Impact Load Detector ( WILD)	40
21	Checklist for investigation of Brake binding	42

## MECHANICAL DEPARTMENT

### MINIMUM QUOTA OF INSPECTION PER MONTH

#### 1. DIESEL LOCO SHEDS.

Activity per month	JA	SS	JS	Supervisors DF / EF
Super check of Diesel locomotives	4	4	6	8

#### 2. OPERATIONAL ASPECTS

SN	Type of inspection	JA	SS	JS	Supervisors	
					SSE/SE	SLI/LI
1	Foot plate	3	5	8	-	12
2	Crew booking (Day/Night)	1/1	2/1	2/1	4/4	2/2
3	Running room	1	1	1	1	1
4	Ambush check	1	1	1	-	2
5	Safety seminar	Qtly	Qtly	Qtly	1	-
6	DSL installation [RCD]	1	1	1	2	1
7	ART	Qtly	Qtly	Qtly	1	-
8	Monitoring of Drivers and Asstts.	Each driver & Asstt. is assigned to a SLI/LI. They must be covered once in three months				
9	140 Te. Crane	Qtly	Mly	Mly	Bi Mly	-
10	ARME/SPART	Qtly	Mly	Mly	Bi Mly	-

#### 3. COACHING MAINTENANCE

SN	Type of inspection	JA	SS	JS	Supervisors
	Rake inspection/Month (under gear & Passenger amenities)				
1	Washing Line	2	3	4	10
2	Platform	2	3	4	10
3	Running	1	1	2	02
4	Sick line inspection	1	2	2	02

#### 4. COACHING DEPOT INSPECTION

SN	Type of Inspection	JA	SS	JS	Supervisors
1	Major	1	1	1	Once every month in the nominated beat
2	Medium	1 B.Mly	1 B.Mly	1	- do -
3	Minor	1 B.Mly	1	1	- do -
4	Bk.Power checks	1	2	4	04
5	Qly. Joint inspection of infrastructural facility of Coaching maintenance Depot, Examination Yard and Sick lines with Engg. & Elect. Officer.	1	1	1	1 (Mly)
6	Night inspection	1	2	2	2

#### 5. FREIGHT OPERATION

SN	Type of inspection	JA	SS	JS	Supervisors
1	<b>Sick line</b>	1	2	2	2
2	<b>Yard</b>	2	2	3	3
3	<b>ROH Depot</b>	1	1	1	1
4	<b>Night inspection</b>	1	1	1	2
5	<b>Super check of goods rake</b>	1	2	4	4
6	<b>SIG / Joint Inspection</b>	1	1	1	-
7	<b>Office inspection</b>	1	1	1	1
8	<b>Brake Power checks (Goods trains)</b>	2	2	4	4
9	<b>Qualities of GDR Check</b>	1	1	2	4

## INSPECTION OF FREIGHT DEPOT

**[Railway Board's letter No.2009/M(Safety)/7/2/Check.List.Inspections dated 09.09.2009]**

Following areas to be inspected by the Supervisors/Officers to ensure general upkeep and smooth functioning of Freight Depots.

SN	Description	Status
01	<p style="text-align: center;"><b>ROH RELATED ITEMS:</b></p> <ol style="list-style-type: none"> <li>1. System for identification of repairs and ensuring the completeness thereof.</li> <li>2. Availability of unit exchange spares mainly trolleys, springs and wheels.</li> <li>3. Availability of must-change items, system, monitoring and audit checks.</li> <li>4. Attention to welding practices, particularly of earthing.</li> <li>5. Availability &amp; use of gauges.</li> <li>6. Quality of repairs and attention to schedule items.</li> </ol>	
02	<p style="text-align: center;"><b>SICK LINE RELATED ITEMS:</b></p> <ol style="list-style-type: none"> <li>7. Adequacy of lifting facilities.</li> <li>8. Attention to welding practices particularly earthing.</li> <li>9. Cylinder overhauling.</li> <li>10. Air pressure testing of stock after repairs in sick line.</li> <li>11. NTXR rejection and analysis thereof.</li> <li>12. Road access and availability of material handling equipment.</li> </ol>	

## Appendix-VIII Check lists for Inspection of wagon stock

SN	Description	Status
03	<p><b>MANAGEMENT INFORMATION SYSTEM:</b></p> <p>13. Analysis of failures.</p> <p>14. Analysis of average examination time.</p> <p>15. Compliance of imprest items and availability of critical materials like brake blocks, brake block keys, brake gear pins, etc.</p> <p>16. Trend of expenditure - unit cost and inventory.</p> <p>17. Identification of training needs and training.</p> <p>18. 100% implementation of safety related modifications.</p> <p>19. Use of bulb cotters in place of split cotters.</p> <p>20. Ultrasonic testing of axles. Please make surprise check of an axle already cleared.</p> <p>21. Provision of spare templates for worn out wheel profile for tyre-turning of wheels.</p> <p>22. Analysis of freight trains.</p> <ul style="list-style-type: none"> <li>- Examined in loaded/empty condition.</li> <li>- Running with invalid BPCs.</li> <li>- Coming for intensive exam. with open doors.</li> </ul>	
04	<p><b>BRAKE GEAR AND WHEELS:</b></p> <p>1. Complete inspection of running gear fittings.</p> <p>2. Correct fitment of brake gear pins, split pins &amp; bulb cotters.</p> <p>3. Tapping and gauging of wheels.</p> <p>4. Check wheels free from defects as per IRCA rule book.</p> <p>5. Hand brakes to check for working.</p> <p>6. Check empty load box in correct position.</p>	



## Appendix-VIII Check lists for Inspection of wagon stock

05	<p><b>SAFETY FITTINGS:</b></p> <ol style="list-style-type: none"> <li>1. Checking of Safety brackets, safety loops &amp; safety fittings</li> <li>2. Checking correct and sound fitment of AR holding straps</li> </ol>	
06	<p><b>BOGIE FRAMES AND SPRING GEARS:</b></p> <ol style="list-style-type: none"> <li>1. Check for cracks on horn gaps.</li> <li>2. Replace cracked/Broken springs</li> <li>3. Repair cracks/welding failures of SSB/DSB</li> <li>4. Bridle bar fitment</li> </ol>	
07	<p><b>BRAKE POWER:</b></p> <ol style="list-style-type: none"> <li>1. Check for adequate pressure level</li> <li>2. Ensure proper adjustment for piston stroke</li> <li>3. Leakage rate should be within prescribed limit.</li> <li>4. Check for proper mating of brake block on wheel treads.</li> <li>5. Check, corrections of 'A' Dimension clearance of SAB regulator and ensure proper working.</li> <li>6. Ensure brake block thickness above 20 mm</li> <li>7. Ensure minimum of brake power and six out of 8 wagons in front and rear to be operative</li> <li>8. Fitment of quick coupling/Adopter'B' in brake van to be ensured.</li> </ol>	
08	<p><b>MISCELLANEOUS:</b></p> <ol style="list-style-type: none"> <li>1. Check buffer heights</li> <li>2. Check proper security of doors (covered wagons)</li> <li>3. Check proper packing/lashing &amp; securing of consignment</li> <li>4. Inspection of draw and buffing gears</li> <li>5. Ensure proper locking of CBC</li> </ol>	

Date :  
Station :

Name of the Officer :  
Designation :

## Intensive Examination of Air Brake Trains.

[Railway Board's letter No.2009/M(Safety)/7/2/Check.List.Inspections dated 09.09.2009]

Ensure 100% rolling-in-examination for loose brake gears / skidded wheels / hot box before intensive examination.

SN	Description	Status												
01	<p><b>I. BRAKE GEAR AND WHEELS:</b></p> <ol style="list-style-type: none"> <li>1. Complete inspection of running gear fittings.</li> <li>2. Brake rigging pins &amp; safety brackets in proper working condition.</li> <li>3. Tapping and gauging of wheels to be ensured.</li> <li>4. Wheels to be checked and should be free from defects as per IRCA rule book.</li> <li>5. Hand brakes of wagons to be fully released.</li> <li>6. Operating handle of empty load box in correct position.</li> </ol>													
02	<p><b>II. BRAKE POWER:</b></p> <ol style="list-style-type: none"> <li>1. Check brake pipe pressure and ensure :- <table border="1" style="margin-left: 20px;"> <thead> <tr> <th></th> <th style="text-align: center;">No. of wagons</th> <th style="text-align: center;">Engine</th> <th style="text-align: center;">Brake Van</th> </tr> </thead> <tbody> <tr> <td style="text-align: center;">a</td> <td>Upto 56 wagons</td> <td style="text-align: center;">5.0 Kg / cm<sup>2</sup></td> <td style="text-align: center;">4.8 Kg / Cm<sup>2</sup></td> </tr> <tr> <td style="text-align: center;">b</td> <td>Above 56 wagons</td> <td style="text-align: center;">5.0 Kg / cm<sup>2</sup></td> <td style="text-align: center;">4.7 Kg / Cm<sup>2</sup></td> </tr> </tbody> </table> </li> <li>2. Ensure leakage rate within prescribed limit.</li> <li>3. Proper adjustment of piston stroke. Ensure within specified limit after brake application.</li> <li>4. Proper mating of brake block on wheel treads.</li> <li>5. Proper working and correct 'A' dimension clearance of SAB Regulators.</li> <li>6. Ensure minimum percentage of operative cylinders as per specified limits.</li> <li>7. Ensure continuity of brake pipe connection and conduct continuity test.</li> <li>8. Ensure working of guard's emergency brake valve and proper fitment and working of quick coupling.</li> <li>9. Ensure brake cylinder piston fully inside and brake blocks having clearance from wheels, after release of brakes.</li> </ol>		No. of wagons	Engine	Brake Van	a	Upto 56 wagons	5.0 Kg / cm <sup>2</sup>	4.8 Kg / Cm <sup>2</sup>	b	Above 56 wagons	5.0 Kg / cm <sup>2</sup>	4.7 Kg / Cm <sup>2</sup>	
	No. of wagons	Engine	Brake Van											
a	Upto 56 wagons	5.0 Kg / cm <sup>2</sup>	4.8 Kg / Cm <sup>2</sup>											
b	Above 56 wagons	5.0 Kg / cm <sup>2</sup>	4.7 Kg / Cm <sup>2</sup>											

## Appendix-VIII Check lists for Inspection of wagon stock

03	<b>III. MISCELLANEOUS:</b> <ol style="list-style-type: none"> <li>1. Ensure all angle cocks ( except at rear end of train) are kept open.</li> <li>2. Ensure isolating cock of DVs to be in open position.</li> <li>3. Ensure BP &amp; FP coupling at rear end of train is placed on support.</li> <li>4. Ensure CBCs are properly locked and operating handles properly secured.</li> <li>5. Ensure proper closing of doors.</li> </ol>	
04	<b>IV. ADDITIONAL ITEMS FOR BOBR / BOBR'N' WAGONS:</b> <ol style="list-style-type: none"> <li>1. Load sensing Device (LSD) to be checked for proper working.</li> <li>2. Ensure clearance between operating valve and spring buffer (LSD) within specified limits.</li> <li>3. Bolts and nuts of LSD to be properly tack welded.</li> </ol>	

Date :

Name of the Officer :

Station :

Designation :

## **SUPER CHECKING OF EXAMINED LOADS IN YARDS**

**[Railway Board's letter No.2009/M(Safety)/7/2/Check.List.Inspections dated 09.09.2009]**

Following items to be inspected by the Supervisors/Officers to ensure super checking of examined load in yards.

SN	Description	Status
01	<p><b>I. BRAKE GEAR:</b></p> <ol style="list-style-type: none"> <li>1. Correct size of fitment of Bk. gear pins, split pins &amp; bulb cotters.</li> <li>2. Correct sitting of brake blocks, brake shoe key &amp; split pin.</li> <li>3. Hand brake working.</li> <li>4. Empty load box correct handle position &amp; connection.</li> </ol>	
02	<p><b>II. SAFETY FITTINGS:</b></p> <ol style="list-style-type: none"> <li>5. Availability of sound safety brackets / loops.</li> <li>6. Correct and sound fitment of AR / VR holding strap.</li> </ol>	
03	<p><b>III. BOGIE FRAMES AND SPRING GEARS:</b></p> <ol style="list-style-type: none"> <li>7. Cracks on horn gaps.</li> <li>8. Bridle bar fitment.</li> <li>9. Spring breakages / cracks.</li> <li>10. Welding failures in SSB / DSB.</li> <li>11. Overloading of wagon.</li> </ol>	

SN	Description	Status
04	<p><b>IV. BRAKE POWER:</b></p> <p>12. Check of pressure level.</p> <p>13. Proper adjustment of piston stroke.</p> <p>14. Leakage rate within prescribed limit.</p> <p>15. Proper mating of brake block on wheel treads.</p> <p>16. Proper working and correct 'A' dimension clearance of SAB regulators.</p> <p>17. Brake blocks thickness to be above 20 mm.</p> <p>18. Six out of eight wagons to be operative in front and rear of load.</p> <p>19. Fitment of quick coupling / Adopter 'B' in the brake van.</p> <p>20. Ensure a minimum of 85% brake power for end-to-end running and 100% brake power for close-circuit running of Air Brake rakes.</p>	
	<p><b>V. GUARD AND DRIVER CHECK (EXAMINATION)</b></p> <p>21. Knowledge of Guard and Drivers for items to be checked.</p> <p>22. Quality of check being done by Guard/Driver.</p> <p>23. Check for correct method of continuity test being done by guard and driver.</p> <p>24. Endorsement of GDR check on BPC by Guard/Driver.</p>	

Date :

Name of the Officer :

Station :

Designation :

**CHECK LIST FOR FREIGHT EXAMINATION POINT****Railway** :**Type of attention** :**Division** :**Avg. no. of wagons attended** :**Type of stock** :

SN	Item	Availability		Remarks
		Yes	No	
1	7.5 m centre to center distance between two lines			
2	Concrete path way			
3	Paved road for truck movement			
4	Supervisors Room			
5	Staff room			
6	Rolling in/out huts			
7	Field Store + Tool room			
8	Compressor Room			
9	Exhauster room			
10	Battery Charging room			
11	Tower light			
12	Street light along examination lines at two levels			
13	Portable rechargeable light			
14	Hand Lamps			
15	Welding line			
16	Arc Welding set (Mounted on trolley)			
17	Portable DG Set			
18	DG set 250 KVA (for compressor, light & welding)			
19	Electric Compressor (500 CFM)			
20	Diesel Compressor (500 CFM)			
21	Exhauster			
22	Gas cutting set			
23	Hyd. Cold cutting set/ Hand shears			
24	Protective clothing with Helmet & Gloves			
25	Welding Apron & Welding glass.			
26	Pneumatic pipe line (32 mm dia.)			
27	Rake test rig			
28	Hydraulic Jacks			
29	Wheel Barrow			
30	Pick up van			
31	Truck			

## Appendix-VIII Check lists for Inspection of wagon stock

SN	Items	Availability		Remarks
		Yes	No	
32	Lister truck			
33	Road Mobile Crane			
34	Hand Trolley			
35	Portable drill machine 12mm			
36	Drill Machine			
37	Bending Machine			
38	Fitter tool box			
39	Pressure gauge test stand			
40	Folding type portable wheel diameter gauge			
41	Rail profile gauge cum recorder in box			
42	Wheel distance measuring gauge			
43	Buffer height gauge			
44	Tyre defect gauge			
45	Electronic device/ infrared thermometer for detecting worm box			
46	Electric operated hand tools i.e. grinder			
47	Pocket Jack (Hydraulic) 6 Ton capacity			
48	Hand Tools			
49	Storage rack with pigeon holes			
50	Rack with Locker			
51	Plain paper fax with P&T line			
52	Walkie Talkie set/mobile phone			
53	Railway Telephone			
54	BSNL Telephone			
55	Computer with printer, Scanner, UPS with preloaded softer & modem			
56	C&W Office furniture			
57	Railnet/Internet connection			
58	Plain paper copier			
59	First Aid Equipment			

**Other observations:****Signature of Inspecting Officer****Name:****Designation:**

**Check Sheet for Safety Audit of Wagon ROH Depots****(Part-1) – Vital information**

<b>Sr</b>	<b>Requirement</b>	<b>Observations</b>
1	No of Artisans on Roll	
2	No of Artisans overdue Refresher	
3	No of Supervisors on Roll	
4	No of Supervisors overdue Refresher	
5	No of Welders on Roll	
6	No of Welders overdue training at CRWS/BPL	
7	No of Wheels involved in ROH of BOXN/BCN in a month	
8	No. of wheels re-profiled during ROH	
9	% of BOXN/BCN Wheels re-profiled during ROH	
10	No. of Wheels UST done during ROH	
11	% of Wheels subjected to UST during ROH	
12	Periodicity of calibration of tools	
13	Records of Calibration of tools	
14	Periodicity of calibration of gauges	
15	Records of Calibration of gauges	
16	No of Safety items pertaining to the Depot	
17	No of Safety items out of stock (%)	
18	No of Safety items demanded	
19	No of Safety items supplied NIL	
20	No of Safety items supplied more than 50%	
21	No of Vital items pertaining to the Depot	
22	No of Vital items out of stock (%)	
23	No of Vital items demanded	
24	No of Vital items supplied NIL	



## Appendix-VIII Check lists for Inspection of wagon stock

25	No of Vital items supplied more than 50%	
26	Quality of riveting	
27	Quality of Welding	
28	Check that correctly procedure being followed for Ultrasonic Testing of Wheels	
29	Availability of Safety Brackets for a. Truss bar b. Push Rod c. Pull Rod	
30	Documentation of ROH Repairs: i. Schedule Forms ii. Check Sheets iii. Selected items recorded in Work Diary/ Register iv. Computerized Data	

**Signature** \_\_\_\_\_

**Name** \_\_\_\_\_

**Designation** \_\_\_\_\_

**Inspecting Official**

## Check Sheet for Safety Audit of Wagon ROH Depots

Sr.	Requirement	Ref. No.	Observation
1.	Provision of Boiler for Steam Cleaning		
2.	Steam Cleaning of Tank Barrels		
3.	Steam Cleaning of Bitumen and Molasses Tank Wagons		
4.	Cleaning of Tank for corrosive repairs		
5	Hydraulic Testing of Barrel		
6	Testing procedure for Barrel is ensured		
7	Testing of Sulfuric Acid Tanks and Caustic Soda Tanks at testing pressure of 4.22 Kg/cm <sup>2</sup>		
8	Pneumatic test at a pressure of 2.1 Kg/cm <sup>2</sup> for Hydrochloric Acid Tank Wagons provided with Rubber lining (no Hydraulic Test should be done)		
9	Testing of Tank Wagons used for Petrol and middle distillates of Petroleum and Vegetable oil.		
10	Overhauling and testing facilities for Master Valve.		
11	Overhauling and testing facilities for Bottom Discharge Valve.		
12	Testing of Safety Valve		
13	Testing of Blank Flange		

**Signature of** \_\_\_\_\_

**Name** \_\_\_\_\_

**Designation** \_\_\_\_\_

**Inspecting Official**

## WORK AREAS WHERE ATTENTION TO BE GIVEN IN ROH

S N	Nature of Repairs	Observation	
<b>1.</b>	<b>BODY REPAIR WORK (Common for all)</b>		
	<b>UNDER FRAME – Sole Bar</b>		
	Scrap the portion of the sole bar at door ways, clean and apply primer paint followed by Top coat		
	<b>SIDE WALL – Skirting</b>		
	1. Check and patch if corroded then apply primer and top coat on the patch		
	2. Side Doors – Check damage and repair clean & lubricate hinges		
	3. Side Pillars – Check cracks at the base & repair		
	4. Patching of body, roof, door or floor plates straightening bulged ends repairs to angle irons. Stanchions and crib angles etc.		
	5. Making wagons water-tight (Covered wagons)		
	6. Fitting/replacement of door fastening road, door cotter pin eye, both hook and eye locking pin on empty wagons and closing of doors.		
7. Fitting/replacement of door fastening rod guide, door hasp which requires riveting on empty wagons. Repairs by welding to door fittings.			
8. Hand rail/foot board deficient/ or damaged, insecurely fastened at door way of guard's brake van.			
<b>2.</b>	<b>UNDER GEAR REPAIR WORK (Common for all)</b>		
	1. Brake Linkage – Check free movement		
	2. Hand Brake – Check proper working		
<b>3.</b>	<b>BOGIE REPAIR WORK</b>		
	<b>CASNUB BOGIE</b>		
	<b>BOLSTER</b>		
	<b>1. Pocket slope liner</b>	Change liner if thickness less than 5 mm	
	<b>2. Rotation stop lugs</b>	Provide liners (thickness to suit) if dimensions less than 514 mm	
	<b>3. Inner Column Gib</b>	Provide liners (thickness to suit) if dimension less than 142 mm	
	<b>4. Land surface</b>	Provide liners (thickness to suit) if dimension less than 442 mm	
	<b>5. Outer Column Gib</b>	Renew by welding if dimension more than 241 mm	
	<b>SIDE FRAME</b>		
	<b>1. Column Friction Liner</b>	Change liner if dimension more than 455 mm	
	<b>2. Column sides</b>	Provide liners (thickness to suit) if dimension less than 209 mm	
	<b>3. Anti rotation lugs</b>	Provide liners (thickness to suit) if dimension more than 526 mm	
	<b>4. Key seat to pad 22 W</b>	Provide liners (thickness to suit) if dimension more than 276 mm	

## Appendix-VIII Check lists for Inspection of wagon stock

S N	Nature of Repairs		Observation
	<b>5. Crown Roof 22 WM</b>	Provide liners (thickness to suit) if dimension more than 321 mm	
	<b>6. Crown Roof 22 NL</b>	Provide liners (thickness to suit) if dimension more than 326 mm	
	<b>7. Pedestal Crown Sides</b>	Renew by welding if dimension less than 147 mm	
	<b>8. Pedestal Jaw 22 W</b>	Provide liners (thickness to suit) if dimension more than 275 mm	
	<b>9. Pedestal Jaw 22 WM</b>	Provide liners (thickness to suit) if dimension more than 283 mm	
	<b>10. Pedestal Jaw 22 NL (Short)</b>	Provide liners (thickness to suit) if dimension more than 195 mm	
	<b>11. Pedestal Jaw 22 NL (Long)</b>	Provide liners (thickness to suit) if dimension more than 241 mm	
	<b>12. Pedestal Sides 22 W</b>	Provide liners (thickness to suit) if dimension less than 102 mm	
	<b>13. Pedestal Sides 22 WM</b>	Provide liners (thickness to suit) if dimension less than 102 mm	
	<b>14. Pedestal Sides 22 NL</b>	Provide liners (thickness to suit) if dimension less than 78 mm	
<b>WEDGE</b>			
	<b>1. Slope Surface</b>	Renew by welding if dimension less than 7 mm	
	<b>2. Vertical Surface</b>	If vertical surface from centre line of spigot less than 56 mm provide liner of 6 mm thickness	
<b>CENTRE PIVOT (BOTTOM)</b>			
	<b>1. Vertical Side 22 W</b>	Renew by welding if wear more than 4 mm	
	<b>2. Vertical Side 22 WM</b>	Renew by welding if wear more than 3 mm	
	<b>3. Vertical Side 22 NL</b>	Renew by welding if wear more than 3 mm	
	<b>4. Seat Side 22 W</b>	Renew by welding if wear more than 3 mm	
	<b>5. Seat Side 22 WM</b>	Renew by welding if wear more than 3 mm	
	<b>6. Seat Side 22 NL</b>	Renew by welding if wear more than 3 mm	
<b>COIL SPRING</b>			
	<b>1. Outer</b>	Group and use in sets. Replace if free height at or less than 245 mm	
	<b>2. Inner</b>	Group and use in sets. Replace if free height at or less than 247 mm	
	<b>3. Snubber</b>	Group and use in sets. Replace if free height at or less than 279 mm	
<b>ADEPTER</b>			
	<b>1. Crown Surface</b>	Replace if worn 3.5 mm or more	
	<b>2. Side lug</b>	Replace if wear more than 3 mm on either side	
	<b>3. Thrust shoulder</b>	Replace if depth exceeds 0.7 mm	
	<b>4. Machined relief</b>	Replace if depth less than 0.8 mm	

## Appendix-VIII Check lists for Inspection of wagon stock

	<b>BOGIE BRAKE GEAR</b>		
	Pins & Bushes	Change if clearance more than 1.5 mm	
<b>4.</b>	<b>AIR BRAKE SYSTEM</b>		
	Distributor Valve	Overhauling	
	Distributor Valve	Test on SWTR	
	DV Isolating Cock	Examine operation	
	DV Release Valve	Examine operation	
	DV Filter	Clean	
	<b>BRAKE CYLINDER</b>		
	Filter of Escorts & RPIL make	Clean	
	Brake Cylinder of Greysham & WSF make	Lubricate	
	<b>CUT OFF ANGLE COCK</b>		
	Angle cock	Examine and lubricate	
	Rubber Seals	Change	
	<b>DIRT COLLECTOR</b>		
	Dirt Collector	Clean	
	Sealing Ring	Change	
	<b>RESERVOIR</b>		
	AR & CR	Drain	
	Sealing Ring	Change	
	<b>METAL PIPES &amp; JOINTS</b>		
	Pipe Joints	Examine leakage & repair	
	Seal (20 mm & 32 mm) pipe	Change	
	Guard's Emergency Brake Van	Examine operation	
	Isolation cock of BVZC Brake Van	Examine operation	
	Quick Coupling	Examine operation	
	Load Sensing Device	Examine operation	
<b>5.</b>	<b>SLACK ADJUSTER (COMMON FOR ALL)</b>		
	Slack Adjuster	Testing Functioning, repair if required	
	"A" dimension	Adjust	
	"e" dimension	Adjust	
	M20 Anchor Pin nut	Ensure securing by welding to pin	
	Air Brake System	Test on SWTR as per procedure	
	Brake Block	Ensure Std. Key, Split pin & all new brake blocks	
		NB: For detailed main procedure refer RDSO manual G-97	
<b>6.</b>	<b>CENTRE BUFFER COUPLER (COMMON FOR ALL)</b>		
	<b>CBC BODY</b>		
	Coupler Body	Examine & replace on condition basis	
	CBC Counter	Examine, replace if required	
	Shank Wear Plate	Replace on condition	
	<b>KNUCKLE</b>		

## Appendix-VIII Check lists for Inspection of wagon stock

	Nose	Replace if wear more than 9.5 mm with HTE Knuckle	
	Knuckle Pin	Replace on condition	
	Knuckle Stretch	Examine, replace if required	
	<b>STRIKER CASTING</b>		
	Wear Plate	Replace	
	Striker Casting	Replace on condition	
	<b>COUPLER MECHANISM</b>		
	Anti Creep Protection	Examine and repair	
	Lock lift assembly	Examine	
	Operation Mechanism	Examine	
	Lock	Examine	
	<b>DRAFT GEAR</b>		
	Slack	Measure & take correction	
	<b>GENERAL</b>		
	Yoke pin support	Replace on condition	
	Buffer Height	Examine & Correct if required	
	<ol style="list-style-type: none"> <li>1. For detailed maintenance Practice in Open line refer RDSO's Manual G-76</li> <li>2. For detailed maintenance Practice in open Workshop RDSO's Manual G-80</li> <li>3. Knuckle with nose more than 4.3 mm and less than 9.0 mm can be used in Yard.</li> </ol>		
<b>7.</b>	<b>WHEEL AXLE &amp; BEARING (COMMON FOR ALL)</b>		
	<b>AXLE</b>		
	1. Ultrasonic Testing	To be carried in every ROH & reject if fails	
	2. Deep Notches due to gearing	Reject if deep is more than 5 mm	
	3. Axle end holes	Clean and lubricate in case end cover is opened	
	<b>WHEEL</b>		
	1. Tread profile	Check with tyre defect gauge	
	2. Height of flange	If height is more than 31 mm do not use under ROH wagon	
	3. Smooth flange	If flange not completely smooth do not use under ROH wagon	
	4. Wheel profile	Turn to WWP if above clause are not met for use under ROH wagon.	
	<b>BEARING TAPERED CARTRIDGE</b>		
	1. Cup	Rotate the bearing for unusual sound check up for Crack/chipping	
	2. Seal	Check seal for external damage/dent	
	3. Backing Ring	Check backing ring for looseness & vent fitting on backing ring with vent hole (the vent fitting should be intact or the vent hole should be plugged)	
	4. Locking Plate	Use new locking plate when ever and cover is opened	

Appendix-VIII Check lists for Inspection of wagon stock

	<b>5. Axle end Cap screw</b>	<b>Clean and lubricate in case end cover is opened</b>	
	<b>6. Load Zone Change</b>	<b>Change load zone area of the cup while lowering bogie side frame.</b>	

**Signature of**  
**Inspecting Authority:** \_\_\_\_\_

**Name:** \_\_\_\_\_  
**Designation:** \_\_\_\_\_

**CHECK LIST FOR FREIGHT SICKLINE MAINTENANCE**

<b>SN</b>	<b>Facilities Recommended</b>	<b>Facilities Available</b>
1	Covered Shed 100 M x 50 Mx 25 M	
2	SAB Repair Room 4x20 M	
3	DV Test room 4x14 M	
4	Service Building 4 x 25 M	
5	Computer room 4x14M or 5x7 M	
6	Store Room + Sub Store 4x30M or 5x15 M	
7	Machine shop 4x30M	
8	Compressor room 4x12 M or 5x9M	
9	SE/JE Room 4x7 M or 5x5 M	
10	Required 4 lines under covered shed.	
11	Distance between two lines.	
12	Other observations of Sick Line	
13	EOT Crane 15 T/5T -2 Nos.	
14	EOT Crane 10 T/5T -2 Nos.	
15	Road Crane 10 T. Cap. - 1 No.	
16	Jib Crane 2.5 T. - 6 Nos.	
17	Electrical stationary Screw Air Comp. (500CFM)	
18	Portable Diesel Compressor - 1 No.	
19	Trestles - 12 sets.	
20	DG set 500 KVA - 1 No.	
21	Work Station for Bogie Repair - 10 Nos.	
22	Fixture for Riveting spring plank - 2 Nos.	
23	Welding machines - 10 Nos.	
24	Bogie Mainpulators - 3 Nos.	
25	Fork lifter 3 Ton. - 2 Nos.	
26	Truck 10 Ton capacity - 1 No.	
27	Tractor with Hydraulic lifting Machine & 3 Trolleys (Trailers)	
28	Fork lifter 2 Ton - 2 Nos.	
29	Platform truck 2 Ton - 2 Nos.	
30	Light Store Vehicle - 1 No.	
31	Hand Trolleys with Rubber Wheels -- 10 Nos.	



## Appendix-VIII Check lists for Inspection of wagon stock

SN	Facilities Recommended	Facilities Avail.
32	First Aid Equipment - 4 sets.	
33	VHF sets / Mobile phones. - 10 Nos.	
34	Storage racks - As per layout.	
35	Portable Hydraulic Riveter - 1 No.	
36	Stores Bin - 20 Nos.	
37	CBC & Draft Gear Replacement equipment - 01 No.	
38	SAB Test bench - 1 No.	
39	DV Test stand - 1 No.	
40	Single Car Test Rig - 2 Nos.	
41	Ultrasonic Flaw Detector - 2 Nos.	
42	Pneumatic/Electrical hand tools - As per reqmnt.	
43	Pneumatic Torque Wrench With sockets 1" to 2" - 4 sets	
44	Repair facilities of DV	
45	Repair facilities of SAB	
46	Test & Repair facilities of Vac. Cylinders.	
47	Test & Repair facilities of Air brake cylinders	
48	Test & Repair facilities of Release valves	
49	Repair facilities of Brake beams	
50	Boiler for steam cleaning of tank wagons.	
51	Any other new items introduced	

**Check Sheet No.1 for Safety Audit of Wagon ROH Depots –****Vital information**

<b>SN</b>	<b>Requirement</b>	<b>Observation</b>
1	No.of Technician on Roll	
2	No.of Technician overdue Refresher	
3	No.of Supervisors on Roll	
4	No.of Supervisors overdue Refresher	
5	No.of Welders on Roll	
6	No.of Welders overdue training	
7	TSO's circulars and instructions whether acknowledged by Supervisors	
8	Competency certificate issued to safety category artisans as per TSO's	
9	Training programme of skilled artisans for promotional and refresher course.	
10	No.of Wheels dealt in ROH of BOXN/BCN in a month	
11	No.of wheels reprofiled during ROH	
12	% of BOXN/BCN wheels reprofiled during ROH.	
13	No.of wheels UST done during ROH.	
14	% of Wheels subjected to UST during ROH.	
15	Techniques being followed for Ultrasonic Testing of wheels.	
16	Periodicity of calibration of tools.	
17	Records of calibration of tools.	
18	Periodicity of calibration of gauges	
19	Records of calibration of gauges.	
20	No.of Safety items pertaining to the depot.	
21	No.of safety items available and out of stock (%)	
22	No.of Vital items available and out of stock (%)	
23	No.of Vital items pertaining to depot.	
24	Availability of Safety Brackets for Truss bar, Push Rod, Pull Rod.	
25	Type of Documentation of ROH Repairs maintained: i. Schedule Forms ii. Check Sheet. iii. Selected items recorded in Work Diary/Register iv. Computerized Data	

**CHECK SHEET NO. 1A OF SAFETY AUDIT**

1	Adequacy of Tools and equipments.	
2	Whether air compressor, exhauster, welding plants. EOT are in working order. Whether any Machine due for schedule repair.	
3	v) General cleanliness of shed. vi) Housekeeping of depot.	
4	Whether placement and removal of sick wagons is timely done.	
5	Knowledge of Artisans.	
6	Condition of Service Building.	
7	Condition of floor, roof, valley gutters and drainage system.	
8	Condition of staff Toilets.	
9	Condition of insulation of power cables.	
10	Adequacy of power supply and illumination.	
11	Adequacy of water supply	
12	Adequacy of drinking water.	
13	Standby DG set arrangement.	
14	<b>Stores section</b> v) Stacking of spares, oil and grease vi) Stacking of scrap materials. vii) Disposal of scrap materials. viii) Record of receipts and issues	
15	Monitoring of safety and vital items.	
16	Accountal of despatch & receipt of wheels.	
17	Accountal of despatch & receipt of springs.	
18	Any other remarks	

Signature of \_\_\_\_\_  
Inspecting Official

Design.

**Check sheet for safety Audit of Wagon ROH depots****AIR BRAKE SYSTEM REFERENCE G- 97****Wagon No.**

SN	Requirement	Observation
1	Testing of individual wagon using single wagon testing Rig as per prescribed procedure & proforma	
2	All pipe joints and connections are tested with soap solution for defecting leakages.	
3	Cut off angle cock is replaced, if it is leaking or damaged, by required and tested Angle cock Smooth operation of angle cock.	
4	Drain plug of dirt collector & Aux. Reservoir are Opened, condensate is drained out and leather washer is replaced, if found defective, Condition of Drain plugs.	
5	Filter is removed cleaned in soap solution Tank, Blown dry with compressed air and refitted back	
6	Brake cylinder is tested for smooth movement of piston and piston is lubricated.	
7	Defective Brake cylinder is replaced by duly tested Brake cylinder.	
8	Visual examination for Gaskets of Hose Couplings and replaced, if found damaged.	
9	Provision of Hose coupling support and APD on Angle cocks at both end.	
10	Dismantling/assembling of DV assembly and pipe bracket is done as prescribed.	
11	Specified Tools and ROH Kits are available for DV repair.	
12	Overhauling is being done by Trained persons.	
13	DVs tested for all the parameters on a Test Bench as given in the format. Check the record.	
14	All the components of ROH Kit replaced irrespective of condition.	
15	Repaired and tested DVs being stored in a clean and dry place.	
16	All Inlet ports of DV and pipe bracket are covered with protective cap.	
17	Wagon is again tested on SWTR.	
18	Fitment of single piece load sensing Device on BOBRN/BCC Wagons circulated vide RDSO's Letter No.MW/APB/LSD/ dated 06.02.02 & their working.	
19	Single wagon testing proforma used.	
20	Piston stroke.	
21	SAB Regulator	
22	Empty / Load Box	
23	Brake Ratio	
24	BP pipe line all joints with soap solution.	
25	Air reservoir condition, Security of straps.	

Signature of \_\_\_\_\_  
Inspecting Official

Name:

Design.

**Check sheet for Safety Audit of Wagon ROH depots****CASNUB BOGIE - REFERENCE - G-95.**

<b>SN</b>	<b>Requirement</b>	<b>Status</b>
1	Free height determined and Grouping of Coil springs is done and mixing of new and oil springs avoided.	
2	Retro fitment of EM Pads with wide Jaw Adapter.	
3	Dis-assembly of Casnub Bogie as per procedure.	
4	Reassembling of Casnub Bogie as per procedure.	
5	Nominal clearance and tolerance are maintained as prescribed.	
6	Wear of Bolster, Side Frame and Wedge surfaces.	
7	Repairs being undertaken on Bolster and Side frame on manipulators for down hand welding.	
8	Check the use of class of electrode, Gauge of electrode, Welding current and Welding precautions during repair as prescribed and procedure for welding of liner.	
9	Usage of Gauge to measure wear on Bolster Column gibs and Seat and sides of Centre Pivot Bowl.	
10	Determination of wear on outside and inside of side frame columns, Friction Plate, Pedestal Jaw crown roof and sides with proper gauge.	
11	Use of proper size and material of liner on side frame columns, Friction Plate, Bolster pocket slope & CBC.	
12	Check determination of wear (by using proper gauges) on, Thrust Shoulder, Adapter Bore, Adapter Crown Lug and Adapter sides.	
13	Visually inspected for crack or breakage.	
14	Whether nominal dimensions of EM pad and CC pad are recorded and condition for cracks, breakages, band failure and crushing of rubber checked.	
15	Wear of Friction shoe wedge block on both surfaces is determined by using proper gauge and reclaimed by welding Manganese Steel Liner of 120x10x2 mm using H2 Electrodes.	
16	Condition of Brake Gear Pins is visually inspected.	
17	Brake Power is adjusted by relocation of Pins in End Pull Rod	
18	Brake shoe is replaced when worn-out to 48 mm.	
19	Reclamation of Brake Beam on account of worn-out Brake Heads is done through welding on a fixture following proper procedure.	
20	Axle End screws are tightened by Torque Wrench at the specified Torque of 34-37 Mkgs.	
21	Fitment of modified side bearer housing of 95 mm height as per Drg.No.SK-69594 Alt.30	
22	Spring Plank deformation and condition of rivets inspected.	
23	Availability of set of 24 gauges for checking wear limit of: Side Frames, Bolster, Wedge & Adapter.	

Signature of \_\_\_\_\_  
Inspecting Official

Name:

Design.

## CHECK LIST FOR INSPECTION OF WAGON TIPPLER

SN	Component/Unit	Sr.	Items to be checked	Tippler No.1	Tippler No.2
<b>A.</b>	<b>End frame platform side beam</b>	01	Side beam to be examined for damages or defects		
		02	Check the condition & thickness for side beam rubber pad. The thickness of the pad should not be less than 50 mm.		
		03	Check & record the gap between the side stanchion		
<b>B.</b>	<b>Drive Gear</b>	01	Check proper matching of rack and pinion teeth & teeth wear.		
		02	Check whether coupling gives jerk during rotation .The tipping operation should be smooth & without any jerks.		
<b>C.</b>	<b>Top hydraulic clamp</b>	01	Check the level of clamp pad whether sitting properly or not .		
		02	Check the condition & thickness of clamp pad (thickness should not be less than 50 mm)		
		03	Check the smoothness of clamp movement.		
		04	Check for provision of indicator on the tippler table for all types of wagon stock which are likely to be tipped on the tippler. This is to ensure that wagons are placed on the tippler table in such a manner that the top clamping pads position is near the side stanchions. Force exerted by the top clamps should not exceed 1.5 Tonnes per clamp pad.		
		05	Check & record the value. Check for provision of a wagon bogie spring relief mechanism in the top clamp locks for permitting release of bogie springs.		
<b>D.</b>	<b>Rail Table of Wagon Tippler</b>	01	Check the level and alignment of the rail. The level of track on tippler table and that of approach rails should be the same so that the wagons do not experience any jerk during in-haul and out-haul.		
<b>E.</b>	<b>Limit Switches</b>	01	Check proper function		

SN	Component/Unit	Sr.	Items to be checked	Tippler No.1	Tippler No.2
<b>F.</b>	<b>In-haul &amp; Out-haul Stop Linkage</b>	01	Check satisfactory working of stop movement.		
		02	Check the Gradient on the out-haul side.		
		03	Check for provision of “Retarders” on the out-haul side		
<b>G.</b>	<b>Side Arm Charger</b>	01	Check damage /Defects of steel work. Check proper matching of drive.		
		02	Check Pinion and rack & tooth wear		
		03	Check smooth movement and final position of arm hoist.		
		04	Check the proper tightening of fastener & condition of track.		
		05	Check for functioning of Limit switches and proximity switches.		
<b>H.</b>	<b>Wagon Retarder</b>	01	Check for proper function, speed of the rolling wagons, it should not exceed 5 Kmph.		
<b>I.</b>	<b>Damages to Wagons</b>	01	Damage during tipping & Post Tipping Damages. <ul style="list-style-type: none"> <li>• Dents/Nick on the side stanchion, the copping wagon body etc.</li> <li>• Displacement of bogie pivot or suspension springs</li> <li>• Damages to air brake pipes.</li> <li>• Axle box adapter shifting.</li> <li>• Coupler damages</li> <li>• Any other defect.</li> </ul>		

**Note:**

1. After Tipping, empty wagons should not be coupled by loose shunting with the rake of loaded wagons. This is not acceptable.
2. Side Arm Chargers to be provided on the tipplers.
3. stamping of Weight & Measurer Department should be available on tippler

Signature :

Name :

## **Check List for Joint Investigation Report of Train Parting**

### General particulars:

Date		Km No.	
Division		Section blocked	
Time		Signal aspect	
Section		Curvature	
Gradient		Weather condition	
C/Order		Kms of caution Order:	

### Train Particulars:

Train No.		Loco (s) No	
Load / Tonnes-		Homing Shed of loco	
Commodity		Loading station	
Last Exam. Station		BPC Date / %	
Rly / Divn. -		BPC No	
CC /Pm /End to end		Air/Vacuum brake	

### Driver's particulars / (Train Engine & Banker)

Driver's Name		HQ	
Qualification		Safety Category	
Date of Appointment			
Guard's Name		HQ	

### Affected & Adjacent Wagon's Particulars

Sr. No.	Wagon No.	Class	Rly	R / Date	POH	ROH	Position from Loco
1							
2							

Screw coupling / CBC (Alliance II / AAR-HT):

Bearing: 16T RB / 20T RB / 20.3 T CTRB:

**Whether empty / loaded —**



**Checklist for Affected Wagons****CBC & Knuckles – HT/NHT Stamping Particulars –**

- Knuckle broken –
- CBC -crack any location –
- Zone of breakage (A / B / C / D) –
- Structure of broken surface (uniform / coarse) –
- Any mark of Blow Hole -
- Origin of breakage (External / Internal / dent or hit mark) -
- Nature of breakage (Fresh or partially fresh) –
- Approximate % age of crack (Fresh/old/any hair crack existing previously) –
- Any foreign material inside casting (stone / hard material, etc.) --
- Any other casting defect (Core sand deposit / uneven hard surface) –
- Knuckle is reclaimed by welding (Yes / No)
- CBC lock broken, fresh / Old with % -
- Any manufacturing defects on CBC lock (crack / unusual metal projections, etc)

**Draft & Assembly**

- Type of draft gear – (RF 361 / SL – 76 / MK-50 / HR-40)
- Draft gear condition (dislocated / tilted / stiff)
- Front end follower (intact with rivet / worn out)-
- Yoke pin (badly embedded in the yoke pin support plate) -
- Yoke pin support plate (intact with sound rivet) -
- Any other defect noticed –

**Operational Aspects**

- Statement of train drivers obtained or not -
- Statement of Banker's drivers obtained –
- Conclusions from statement of the drivers -
- Statement of Guard obtained or not - Obtained.
- Is there any empty wagon between two loaded wagons?
- Fluctuation of OHE voltage (as per SCADA report) –
- Tripping of DJ- as per driver statement & speedometer floppy–
- Operation of dynamic braking as per driver statement –
- Effectiveness of brake system from locomotive to the load – as per Dr's statement -
- Any evidences of wheel slipping – as per Dr's statement -
- Any evidences of brake binding of the rake as per Dr & Gd statement –
- Signal aspect. (Raised up on approach/ given on approach) –
- AFI condition while notching up.

**Loco particulars:**

- Dynamic Brakes : Working/Not working :
- Air Flow Indicator: Working/Not working :
- Notches –
- BP Pressure ( Engine & Brake van ) –
- MR / PT set No. –
- Flasher light ( Wkg / Not working) –
- Speedometer ( Wkg / Not working) –
- Release time after dropping 1 kg/cm<sup>2</sup> of BP pressure –
- Jerk while starting–
- Conjunction braking ( Working / Not working) –

**Track Particulars: -**

(a) Level (b) Rising (c) Falling (d) Curve right / left (e) Straight (f) Banner flag on track (g) Uneven rail joints (h) Cross over turn out (i) Camel hump (j) Vertical curve

**Time particulars:-**

Time left from station ----- at-----hrs.

Time arrival next station -----at -----hrs.

Running time of section –

Total section blocked –

**Nature of Occurrence –**

(a) While notching up (b) While notching down (c) During normal run (d) Coasting (e) While starting after stopping (f) While controlling (g) While observing caution order at km no.----- (h) Signal on approach (i) Running at the time of starting (j) Brake binding -on wagon no \_\_\_\_\_ ,position from engine (k) Gap between two portions \_\_\_\_\_mtrs (i) While entering loop line.

**Speed of train at the time of incidence - \_\_\_\_\_ kmph**

**Date of investigation:**

**Investigation:**

**Findings/Conclusion:**

**Responsibility:**

**Signature -  
Name -  
Designation -**

**Signature -  
Name -  
Designation -**

**Signature –  
Name –  
Designation –**

## **Check List for Investigation of CBC Uncoupling**

### **General particulars:**

Date		Block Section & KM	
Division		Section blocked	
Time		Signal aspect	
Section		Curvature	
Gradient		Weather condition	
C/Order		Kms of caution Order:	

### **Train Particulars**

Train No.		Loco(s) No.	
Load / Tonnes-		CC+8+2/CC+6+2	
Commodity		Loading station	
Last Exam. Station		BPC Date / %	
Rly / Divn. -		BPC No	
CC /Pm /End to end		Air/Vacuum brake	

### **Driver's particulars / (Train Engine & Banker)**

Driver's Name		HQ	
Qualification		Safety Category	
Date of Appointment		Nominated LI	
Guard's Name		HQ	

### **Affected & Adjacent Wagon's Particulars**

Sr. No.	Wagon No.	Class	Rly	R / Date	POH	ROH	Position from Loco
1							
2							

Screw coupling / CBC (Alliance II / AAR-HT):

Bearing: 16T RB / 20T RB / 20.3 T CTRB:

**Whether empty / loaded —**

### Observations Recorded by CWI/SSE/SE(C&W) for CBC Uncoupling

<b>SN</b>	<b>Components</b>	<b>Affected Wagon</b>	<b>Adjacent Wagon</b>
<b>A</b>	<b>CBC Uncoupling lever handle</b>	----	----
01	Over all length in straight line (Centre of hook to centre of rod) <b>Std. 1414 mm, for BLC- 1063 mm</b>		
02	Total length of bent end ( <b>Std. 400 mm</b> )		
03	Geometry of CBC uncoupling lever handle ( <b>Straight/Bent</b> )		
04	Anti rotational lug size ( <b>210 mm long, cross section 16X16 mm</b> )		
05	Condition of uncoupling lever handle bracket & additional bracket		
<b>B</b>	<b>Bearing piece</b>	----	----
01	Slot gap in the bearing piece ( <b>Std. 17.5 mm</b> )		
02	Bearing piece pin ( <b>Bent/Straight</b> )		
03	Bearing piece pin secured with proper washer/Nut or not		
04	Bearing piece pin dia ( <b>Std. 24 mm</b> )		
<b>C</b>	<b>CBC Knuckle, Coupler &amp; Fittings</b>	----	----
01	Dropping of locking piece to proper depth & Toggle is seen.		
02	Gap between knuckle nose & guard arm to be checked by <b>gauge No.2</b> first and then with <b>gauge No.1 ( Max. gap 133 mm)</b>		
03	Wear of the knuckle to be checked with gauge No. 3 ( <b>Within limit/Beyond permissible limit</b> )		
<b>D</b>	<b>CBC Drooping</b>	----	----
01	CBC height from centre of track ( <b>Std. Min.1030 mm &amp; Max. 1105 mm</b> )		
02	CBC Shank wear plate ( <b>Worn out/Missing or OK</b> )		
03	CBC Striker casting wear plate ( <b>Worn out/Missing or OK</b> )		
<b>E</b>	Condition of Knuckle thrower ( <b>Worn out/Missing or OK</b> )		
<b>F</b>	<b>Lock lift assembly</b>	----	----
01	Condition of lock & its slot for free movement of toggle pin. ( <b>worn out or OK</b> )		
02	Condition of toggle ( <b>Worn out/Missing or OK</b> )		
03	Condition of both rivets ( <b>Worn out/Missing or OK</b> )		

<b>SN</b>	<b>Components</b>	<b>Affected Wagon</b>	<b>Adjacent Wagon</b>
04	Condition of Auxiliary Anti-creep lug ( <b>Worn out or OK</b> ). The condition to be checked <b>by pressing rotary lever with the help of thumb towards striker casting to enter in the bottom cavity of CBC body (Through which toggle enters) without operating/Touching CBC operating handle</b> . If it goes in that, indicates anti-creep protection failure, in that case, necessary repairs to articulated assembly be ensured on the wagon.		
05	Whether toggle is seen properly when CBC lock piece is in fully dropped condition and CBC in locked condition.		
<b>G</b>	<b>Any other observations:</b>		
<b>H</b>	<b>Conclusion:</b>		
<b>I</b>	<b>Responsibility</b>		
<b>J</b>	<b>Repercussion</b>		

**Signature** :

**Name of CWI/SSE/SE(C&W)** :

**Depot** :

## Check List for Reporting Hot Axle on Wagon Stock

Train No./ Loco No./Base shed of Loco	
Load/Tonnege	
Last Exam station /Date/% / BPC No./(CC/PM/Int)	
Wagon No./Class/ Rly.	
Last POH Workshop / Date	
Last ROH station/Date :	Return date:
Commodity :	Loading station :
weight of contents	
Position of wagon from engine	
Position of affected wheel	
Type of bearing-22.9 T./20.3 T/ CT RB	
Make of Bearing & year of Manufacture	
Latest UST particulars stamped/ punched	
Axle Particulars	
Return date stamped on backing ring of Bearing	
Rotation of Axle box (Free / Jam )	
Condition of Rollers (Damaged / seized)	
Condition of Outer race (Broken / Damaged)	
Condition of Inner race (Broken / Damaged) /	
Condition of grease	
Condition of grease seal	
Condition of Locking studs (loose /deficient)	
Condition of Locking plate	
Any symptoms of brake binding	
Flat places /Skidding of wheels (size of flat if any)	
Any other unusual occurrences on bogies which could have prevented free rotation of bearing.	
Any other unusual noticed (EM pad / Adapter)	
Probable cause of failure	
Responsibility	
Spring height	
Weight	

## **Check List for Inspection of In-Motion Weigh-bridges (Once in 03 Months)**

by team of JA Grade, Senior Scale and Jr. Scale Officers from Operating, Commercial Mechanical, Civil, and Finance Department for proper functioning and follow up of proper procedure.

**[ Ref: Railway Board's letter No. TC-1/2004/109/4 dated. 04.11.2004 ]**

SN	Description of Items to be checked	Remarks	Additional Remarks if any
1.	Availability of Certificate of Stamping & verification issued by Weight and Measures Department of State Government.	Available / Not available	
2.	Availability of breakdown register showing date and time the weigh bridge went out of order, put back into commission, problem reported, remark of service Engineer with signature of Weigh Bridge in charge and nominated mechanical official.	Available / Not available	
3.	Digitizer and control panel should be locked and sealed.	Yes/No.	
4.	Locking of weigh bridge room when not in use.		
5.	Locking of junction boxes.		
6.	Locking of all doors provided on cubical/cabinet of control equipments and putting paper seal with date of seal, duly signed by weigh bridge in charge and suppliers service engineer.		
7.	Weighment readings recorded at speed less than 15 kmph.	Yes/No.	
8.	Rakes to be moved through weigh bridge with uniform speed below 15 kmph without any acceleration / deceleration.		
9.	No electric connections taken from junction box provided between UPS and weigh bridge computer, digitizer etc.		
10	Working of Diesel generator set.	Working / Not Working	
11.	Weigh bridge is under Annual Maintenance Contract or otherwise.	Yes/No.	
12.	Testing of Weigh Bridge is done as per procedure and within duration laid down.	Yes/No.	
13.	Rakes for movement should be moved through Weigh Bridge without stopping short of Weigh Bridge.		
14.	Weighment to be made in pulling mode only.		

## Appendix-VIII Check lists for Inspection of wagon stock

SN	Description of Items to be checked	Remarks	Additional Remarks if any
15.	Availability of 'Weigh Bridge Ahead' board on both sides about 300m in advance of Weigh Bridge.	Yes/No	
16.	Track upto 100 m on either side of Weigh Bridge should be level tangent.		
17.	Approach rail of 52 kg/m with PSC sleepers should be available.		
18.	The track should have adequate ballast cushioning and proper drainage.		
19.	Creep Anchors should be provided to take care of possible creep.		
20.	Proper maintenance of weigh cabin/control room such as cleanliness, whitewashing, good condition of window and doors shall be ensured.		
21.	Availability of water connection is to ensured for wetting of earth pit.		
22.	Two separate 230 V.AC supply points of adequate capacity, one for weigh bridge equipment and other for AC & lighting load in Weigh Bridge shall be provided.	Available / Not Available	
23.	Standby power supply arrangement through Diesel generating set is to be made available.	Available / Not Available	
24.	Provision of earthing and its maintenance as per 153043-1966 shall be ensured and earth resistance & its continuity shall be subjected to annual checks.		
25.	UP Keep of electrical equipments such as lights, fans and AC unit provided inside the weigh room and also in the general area around the weigh rails and track side switches for security reasons.		
26.	The AMC of the associated electrical equipment viz. UPS, air-conditioner, voltage-stabilizer etc. necessary for proper operation of the weigh bridge.		
27.	S&T department shall maintain the jumpers for the track circuit wherever provided by passing the weigh rails.		
28.	RDSO type block joints shall be provided and maintained on both sides of the weigh rails to provide electrical isolation of weigh rails.		
29.	Inspector / RPF In charge of the area shall exercise the necessary superintendence for the security of the weigh bridge ensuring general security of the weigh bridge installation.		

Sr DCM

Sr DOM

Sr DME

Sr DEN

Sr DFM



**CHECKLIST FOR ANALYSIS OF BP AIR HOSE UNCOUPLING**

<b>SN</b>	<b>Description</b>	<b>Std.dimensions</b>	<b>Remarks</b>
01	Whether the length of Rubber hose is 660 mm	660 mm	
02	Whether the length of complete BP air hose( including palm & nipple) is 835 mm	835 mm	
03	Condition of crimped clamps & their availability at both the ends of rubber hose	--	
04	Condition of check nut on nipple and its availability	--	
05	Condition and availability of MU washer	--	
06	Condition of palm locking pin and its diameter in mm.	--	
07	Condition of palm lugs. Check for worn out lugs	--	
08	Check for any dashing/scratch marks on the bottom of palm ends	--	
09	Check make of air hose and stamping particulars	--	
10	Whether BP hose found torn, twisted or normal	--	
12	Check geometry of BP Metallic pipe for proper positioning.	--	
14	Check worn out palm end lug edges and leakage of air	--	
15	Check position of ball lever of coupling in case of coaching stock	--	
16	Screw coupling ball lever modified or not in case of coaching stock	--	
17	Ensure correct fitting of BP air hose with angle cock.	--	
18	Ensure correct fitment of spare screw coupling in suspension hook in case of coaching stock.	--	
19	Any ballast unloading is observed in the section where air hoses uncoupled.	--	
20	Ensure condition of Nipple of BP air hose for worn out threads.	--	
21	Ensure condition of angle cock for worn out threads.	--	

**Signature** :  
**Name** :  
**Depot** :

**CHECK LIST FOR REPORTING FLAT TYRE**

( Wagon/Coach No. ....Train No.....Date.....)

SN	Description	Remarks		
01	Date			
02	Division			
03	Station / section of unusual			
04	Train No.			
05	Load			
06	Loco No.			
07	Loco Pilot			
08	Train coming from			
09	Stock: ( CC/PM/End to end )			
10	Last examination station/Rly/Date			
11	Wagon No.			
12	PRO Particulars	POH	ROH	R/date
13	Validity of BPC & BPC No.			
14	Brake Binding reporting station: (Reported by ASM, Gateman, Driver, Guard, PWI & Other)			
15	Flat tyre reporting station: (Reported ASM, Gateman, Driver, Guard, PWI & Other)			
16	Detaching station / section			
17	Size of Flat in mm (Max. 50 mm for coaching stock & Loco) (Max. 60 mm for Wagon stock)			
18	Cause of flat tyre (DV/SAB/Bad Engineman ship /BC, etc.)			
19	Check for shelled tread wheels			
20	Check metal deposition on wheels			
21	Cattle run over if any			
22	Loco change if any			
23	Attaching / Detaching at station			
24	Signal on approach			
25	Caution order in previous section			
26	Hand brake 'On'/'Off'			
27	Position of Empty/loaded box handle			
28	Functioning of LSD in case of BLC			
29	Condition of Brake system. (DV isolated / working/any other detail)			
30	Check proper functioning of brake gear pin suitable to wheel diameter.			
31	Check end pull rod hole position is correct or not ( according to dia of wheel)			
32	Detailed cause of flat tyre (i.e. exact cause of DV/SAB/Brake Cylinder etc.)			

## Appendix-VIII Check lists for Inspection of wagon stock

SN	Description	Remarks
a.	<b>Check A” dimension</b> 70+2-0 for air brake stock other than BOBRN 27+2-0 for BOBRN wagons	
b.	Check “E” dimension 575±25 mm for wagons	
c.	Check “A” dimension 22+2-0 mm for <b>Coaching</b>	
d.	Check “E”dimension 375±25 mm for <b>Coaching</b>	
e.	Check Piston Stroke 60- 70 mm for (Modified) & 32-40 mm for BMBC <b>Coaching</b> stock	
f.	Check releasing time of wagon/Coach	
g.	Check Sensitivity/Insensitivity of DV	
h.	Check whether brake cylinder releasing or not	
i.	Check hand brake for brake application	
j.	Check functioning of SAB ( Pay-in/Pay-out is smooth or not	
k.	Check SAB pull rod for correct length	
l.	Type of brake block (composite /cast iron)	
	<b>Additional information:</b>	
33	Make of DV & Stamping particulars	
34	Date of manufacturing of DV	
35	Last POH date of DV	
36	Make of SAB & Stamping particulars	
37	Date of manufacturing of SAB	
38	Last POH date of SAB	
39	Check Brake cylinder make & Stamping particulars	
40	Make of Brake block	
41	DV/SAB test report from BSL/ET	
42	Any other detail	
43	<b>Conclusion:</b>	

Date :

Name of the Officers :

Depot:

Designation :

## Check List for Wheel Impact Load Detector ( WILD)

SN	Description	Status
01	<p><b>Purpose and capability:</b> The wheel impact load detector system is capable of automatic detection of defective wheel of rolling stock by measuring vertical impact load on the rails. The system is also capable of detection of over loaded wagons, speed of train &amp; generation of automatic exception report. Check all aspects</p>	
02	<p><b>Scope of supply:</b> The specification covers manufacture, supply, installation and commissioning of 36 channel wheel impact load detection system with signal processor, 02 nos. instrumented rails of 52/60Kg. with length of 13 M each and other accessories. Check installation as per scope.</p>	
03	<p>The wheel impact load detection system is supplied on Turnkey basis which consists of construction of one room of size 4.0MX3.0MX3.0M for housing computer, control electronics, data acquisition system and air conditioner. This should be ensured as per standard specifications.</p>	
04	<p><b>Specific characteristics:</b></p> <ol style="list-style-type: none"> <li>01. The system is comprising of 36 Channels system. 34 will be used for detection of impact load &amp; 2 are utilized for activation of system. To be checked.</li> <li>02. For detection of impact load, each channel comprises of 4-resete type Strain gauge fixed on rail. Condition to be checked.</li> <li>03. The system detects defective wheels of 770 mm to 1100 mm diameter by measuring impact load on rails.</li> <li>04. The system will work effectively in the speed range of 30 KMPH to 160 KMPH. Check effectiveness at suitable speed.</li> <li>05. The system will measure impact load up to 60 Tonnage or more for the complete speed range of measurement.</li> <li>06. The system is capable of detecting 95% or more defective wheels on first pass, to be checked.</li> <li>07. The system is capable of functioning with trains consisting up to 100 vehicles(400 axles), to be checked.</li> <li>08. The system shall have 3 levels of alarm ranging from 3 to 30 T &amp; emergency alarm for loads higher than 30 t, this aspect should be checked.</li> <li>09. The interconnection of both computers i.e. at site and remote control is through DOT telephone line of optical fiber cable. The provision between site and control is provided by Railways, its connectivity to be checked.</li> <li>10. Software is able to generate the reports with following items <ol style="list-style-type: none"> <li>a. Date of run</li> <li>b. Time of train passing</li> <li>c. Run No.</li> <li>d. Trains name &amp; No.</li> <li>e. Axle no. from front</li> <li>f. Average normal dynamic wheel load</li> <li>g. Maximum dynamic wheel load</li> <li>h. Impact load factor</li> <li>i. Speed of each axle</li> <li>j. Overloaded wheel details</li> </ol> </li> </ol>	

## Appendix-VIII Check lists for Inspection of wagon stock

	<p>k. Speed of Trains l. 03 level alarm generation. Printed reports to be checked for ensuring above parameters.</p> <p>11. The system is rugged and temper proof so as to work round the clock through out the year in harsh and dusty out door environment exposed to sun. Any abnormality to be checked.</p>	
5	<p><b>Site Condition:</b> Whether the system is installed on straight and level track of minimum 250 m length including approaches to the site.</p>	
6	There shall be no fish plated joint within 13 on either side of the instrumented portion of the track.	
7	The rail section shall be 52 Kg/m or 60 Kg/m with flat foot laid on Pre-stressed Concrete (PSC) sleepers at 60 cm to 65 cm spacing with elastic fastenings viz. pandrol clips on rubber grooved sole and clean ballast cushion 300 mm	
8	The site shall not be very close to any station or at the approach of a signal to avoid acceleration or braking over the instrumented rails.	
9	<p><b>Training:</b> Whether technical experts of the manufacturer has given full and adequate 03 days training to the operators and maintenance staff nominated by the consignee during commissioning of machine.</p>	
<b>Other facilities:</b>		
10	Availability of Drinking water facility	
11	Security arrangement by RPF.	
12	Condition of Telephone line or optic fibre for better connectivity of system at site to the remote control room.	
13	Availability of Power Supply 230 V. $\pm$ 10%, 50 Hz up to room & Earthing arrangement.	
14	Quality of construction of one room of size 4.0MX3.0MX3.0M for housing computer, control electronics and data acquisition system, air conditioner.	
15	Whether approach road is available or not to the site.	
16	There will be no any welded joint in the instrumented portion of the rails.	
17	Track condition should be as close to new-condition of track as possible.	
18	Rail head profile should be relatively new and sleeper/ballast interface should be stable.	
19	Rail head use for instrumentation should be ultrasonically tested and to be defect free.	
20	Whether AMC visits are being done timely by the Firm's representative, check maintenance schedule forms.	
21	Check record of Incidences/defects and action taken by nearest TXR point to avoid running of defective Wagon/Coach/Loco.	
22	<b>Any other problem</b>	

Date :  
Depot:

Name of the Officers :  
Designation :

## **CHECK LIST FOR INVESTIGATION OF BRAKE BINDING**

### **1 General Particulars:**

Date		Time	
Division		Section	
Caution order		Block section	
Weather condition		Km No.	

### **2. Train particulars:**

Train no.		Loco no.	
Load		Banker no.	
BPC no.		Last examination station	
PM/ CC/End to End		CC+6 / CC+8	

### **3. Particulars of Driver:**

Name		HQ	
Date of appointment		Date of promotion	
Safety category		Last PME	
Involved in Train parting / Accident in last two years			
Details of Ghat Driver		-	
Guard's name		HQ	

### **4. Particulars of affected wagons:**

Wagon no.		Type	
Built date		POH	
ROH		R/D	
Position from loco		Type and condition of brake blocks	
Whether empty / loaded		Consignment loaded	

### **5. Type of DV and make :**

Make		Last overhauling	
Sr. no.		-	
Charging time		Releasing time	
Any leakage from DV		-	

### **6. Brake binding reporting:**

Station	
Reported by (Dy. SS/Gateman/Guard/ Driver/ Points man/C&W staff of any other)	
Reporting time	

**7. Other information**

Whether <b>cattle run over</b>	
Any <b>Loco changed</b> enroute	
Any <b>shunting carried out</b> enroute	
<b>Signals</b> on approach	
Any Caution order observed before brake binding	
Any <b>air leakage</b> on train	
Condition of <b>Hand brake</b>	
Position of <b>empty load box</b> change over lever	
Functioning of <b>load sensing device</b> in case of BLC/BLL/BCC/BOBRN (Any leakage from VTA valve)	
<b>Condition of Air brake equipments</b>	
a) <b>Working of DV</b> (Working / Isolated)	
b) <b>Brake cylinder</b> (Working / any leakage/ Piston sticky)	
<b>c) Piston stroke:</b> 60-70 mm for modified & 32-40 mm for BMBC <b>Coaching stock</b> 130 $\pm$ 10 mm for loaded BOX-N/BCN <b>wagons</b> & 85 $\pm$ 10 mm for empty	
d) Condition of <b>SAB</b> (Working / Not working)	
<b>e) 'A' dimension:</b> 70 $\pm$ 2-0 mm for air brake stock other than BOBRN 27 $\pm$ 2-0 mm BOBRN <b>wagons</b> 22 $\pm$ 2-0 mm for <b>Coaching stock</b>	
<b>f) 'E' dimension:</b> 575 $\pm$ 25 mm for <b>wagons</b> 375 $\pm$ 25 mm for <b>coaching</b>	
<b>Brake gear system</b> (standard / non standard pins fitted or related parts missing)	
<b>End pull rod hole</b> position with respect to wheel diameter(Correct /Incorrect)	
Any application of <b>emergency braking</b> during run	
Whether driver did brake feeling test at first opportunity and <b>given Releasing time</b> to release the train fully.	
Whether complete train was released or not after <b>Traction change</b> , if any.	

**Brief History:****Statement of Loco pilot:****Statement of Guard:-****Analysis:** 1.

2.

**Conclusion:****Responsibility:****Repercussion:**

**APPENDIX – IX**

**OPERATION AND MAINTENANCE**  
**OF**  
**BOGIE COVERED DOUBLE DECKER WAGON**  
**TYPE "BCACBM"**



**GENERAL:**

This Annexure contains instructions for the maintenance and operation of Bogie Covered Double Decker Wagon Type "BCACBM". The Broad Gauge Bogie Covered Autocar carrier wagon to diagram drawing No.-WD-11013-S-01 has been developed by RDSO for transportation of automobile cars. A rake of these wagons consists of 3 units; each unit consists of 9 wagons - 2 nos. wagon 'A' & 7 nos. wagon 'B'. Both 'A' and 'B' wagons have twin decks to accommodate cars. The upper decks of both wagons are movable to accommodate different heights of cars by diamond screw jack arrangement fitted in the wagon. Wagon-'A' is fitted with CBC couplers on both ends with the coupler at one end at a designed height from rail level as 1105mm, the other end incorporates CBC at a lower height of 861mm. Wagon-'B' is fitted with CBC couplers on both ends at a designed height from rail level as 861mm. Each unit shall be moved as one entity and the movement of individual wagon (i.e. Wagon-'A' and Wagon-'B') shall not be done. The design incorporates LCCF-20 (C) bogie with speed potential of 100 kmph and single pipe graduated release air brake system. This wagon is fit to run up to a maximum permissible speed of 100 kmph in empty and 95 kmph in loaded condition.

The movement of the wagon on the Indian Railway network shall be governed by the RDSO Final Speed Certificate No. MW/BCACBM dated 27.02.2013 and its amendments issued from time to time.

## CONTENTS

<b>Para No.</b>	<b>Descriptions</b>	<b>Page No.</b>
<b>1.</b>	<b>Scope</b>	4
<b>2.</b>	<b>Leading Particulars</b>	4
<b>3.</b>	<b>Overhaul, Inspection and testing (Maintenance schedule)</b>	5
<b>3.1</b>	<b>Trip examination</b>	5-6
<b>3.2</b>	<b>Routine Overhaul</b>	6-8
<b>3.3</b>	<b>Periodic Overhaul</b>	8-10
<b>4.</b>	<b>Facilities required for POH and ROH</b>	10
<b>5.</b>	<b>Operation</b>	11-12
<b>5.1</b>	<b>Opening and closing of end doors and end flap doors</b>	11
5.1.1	At the time of loading originating stations	11
5.1.2	At the time of unloading terminating stations	11
<b>5.2</b>	<b>Movement of middle decks</b>	11-12
5.2.1	Upper Deck height adjustment	11
5.2.2	Upper Deck locking and unlocking	11
5.2.3	Safety precautions	11-12
<b>5.3</b>	<b>Check list before ready for loading of automobile cars</b>	12
<b>5.4</b>	<b>Loading and Unloading</b>	12
5.4.1	Placement of ramp	12
5.4.2	Sequence of loading and Unloading automobiles	12
5.4.3	Movement of Vehicles	12
<b>5.5</b>	<b>Lashing/securing</b>	12
<b>6.</b>	<b>Marshalling</b>	13
<b>7.</b>	<b>List of construction drawings</b>	13-14
<b>8.</b>	<b>List of components used in BCACBM wagon, not generally used in other wagons</b>	14
<b>9.</b>	<b>Proforma for SWTR</b>	15

**1. SCOPE:**

These maintenance instructions are for Broad Gauge Bogie Covered Autocar carrier wagon type "BCACBM" to diagram drawing No.-WD-11013-S-01 designed by RDSO for transportation of automobile cars and does not apply to any Automobile Car Carrier Wagon owned by Railways or private parties.

**2. LEADING PARTICULARS:**

PARTICULARS		Wagon-A	Wagon-B
2.1.	Length over headstocks	22626 mm	22626 mm
2.2.	Length over coupler faces	23555 mm	23555 mm
2.3.	Bogie Centre	14345 mm	14345 mm
2.4.	Width over sole bars	2896 mm	2896 mm
2.5.	Inside width between side stanchion faces	2746 mm	2746 mm
2.6.	Overall width of roof	2900 mm	2900 mm
2.7.	Overall height from R.L.	4305 mm	4305 mm
2.8.	Height of CBC from R.L.	X-End 1105 mm Y-End 861 mm	Both Ends 861 mm
2.9.	Height of Lower deck floor from R.L.	X-End 1182 mm Y-End 938 mm	Both Ends 938 mm
2.10.	Height of movable upper deck floor from R.L. (in Step of 50mm)	X-End 1306-2006 mm Y-End 1550-2100 mm	Both Ends 1550-2100 mm
2.11.	Estimated Tare	35.860 T	35.720 T
2.12.	Pay Load	15 T	15 T
2.13.	Gross Load	50.860 T	50.720 T
2.14.	Number of wagons per rake	06	21
2.15.	Maximum number of cars per rake	318	
2.16.	Axle Load	12.715 T	12.680 T
2.17.	Operating Speed (Maximum)	Empty	100 kmph
		Loaded	95 kmph
2.18.	Material of construction for wagon body	IS:2062 E250A with Cu, IS:1079 Gr-'O', IS:4923-97, IS:513 Gr-'O'	
2.19.	Couplers	High tensile non- Transition	CBC to RDSO STR No. 48-BD-08
2.20.	Draft Gears	High Capacity Draft Gear to RDSO STR No. 49-BD-08	
2.21.	Bogie	LCCF Bogie to specification no. CONTR-LCCF20 (C)-96 <input type="checkbox"/> Wheel Base 2000 mm <input type="checkbox"/> Wheel Dia on Tread (new) 840 mm <input type="checkbox"/> Wheel Dia on Tread (worn) 780 mm <input type="checkbox"/> Axle load capacity 22T	
2.22.	Brake system	Single pipe graduated release air brake system. <input type="checkbox"/> Air Brake Equipment to RDSO STR No. 02-ABR-2002 <input type="checkbox"/> Air Brake Pipe and Pipe Joints to RDSO STR No. 04-ABR-2002.	

### 3. Overhaul, Inspection and testing (Maintenance Schedule):

In order to keep the wagon in good fettle, following schedule of maintenance are recommended:-

- a) Trip examination
- b) Routine overhauling (ROH)
- c) Periodic overhauling (POH)

The periodicity and the kilometerage of the various schedules shall be in accordance with the instructions issued by the Railway Board from time to time.

#### 3.1. Trip examination:

**3.1.1.** The trip examination for the BCACBM wagon at the originating and terminating stations shall be done at nominated "Base Depot". Since these wagons are generally to be run in unit train service, being a special commodity rolling stock, involving wagon to wagon transfer of commodity during loading/unloading shall make efforts to maintain the integrity of the rake.

**3.1.2.** The Incoming rake, after unloading of automobile cars at loading and unloading terminals, is required to be placed on maintenance lines for inspection and attention. The details of tentative examination and attention required thereon in general are listed below:

- i) All underframe fittings including brake gear, draw & buffing gear and running gear should be examined and made in sound condition with all fittings intact.
- ii) Wheels must be tapped to detect loose/cracked wheel.
- iii) The wheel profile should be checked to ensure that rejectable defects have not been allowed. Tyre Defect Gauge may also be used for this purpose.
- iv) The Air Brake system of the rake should be checked as follows:
  - a) Connect compressor line on stationary air compressor to one end of rake through a Rake Test Rig as per RDSO instruction G-97.
  - b) Charge the Brake Pressure of rake to  $5 \text{ kg/cm}^2$ .
  - c) Check and attend to the parts of Air Brake System components like Distributor Valve, Slack Adjuster (SAB), Brake Cylinder, Centrifugal Dirt Collector, Cut-off Angle Cocks, Auxiliary Reservoir, Hose Coupling etc as per manufacturer's manual/As per RDSO instruction G-97. Release condensates wherever collected in the Air Brake System.
  - d) Check the "A" Dimension of Slack Adjuster and set to dim.  $70 +2, -0 \text{ mm}$ . Adjust the pins in the pull rod holes if required. Due corrections and repairs to be made for ensuring 100% Brake Power.
  - e) Record reading as per proforma specified at page 15 of this manual.
  - f) The piston stroke should be  $100 \pm 10 \text{ mm}$  in empty and loaded condition.
- v) The general conditions of underframe, bogies, side bearer assembly etc. should be examined and repairs attended to.
- vi) Check all safety fittings, safety brackets etc and defects if any attended to.
- vii) Inspect hand brake system for proper functioning.
- viii) One bogie complete in all respect may be kept as spare to save time and power.
- ix) Inspection of all springs (side bearer and suspension).
- x) Visual inspection of Elastomeric pads for any defect.

- xi) Examine the wagon underframe and superstructure visually to identify distress, if any wagons found with distress makes that are unattendable in the yard should be marked sick and attended to in sick-line.
- xii) All end doors and flap doors to be properly and effectively secured in closed position.
- xiii) All screw jacks for operating the middle deck adjustment should be in disengaged position. Greasing of the jack spindle shall be carried out if required for ease of movement of middle deck.
- xiv) All middle decks of the wagon to be properly and effectively secured in locked position.
- xv) All the originating trains should be examined by train examining staff before despatch to ensure that the wagons are in a fit condition and do not have any rejectable defects. The rejectable defects are those defects covered by IRCA Manual such as defective/broken parts of running gear, draw and buffing gear, Elastomeric pads, springs, side bearer arrangement, air brake system, wheel and axle assembly, automatic locks etc. It is to be noted that a certificate has to be given to the yardmaster by the TXR to this effect without which the trains cannot be despatched
- xvi) The level of Air pressure on the Engine and the brake van along with the percentage of effective brake power must be recorded on the brake power certificate and countersigned by the driver and the guard. Preferably 100% brake power should be ensured at the primary maintenance station. One Car may be allowed to have a dummy (ineffective) brake cylinder on en-route/return trip.
- xvii) Before loading and unloading, the wagons shall be visually examined by the representative of automobile car company to be ensured that the requirements of deck heights for safe loading and unloading of automobile cars.

### **3.2. Routine overhauling (ROH):**

- 3.2.1.** A first routine overhaul should be given to all wagons as a unit of 9 wagons (Wagon A-2, Wagon B-7) at the nominated depot.
- 3.2.2.** Disconnect 9 wagon units into separate individual wagon. Each wagon requires to undergo ROH individually. The important points generally to look into is given below for ready reference. Other details of RDSO standard ROH procedure should also be followed.
  - (1) Remove bogie brake rigging attachments to underframe, brake gears & flexible pipes connections.
  - (2) Remove center pivot split pin, lock pin & shackle lock etc.
  - (3) Lift the body through lifting pads.
  - (4) Run out the bogie.
  - (5) Place the structure complete on trestles.
  - (6) Visually inspect the structure of the wagon if found any defects like welding cracks, sidewall stanchion deformations, corroded side panel, roof profile deformation, locking of upper decks, locking of end doors, locking of flap doors, door hinge , missing of door hinge pins etc which shall be rectified and dimensions will be maintained as per RDSO drawings listed with this manual.

- (7) Visually inspect the structure of the upper deck, maintain the camber along width, if lost, check clearances of all deck guide rollers with roller guide pressing and maintain per drawing no WD-11013-S-05. Checks the workings of all screw jack arrangement provided in the wagon and make sure the proper functioning of lifting arrangements for middle deck. Also check locking arrangement of deck with side stanchions and make sure for proper functioning of locking arrangement.
- (8) After removing the side frame key and lifting the bogie remove wheel sets from the bogie. Machine the wheel tread of all the wheels to new wheel tread profile.
- (9) Strip the bogie. After proper cleaning, examine the bogie side frames, bolster and other castings for cracks, wear surface etc.
- (10) All the side bearer liners of the slide block and side bearer seat should be replaced.
- (11) Checks bolster springs & side bearer springs for defective/broken springs. Replace the defective one such that variation in the height of springs in the same group not to exceed 2mm
- (12) Examine centre pivot, centre pivot pin, centre pivot liner, side bearer liner & side bearer springs.
- (13) Strip brake gear fittings and examine for wear & damage and serviceability bogie brake gear levers. Replace worn-out bushes & pins, brake blocks and repair worn out brake heads.
- (14) The attention and repair of bogie and its components should be done as per chapter "CAST STEEL BOGIE TYPE LCCF 20 (C)-96" of 'Maintenance Manual of Bogie Container Flat wagon type BLCA/BLCB' (latest revision) issued by RITES.
- (15) Thoroughly inspect axle boxes externally for any sign of defects such as grease leaking out, visible sign of damage or seized bearing. Rotate axle box by hand to see that it revolves freely and smoothly Defective wheel sets on this account should be sent to POH shop for repair. Check adapter & replace if found any defect.
- (16) Examine underframe brake gear levers; replace worn-out bushes & pins.
- (17) Examine slack adjuster (SAB) and replace or attend to the defects as per RDSO instruction G-92. After fitment set the SAB "A" dimension 70 +2, -0mm.
- (18) Examine all draft & Buffing gear, CBC, uncoupling gear etc. Attend to defective or worn-out parts as per RDSO instructions G-76. Examine Draft Gear and replace the defective one. Dimension 25mm clearance of the wedge block on the Yoke should be maintained.
- (19) Check-up Hand Brake arrangement for repair. Replace the missing or damaged parts. Lubricate the gears.
- (20) Lower the under frame on bogies and provide pivot pin shackle, pin with split pin. Check the C.P assembled height which should be in the range of 71mm to 73mm.
- (21) Dimension  $66 \pm 3$ mm between underframe bolster bottom plate to bogie side frame top should be maintained.
- (22) Test air brake as per RDSO instruction G-97.

- (23) Check the distance from Side Frame top liner to Side Bearer Seat 131 +0, - 0.5 mm at all four Side Bearer points under tare condition of the Flat Wagon. Keep the distance within tolerance by altering Shims provided at the top side bearer locations.
- (24) Paint the bogie, stencil station code & date of ROH.
- (25) Touch up paint & lettering if required as per RDSO drawing no. WD-11013-S-26.
- (26) Special instruction: The CBC height should not be more than 861mm on both end of Wagon-B, 1105mm on X-end of wagon-A and 861mm on other end of Wagon-A. No packing be given over axle box adapter for CBC height adjustment.
- (27) All items of Air brake equipment to be ROH as per instructions laid by RDSO instruction G-97.

### **3.3. Periodic overhauling (POH):**

- 3.3.1.** All items of ROH attention shall be attended to in POH.
- 3.3.2.** The general procedure laid down for POH of BOXN and other wagons are applicable to these wagons. As these wagons are as module/unit of 9 wagons containing 2 Wagon 'A' and 7 Wagon 'B', the BCACBM wagons may be sent to nominated wagon repair shops for POH in a complete module/units so that the shops can turn out the wagons as modules/units for service.
- 3.3.3.** The unit will be disconnected and maintenance and repairs as individual wagon carried out as per routine POH method.
- 3.3.4.** The important aspects, which require particular attention, are given below:

#### **3.3.4.1. Bogie Shop:**

- (1) The procedure for attending the repairs of bogie frames, bolster and liners are maintained as per chapter "BOGIE Type LCCF 20 (C)" of Maintenance Manual of Bogie Container Flat wagon latest revision.
- (2) Dismantle the bogies, replace the pins and bushes in brake gear, check the side frames and bolster etc. for any defect. Attend or replace as necessary.
- (3) All the side bearer liners of the slide block and side bearer seat should be replaced.
- (4) Check the springs and replace the defective ones. All the springs are required to be tested as per load test chart.
- (5) Check the side bearer parts, centre pivot and its liners. All liners including centre pivot liner need replacement.
- (6) All brake gear components should be dismantled, cleaned and necessary repairs are to be carried out. All pins and bushes require renewal.
- (7) Attend to wheel sets for new tread profile. All Roller Bearings need thorough attention.
- (8) Assemble the bogies and check for leading dimension and tolerances.

- (9) Side Bearer Springs may be replaced if the heights under load testing of individual springs are not within specified limits.

#### **3.3.4.2. Complete structure and Assembly Shop:**

- (1) Place the Complete structure on trestles.
- (2) Under frames should be wire brushed, or shot blasted & cleaned and checked for any member being defective due to welding defects, etc. and defects are attended to before primer coat paint.
- (3) All stiffeners, strengthening pieces, side stanchions, end doors and flap doors etc. checked for defect and repair to be carried out.
- (4) Visually inspect the structure of the wagon if found any defects like cracks in underframe, welding cracks in any structural members, sidewall stanchion deformations, corroded side panel, roof profile deformation, locking of upper decks, locking of end doors, locking of flap doors, door hinge, missing of door hinge pins etc. shall be rectified and dimensions will be maintained as per RDSO drawings listed with this manual.
- (5) Visually inspect the structure of the upper deck, maintained the camber if lost, clearances of deck guide rollers with roller guide pressing as per drawing no WD-11013-S-05. Checks the working of all screw jack arrangement provided in the wagon and make sure the proper functioning of lifting arrangements for middle deck. Also check locking arrangement of deck with side stanchions and make sure for proper functioning of locking arrangement.
- (6) Check all deck guide rollers if found worn out replace them as per Item no.-7 and 8 of RDSO drawing no WD-11013-S-05.
- (7) Visually inspect the stanchions and measure the distance between sides stanchion at two locations i.e. bottom and top of all stanchions of the wagon and maintain straightness of side stanchions for proper movement of upper deck.

#### **3.3.4.3. Air Brake equipment:**

- (1) Air Brake equipment are attended to by replacing all rubber items & defective parts, as per instructions laid by RDSO instruction G-97.
- (2) Clean the strainers & drain the water and dirt etc. in dirt collectors, Auxiliary Reservoir, etc. Attend to air brake as per instructions laid by RDSO instruction G-97.
- (3) Remove SAB, dismantle and change the worn-out parts, grease the items inside and attend to as per RDSO instructions G-92 to the extent applicable.

#### **3.3.4.4. CBC and Draft Gears:**

- (1) Dismantle & attend to worn-out parts by replacing/attending to the defects in components draft gear, coupler body, yoke, yoke pin, wear liner on coupler body and striker casting, uncoupling gear etc. as per RDSO instructions G-80.
- (2) Examine all draft & Buffing gear, CBC, uncoupling gear etc. Attend to defective or worn-out parts as per RDSO instructions G-76.



- (3) The CBC height should not be more than 861mm on both end of Wagon-B, 1105mm on X-end of wagon-A and 861mm on other end of Wagon-A. No packing be given over axle box adapter.

#### **3.3.4.5. Paint Shop:**

Painting & marking of station code, POH date, Base Depot, return date etc. shall be followed as per RDSO marking diagram drawing No.WD-11013-S-26 with latest alteration for both wagons. After painting and marking sufficient drying time should be allowed between each coat.

#### **4. Material Handling Equipment/Facilities Required For ROH Depot:**

1. Material Handling Equipment Facilities Required are given as below:
  - i) Overhead cranes 15 t capacity : 2Nos.
  - ii) Power Operated lifting Jacks 25 t capacity : 5Nos.
  - iii) Fork Lifts 5 t capacities : 3Nos.
  - iv) Hydraulic Jacks 25 t capacity : 4Nos
2. Other facilities like SAB repair shop, Air Brake repair and Overhaul shop, CBC, Machine shop, Stores etc need be provided. The repair in shop/ROH depot of these items will be as is the practice for other air brake bogie stocks.

## 5. Operation:

### 5.1. Opening and closing of end swing doors and end flap doors:

**5.1.1. At the time of loading/originating stations-** At the time of loading at originating stations, first of all end swing doors shall be opened and hooked on side wall as per provision given in sidewalls, thereafter all lower deck end flap doors shall be opened. After adjustment of required deck height for loading as per requirement, all upper deck end flap doors shall be opened. After successful loading of automobile cars, first all End Flap doors shall be closed, thereafter End Doors shall be closed and locked properly.

**5.1.2. At the time of unloading terminating stations-** At the time of unloading at terminating stations, first of all end swing doors shall be open and hooked on side wall as per provision given in sidewall then all upper deck's and lower deck's end flap doors shall be open. After unloading of automobile cars from all upper deck close the End Flap doors of upper decks, adjust the required deck height for unloading from lower deck at all X-end of Wagon-A as per requirement. After successfully unloading of automobile cars, first of all End Flap doors of lower and upper deck shall be closed and after all End Doors shall be closed and secured properly.

### 5.2. Movement of middle decks:

**5.2.1. Upper deck height adjustment:** At the time of loading/unloading at originating/terminating stations, after opening of swing and lower flap doors, before adjustment of required deck height, unlock the upper deck **after engaging the screw jack with upper deck**. Now required upper deck height can be obtained by means of screw jack arrangement provided within the wagon with the help of ratchet wrench or any battery operated torque wrench.

**5.2.2. Deck locking and unlocking:** At the time of loading/unloading at originating/terminating stations, after adjustment of required deck height all upper decks should be locked properly by locking arrangement provided in upper decks.

**5.2.3. Safety precautions:** Following safety precautions shall be taken during the movement of upper deck height adjustment:

- i) Before adjustment of required deck height and unlocking of upper deck, it must be ensured that screw jacks are engaged with upper deck to prevent accident.
- ii) After engagement of screw jacks, unlocking of upper deck with side stanchions should be ensured before starting movement of upper deck through the screw jacks.

- iii) After adjustment of desired deck height all decks must be locked and ensured before loading of automobile cars.
- iv) Disengage screw jacks with upper deck.
- v) Care may be taken during the opening and closing of end flap doors. It must be ensured that the end flap doors are properly in locked position at the time of movement of upper deck operation to prevent accident.

**5.3. Check list before ready for loading of automobile cars:** Following check list shall be followed by user before loading/unloading of cars:

- i) End swing and flap doors of all wagons in the rake must be opened.
- ii) All upper decks must be in locked position after adjustment of desirable height of deck through the rake.
- iii) Readiness of ramp at required height to be ensured for lower as well as upper deck.
- iv) For Loading and unloading availability of straight track may be ensured for better result.

#### **5.4. Loading and Unloading**

**5.4.1. Placement of ramp:** Place the ramp as per desirable height provided by wagon owners/automobile car transporter Company.

**5.4.2. Sequence of loading and Unloading automobiles:** Following sequence of loading and unloading shall be followed by wagon owners/automobile car transporter Company:

- i) At the time of loading first of all, after placement of ramp to lower deck, loading of cars in all lower decks will be carried out after placement of ramp with upper deck, loading of cars in all upper decks will be carried out.
- ii) At the time of unloading first of all, after placement of ramp to upper deck, unloading of cars in all upper decks will be carried out. Then after placement of ramp with lower deck, unloading of cars in all lower decks will be carried out.

**5.4.3. Movement of Vehicles:** For movement of vehicles para no.5.4.2 shall be followed and also ensured that movement of vehicles takes place from end to end of the complete rake.

**5.5. Lashing/securing:** All automobile car wheels must be secure with lashing arrangement provided by wagon owner/automobile Transporters Company with floor of the wagon.

**6. Marshalling:**

These wagons are specialised for transportation of automobiles cars only. This special wagon, both in empty and loaded condition should always be run as a special train. The wagon shall be moved only in a special train formation both in empty and loaded condition hauled by a single loco only, under approved special instructions to framed by the Chief operations Manager of the concerned Railways, RDSO speed certificate, CRS sanctions and various instructions/orders/circulars issued by the Railway Board from time to time.

**7. List of construction drawings: 7.1.****Structures:**

<b>DRAWING NO.</b>	<b>DESCRIPTIONS</b>
WD-11013-S-00	INDEX.
WD-11013-S-01	DIAGRAM.
WD-11013-S-02	GENERAL ARRANGEMENT (WAGON-A&B).
WD-11013-S-03	LOWER DECK FRAME ARRANGEMENT.(WAGON-A)
WD-11013-S-04	LOWER DECK FRAME ARRANGEMENT.(WAGON-B)
WD-11013-S-05	UPPER DECK ARRANGEMENT & DETAILS (WAGON-A&B)
WD-11013-S-06	LOWER DECK FRAME DETAILS (SHEET-I) (WAGON-A&B)
WD-11013-S-07	LOWER DECK FRAME DETAILS (SHEET-II) (WAGON-A&B)
WD-11013-S-08	LOWER DECK FRAME DETAILS (SHEET-III) (WAGON-A&B)
WD-11013-S-09	FLOOR PLATE ARRGT. & DETAILS OF LOWER DECK (WAGON-A&B)
WD-11013-S-10	BODY SIDE ARRANGEMENT & DETAILS (WAGON-A)
WD-11013-S-11	BODY SIDE ARRANGEMENT & DETAILS (WAGON-B)
WD-11013-S-12	END FLAP ARRANGEMENT & DETAILS (WAGON-A&B)
WD-11013-S-13	ROOF ARRANGEMENT & DETAILS (WAGON-A&B)
WD-11013-S-14	LIFTING ARRANGEMENT & DETAILS OF UPPER DECK (WAGON-A&B)
WD-11013-S-15	END SWING DOOR ARRANGEMENT (WAGON-A&B)
WD-11013-S-16	END SWING DOOR DETAILS (WAGON-A&B)
WD-11013-S-17	BRAKE GEAR ARRANGEMENT (WAGON-A&B)
WD-11013-S-18	BRAKE GEAR DETAILS
WD-11013-S-19	FITMENT OF AIR BRAKE EQUIPMENT AND PIPE LAYOUT (WAGON-A)
WD-11013-S-20	FITMENT OF AIR BRAKE EQUIPMENT AND PIPE LAYOUT (WAGON-B)
WD-11013-S-21	DETAILS OF PIPES FOR FITMENT OF AIR BRAKE EQUIPMENT
WD-11013-S-22	DETAILS OF FITMENT OF AIR BRAKE EQUIPMENT
WD-11013-S-23	BRAKE DIAGRAM
WD-11013-S-24	UNCOUPLING GEAR ARRANGEMENT & DETAILS
WD-11013-S-25	CENTRE PIVOT & SIDE BEARER ARRANGEMENT (WAGON-A&B)
WD-11013-S-26	MARKING DIAGRAM
WD-97025--S-35	ARRANGEMENT OF HIGH TENSILE CENTRE BUFFER COUPLER (NON-TRANSITION)

**7.2. Bogie:**

<b>DRAWING NO.</b>	<b>DESCRIPTIONS</b>
CONTR-9404-S/1	INDEX
CONTR-9404-S/2	BOGIE GENERAL ARRANGEMENT
CONTR-9404-S/3	CAST STEEL SIDEFAME
CONTR-9404-S/4	BOGIE DETAILS
CONTR-9404-S/5	CAST STEEL BOLSTER
CONTR-9404-S/6	WEDGE
CONTR-9404-S/7	SPRING DETAILS
CONTR-9404-S/9	BOGIE BRAKE GEAR ARRANGEMENT
CONTR-9404-S/10	BOGIE BRAKE GEAR DETAILS
CONTR-9404-S/11	L-TYPE COMPOSITION BRAKE BLOCK
CONTR-9404-S/12	WHEEL AND AXLE ASSEMBLY
CONTR-9404-S/13	WHEEL
CONTR-9404-S/14	LEADING DIMENSIONS & TOLERANCES
CONTR-9404-S/15	SPRING LOADED SIDE BEARER ASSEMBLY & DETAILS
CONTR-9404-S/16	MARKING SCHEME FOR CAST STEEL SIDEFAMES AND BOLSTER
CONTR-9404-S/17	BRAKE BEAM

**8. List of components used in BCACBM wagon, not generally used in other wagons:**

- 8.1. Belt Lashing/Car securement system-** These shall be provided by wagon owners/AFTO.
- 8.2. Ratchet wrench/Battery operated slow speed wrenches-** This shall be provided by wagon manufacturer/owners/AFTO.
- 8.3. Rollers for middle deck movement-** As per item no.-7 and 8 of RDSO drawing no WD-11013-S-05.
- 8.4. Screw jack Assembly-** As per item no.-7 of RDSO drawing no WD-11013-S-14.

**9. Proforma for SWTR:****PROFORMA FOR SINGLE WAGON TEST FOR BCACBM WAGON**

Wagon No. .... Bogie Make..... DV.NO &amp; MAKE.....

S.No.	Check	Specified Value	Observed Value
1.	Pressure in BP	$5 \pm 0.1 \text{ kg/cm}^2$	
2.	Pressure in AR	$5 \pm 0.1 \text{ kg/cm}^2$	
3.	Leakage from the system in one minute.	$0.1 \text{ kg/cm}^2$ (max.)	
4.	Full service application:		
4.1	Brake cylinder filling time (Pressure rise from 0 to $3.6 \text{ kg/cm}^2$ )	18 to 30 sec	
4.2	Maximum brake cylinder pressure)	$3.8 \pm 0.1 \text{ kg/cm}^2$	
4.3	Reduction in BP pressure required for full service application	$1.3$ to $1.6 \text{ kg/cm}^2$	
5.	Release after full service application:		
5.1	Draining time (Brake cylinder pressure to fall from $3.8 \pm 0.1 \text{ kg/cm}^2$ to $0.4 \text{ kg/cm}^2$ )	45 to 60 sec	
6.	Sensitivity of brakes. Isolate brake pipe from main line. Check the response of brakes when brake pipe pressure is reduced at the most equal to $0.6 \text{ kg/cm}^2$ in 6 seconds.	Brake should apply within 6 sec	
7.	Insensitivity of brakes. Isolate brake pipe from main line. Check the response of brakes when brake pipe pressure is reduced at least equal to $0.3 \text{ kg/cm}^2$ in 60 seconds	Brake should not apply.	
8.	Emergency application:		
8.1	Brake cylinder filling time (Pressure rise from 0 to $3.6 \text{ kg/cm}^2$ )	18 to 30 sec	
8.2	Maximum brake cylinder pressure)	$3.8 \pm 0.1 \text{ kg/cm}^2$	
9.	Piston stroke	$100 \pm 10 \text{ mm}$	
10.	Leakage from brake cylinder after emergency application	$0.1 \text{ Kg/cm}^2$ (max.) within 5 minute	
11.	Automatic exhausting of brake cylinder and control chamber.		
11.1	Apply emergency brake (i.e. $\text{BP}=0 \text{ kg/cm}^2$ ) check the brake cylinder pressure after giving a brief pull to release book.	Brake Cylinder and Control Reservoir should exhaust automatically.	
12.	AR Charging Time (pressure rise from 0 to $5 \text{ kg/cm}^2$ )	$175 \pm 30 \text{ Sec.}$ for C3W D.V $60$ to $120 \text{ Sec.}$ for KEO D.V	
13.	CR Charging Time (pressure rise from 0 to $4.8 \text{ kg/cm}^2$ )	$165 \pm 20 \text{ Sec.}$ for C3W D.V $160$ to $210 \text{ Sec.}$ for KEO D.V	

S.No. 12 to 13 to be checked at the time of prototype wagon only.

Date:

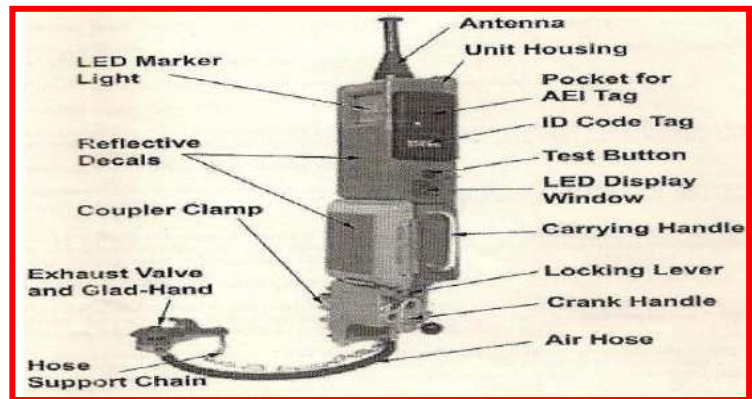
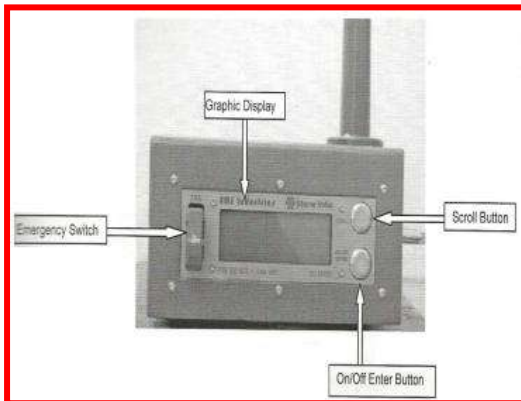
Signature and name of  
Testing Authority

## Proposed Electronics Equipments for Freight Stock

## APPENDIX- X

Following electronics equipments has been proposed by RDSO for better utilization and safety of freight stock.

### 1. EOTT ( END OF TRAIN TELEMETRY)



CDU( Communication display Unit)

SBU( Sense and Braking Unit)

The EOTT system is alternative of Guard and Brake van .EOTT is a system by which it is possible to monitor brake pipe pressure in the last vehicle of train in the locomotive cab. It also helps the driver to apply brake simultaneously from rear of the train. EOTT system consist of two units , CDU( communication display Unit) and SBU( Sense and Braking Unit) .CDU is fitted in Driver cabin and SBU is fitted on rear coupler of last vehicle. SBU is connected to the last vehicle BP hose Pipe. CDU connects to SBU through Radio Frequency communication. SBU sends Radio signals at regular intervals and CDU displays BP pressure of last vehicle & other related data. Operation frequency range is 406.5 MHZ.

Various functions of EOTT:

- ▶ Distance measurements in reference to locomotive.
- ▶ Last vehicle BP pressure monitoring.
- ▶ Last vehicle low pressure alarm.
- ▶ Motion status (Moving or stopped)
- ▶ Marker light status at last vehicle (ON/OFF).
- ▶ Battery status.
- ▶ Loss of communication alarm.
- ▶ Automatic and manual communication test.
- ▶ Train Emergency application/ Service application braking from rear.
- ▶ Data logging facilities.

## 2. EIMWB( Electronic In Motion Weighbridge)

EIMWB installed on Indian Railways, measures gross weight of freight stock during in motion with maximum speed up to 15 kmph. The primary purpose of weighbridge is to check overloading in wagons which damages the track and rolling stock. Electronic in motion Weigh Bridge consist of

- (i) Weigh rails of length 5.5 m.
- (ii) Track switches/sensors for speed and wagon type detection.
- (iii) Control console with electronic cards for implementing track switch logic and receiving signals from weigh sensors for further processing.
- (iv) A personal computer, a key board & a printer computer directly linked to control console, for operation, viewing and printing output.

EIMWB can measure wagon of maximum weight up to 120 T with minimum scale interval of 100 kg. Weighment on EIMWB is governed by Metrological Laws -OIML R -106 and Standards of Weights and measures Rules, 1987.RDSO specification WD-29-Misc-05 lays down the broad technical requirements of Electronic In Motion Weigh Bridges used on IR.



## 3. Guard Comfort kit (Solar PV module with fittings)

Guard Van are used mostly as last vehicles in freight trains & are manned by train guard. Owing to guard vans being part of freight trains, they generally lie unattended in freight maintenance lines/yard/sick lines/workshops. Currently the guard vans do not carry any power generating source and hence no power consuming fittings (light/fan) are fitted inside the guard vans.

RDSO has developed functional requirements for Guard Comfort kit (Solar PV module with fittings) to be installed in Brake Vans. The end purpose is to



provide Light, Fan, Mobile Charging Facility inside Guard Van using roof mounted, pilferage proof Solar PV Module along with its associated equipment (Batteries, Light, Fan, Switch, Socket, any other) and necessary connection. The following functional requirements have been prescribed:

<b>SN</b>	<b>Equipment</b>	<b>Technical Requirement</b>
1	Light fitting Table Mounted (Two fittings) AND Roof Mounted (One Fittings)	<ul style="list-style-type: none"> <li>• LED Light (for low power consumption)</li> <li>• 10W (Min) for Table Mounted &amp; 15 W(Min) for Roof Mounted</li> </ul>
2	Fan Fitting: Wall Mounted (Two Numbers)	<ul style="list-style-type: none"> <li>• 8” (Min) Fans, Wall Mounted with manual/auto swivel arrangement</li> <li>• Power consumption 30 W (max)</li> <li>• Self-contained Unit with anti-pilferage arrangement, connectors &amp; other required essentials.</li> </ul>
3	Switch board with Mobile charging point (Two numbers, Wall Mounted)	<ul style="list-style-type: none"> <li>• USB port for mobile charging</li> <li>• Switch board to incorporate switches needed for Light &amp; Fans</li> </ul>
4	Solar PV Module with all Associated accessories/ equipment/ connections/ wiring	<ul style="list-style-type: none"> <li>• Solar PV module of sufficient capacity to operate the above tabulated electrical loads for continuous operations for min 12 hours, needs to be provided</li> <li>• The Solar PV module along with accessories such as battery, inverter (if needed), connectors, junction boxes, switch gears etc should be a self-contained modular unit that can be fitted in either of the locations detailed in 3.2 below.</li> <li>• The Solar PV module and associated accessories should be provided with suitable anti-pilferage devices to prevent chances of theft/damage/loss.</li> </ul>

#### **4. RFID Tags on Wagons ( Radio Frequency Identification Tags)**

The purpose of providing RFID tags on freight stock is to result in Automatic Wagon Identification using Radio Frequency Identification.



RFID tag position on wagon



**RFID tag Reader**

Indian Railways has mandated provision of RFID tags on to the wagons being produced w.e.f 2016. It will enable automatic determination of wagon consist and therefore no manual number taking. It will enable automatic identification of wagons for in motion weighbridge and wayside diagnostic systems. Its implementation will lead to a progressive shift from periodic maintenance to predictive maintenance of rolling stock by leveraging Information Technology.

# **Appendix-XI**

## **Duty Lists of C&W Supervisors (Freight)**

# INDEX

S.N.	Description	Page No.
<b>A</b>	<b>Divisional HQ</b>	--
1	SSE C&W(Divisional HQ)	3
2	SSE (Training & Computer)	4
3	Statistical Inspector	4
4	SSE/ (Material Control)	6
5	SSE C&W (Planning)	7
6	SLI/Div.HQ	8
7	Important Guidelines for Loco Inspectors/Fuel Inspectors working under (C&W) Depots for management of Fuelling Installations.	10
<b>B</b>	<b>Yard Examination</b>	
8	SSE/G(C&W)/Yard	12
9	SSE (C&W) Yard/ Incharge	14
10	SSE (C&W) Yard/ Shift Incharge	16
11	JE/SSE(C&W)/ Train Examination Yard	17
12	Duties of C&W Inspectors (CWI)	19
13	SSE/C&W (Sick Line)	23
<b>C</b>	<b>ROH Depot</b>	
14	SSE/C&W)/ROH/Incharge	24
15	(SSE/C&W)/ROH/Field	25
16	SSE(C&W)/Store/ROH	26
17	SSE (M&P)/ROH	27
18	SSE (C&W)/Air Brake	28
19	SSE (C&W)/Bogie	29
20	SSE (ART/ARME)	30
21	SSE/ SPART	31

## **Duty Lists of C&W Supervisors in Div. HQ.**

### **1. SSE C&W(Divisional HQ)**

*He is responsible for the following duties assigned to him :-*

- 1) Punctuality -**  
Direct punctuality loss cases, Indirect punctuality loss cases, train partings and unusuals, identification of the bad runners on the basis of above failures.
- 2) Statistics -**  
Major statistics on C&W, action plan targets.
- 3) Technical Meetings -**  
Organization of monthly technical meetings of C&W supervisors with Sr.DME.
- 4) Technical standing orders -**  
HQ's technical standing orders implementation and help in issuing local technical standing orders on C&W and trouble shooting.
- 5) Derailments/Accidents -**  
Providing assistance in accident/derailment inquiries and technical notes.
- 6) PCDO's /MCDO's-**  
Timely submission of monthly C&W PCDO and MCDO to HQ and to DRM and the action plan targets.
- 7) HOD meetings -**  
Providing the statistics for the HOD meetings and Conferences.
- 8) ISO Certification -**  
preparation of ISO documents and related manuals, correspondence of letters/Instructions to depot incharges, preparation of handouts during quality audits and inspections by HQ officers, record keeping and watch over the implementation of ISO instructions to the grass root level and timely analysis of the maintenance activities on ISO certified depots.
- 9) Management and up keeping of the computer hard and soft wares,** new development of the programmes, generation of data base reports, Brochure making etc.
- 10) Training Activities-**  
Management of BTC, Training modules and training material to staff and supervisors, syllabus for the different courses undergone in the BTC, Technical hand outs for the staff.
- 11) Field inspections** as per the allotted quota.
- 12)** Any other work given time to time by the Mechanical Officers.

## **2. SSE (Training & Computer)**

*He is responsible for the following duties assigned to him –*

- 1) **Condemnation of rolling stock and its proper accountal-**  
The timely submission of the condition report, chasing of the BUO's of the condition reports submitted, submission of the DS-8 and up to the final disposal of the Rolling stock.
- 2) **Management and up keeping of the computer hard and soft wares,** new development of the programmes, generation of data base reports, Brochure making etc.
- 3) **Training Activities-**  
Management of BTC, Training modules and training material to staff and supervisors, syllabus for the different courses undergone in the BTC, Technical hand outs for the staff.
- 4) **HOD's inspections-** Compliance over the HOD's inspection items, it's replies to HQ and the concerns.
- 5) **Field inspections** as per the allotted quota.
- 6) Any other work given time to time by Mechanical Officers.

## **3. Statistical Inspector**

*He is responsible for the following duties assigned to him :-*

### **Divisional statistical section:**

He will monitor Locomotive performance data given as under:

1. Railway wise, Shed wise engine usasge: Goods service, territorial basis, based on daily engine wise/section wise working of trains.
2. Monthly engine disposition statement based on engine wise daily: hourly outage, railway wise/shed wise/service wise
3. Section wise no. of goods train run, loaded wagons kms, empty wagon kms, FTKM, Wagon tare tonne kms, brake van kms, brake van TT kms.

4. Railway wise/shedwise engine kms, Train hours and Engine hours on mail express and passenger services.
5. No. of mail /express/Passenger train running- sectionwise/railway wise/shedwise
6. Summary of military special, train run on division  
Base/shed wise - Railwaywise/section wise  
No. of military special train , Vehicle kms, NTKM, Vehicles TT kms etc.
7. Summary of other coaching trains:  
Engine wise/sectionwise/base wise /shedwise/Railwaywise, with loaded/Empty wagons/ Vehicles and Tonnage.
8. Summary of engineering department trains - Ballast Train/ Material Trains  
Nos. of trains, wagon kms, FT kms, Wagon TT kms - sectionwise/railwaywise.
9. Monthly evaluation report - Advance information of train KMs and NTKMs, engine hours etc.
10. Calculation of usage of AC & DSL traction
11. Record of GTKM of AC & DSL locomotives.
12. Other statistical parameters and statements, required by HQ office time to time.
13. Any other work given time to time by Mechanical Officers.

#### **4. SSE (Material Control)**

*He is responsible for the following duties assigned to him –*

1) **Management of C&W material cell -**

Timely submission of the demand notes, procurement of the non-stock and the stock items, arrangement of the transportation for bringing the material to the stores, monthly visit to the C&W depots for identification of the surplus items and the critical items, their transaction to the depots where these items are required, material review, HQ's store meeting and timely submission of the material PCDO to HQ.

2) **Management in failure investigation of the C&W failed components -**

Ensuring quick submission of the failed components of coaching stock to concerned workshop and goods stock to C&M's testing at wagon workshop, chasing for their reports and it's documentation.

3) **Establishment -**

C&W staff matters, establishment and the staff reviews.

4) **Budget -**

Inventory control, keeping watch on proper booking of the expenditure to the proper heads.

5) **Field inspections** as per allotted quota.

6) Any other work given time to time by Mechanical Officers.



## 5. SSE /C&W (Planning)

*He is responsible for the following duties assigned to him :-*

- 1) **Initiation of Tenders and contracts** and monitoring of execution of the same.
- 2) **Preparation of Terms and Conditions** of tenders/contracts as well as estimates and close watch over performance of tenderers/ contractors.
- 3) **M&P Programme -**  
Preparation of M&P programme and chasing of sanctioned items, preparation of specifications and estimates for sanctioned items, commissioning of items and completion reports.
- 4) **Works Programme -**  
Preparation of preliminary works programme and petty works programme and chasing of sanctioned works, preparation of necessary drawing/Layouts for works, specifications and estimates for sanctioned works/items and completion reports of works.
- 5) **Rolling Stock Programme -**  
Preparation of Rolling Stock programme and chasing of sanctioned RSP, preparation of necessary drawings/Layouts/specifications and estimates for sanctioned RSP, commissioning of RSP and completion reports.
- 6) **Field inspections** as per the allotted quota.
- 7) **Management of ARTs and ARMEs -**  
Deployment of staff in the ARTs and ARMEs, timely inspections by the officers and supervisors, problems of ART/ARME related items, preparation during inspection of HQ/Div. Officers.
- 8) **Availability of items as per Standard Lists -**  
Ensuring availability of tools and equipments in all ARTs and ARMEs as per standard lists, planning and replacement of over due POH rolling stock.
- 9) **Compliance of HLC recommendations -**  
procurement and availability status of HLC recommended items. Attending disaster related meetings at Division as well as HQ level.
- 10) **Complete procurement of ART/ARME items & chasing -**  
Procurement of ART/ARME/SPART items at DMM level as well as COS level, chasing of COS case files and Purchase orders once in a fortnight.
- 11) **Correspondence and timely submission of statements -**  
replies to HQ letters, correspondence for budgetary offers with private firms, preparation of statements by OS-I and its checking, timely submission of statements and reply to HQ office.
- 12) Raising of warranty claims of all failed materials within warranty period.
- 13) Any other work given time to time by the Mechanical Officers.

## 6. SLI/Div.HQ

***He is responsible for the following duties assigned to him :-***

### **1) Crew Management -**

Monitoring of refresher and PME due running staff, smooth and efficient functioning of Drivers lobby, Monitoring of predeparture detention of trains at Depots, control over out station rest of running staff, record of timely monitoring and counseling of Drivers, Shunters and Asstt. Drivers by Loco inspectors, Availability of items of personnel store for Drivers and uniforms and control over overtime and correspondence of running staff related items to HQ office.

### **2) Running Room Management -**

Following areas to be managed to ensure general upkeep and smooth functioning of Running Rooms –

***MAINTENANCE:*** Repairs to roofs, doors, windows, toilets and bathrooms wherever necessary, Provision of adequate water supply and provision of showers in bathroom, Regular white washing of buildings, Provision and repairs of drains and regular cleaning of drains, Provision of adequate lights and fans and repairs thereof, Provision of adequate beds and furniture and repairs thereof, Modernization of kitchen and lavatory, Regular cleaning by sweepers.

***BEDS AND LINENS:*** Provision of rubberised coir mattress and pillows, Provision of nylon mosquito nets, Provision of adequate Linens and washing thereof and its proper accountal.

***FACILITIES AND AMENITIES:*** Provision of cooler for drinking water, Provision of desert cooler, Provision of exhaust fans in kitchen, Provision of cooking gas, Provision of newspaper and magazines, Provision of good quality utensils.

***MISCELLANEOUS:*** Provision of dustbin near kitchen and provision of litter bins in rooms, Provision of curtains and doormats, maintenance of gardens, Tree plantation during rainy season, Beautification with plants in pots (leaf variety).

***CLEANLINESS AND GENERAL UPKEEP:*** Cleanliness in the running room premises as well as in the kitchen and rooms, Twice cleaning of rooms in one shift by wet cloth of phynaal, Application of pest control in the rooms & kitchens, Uniform and behavior of cooks, bearers & caretaker, Record keeping and accountal in the running room stores in presence of loco foreman, Functioning of Water cooler and aqua-guard, Provision and maintenance of Meditation room, Cleanliness of toilets and bathrooms.

### **3) RCD Management**

Performance of Flow meter, Electric fuel pump and Diesel Pumps, Availability of fire extinguishers, sand and water buckets, Changing of filter of filter housing, Condition of decanting pipe and fuelling pipes, Disposal of spilled HSD oil etc.

#### ***Accountal of HSD oil -***

HSD oil ledger at HSD oil depot, HSD oil issues for non-traction purposes, Taking over/Handing over of HSD oil after each shift, HSD oil issues to locomotive, Discrepancy of fuel/Lube oil while taking over/handing over by drivers, HSD oil issue - Posting in Trip Cards, Monitoring of Trip ration, Effectiveness of Water finding and oil finding pastes, Shortage in fuel and write off action, Reporting of Daily position of HSD oil by HSD oil depot to HQ, Receipts of the HSD oil, Filling and sending of G-210 F statement to HQ,

Placement of tank wagons, detentions and decanting, Testing of samples, Sludge disposal and accountal thereof.

***Supervision and General upkeep -***

Provision of sketch of HSD oil installation, Inspection of Storage tanks and equipments by SLI of depot once a week, Calibration Charts, Calibration of Storage tanks, Provision of Boards/Bar charts indicating parameters/equipments available.

***Verification of Stock -***

Verification by Accounts stock verifier - once a year, Verification by SSE - once a month, Verification by SFI/SLI - Feb, June, Oct. every year, Verification by Sr DME/DME/ADME - April, August, December every year.

***Precautions at HSD oil Installation -***

Premises in and around all the installations should be free from inflammable materials, Fire extinguishers and buckets should be maintained in effective condition, Only fire proof lighting equipments should be used, HSD oil in barrels, Plants should not be allowed to be grown within the boundary walls, Timely preparation and dispatch of periodic statements, Performance of Oil Company and maintenance by them, Staff deployment and their grievances, Pending Claim cases and review thereof - action taken by SFI, Steps being taken for control over SFC, Availability of Standard equipments at HSD oil installation, Computerization of Fuel management and Accounting system, Condition of Fuelling and Decanting pipe lines and Valves, Cleanliness of Installation and Modifications and Innovations at Installation.

**4) Technical standing orders -**

HQ's technical standing orders pertaining to running staff and RCDs, implementation and help in issuing local technical standing orders on loco and trouble shooting.

**5) Drivers Lobby -**

Following areas will be managed to ensure general upkeep and smooth functioning of Drivers Lobby -

Ensure functioning of CMS, Breath Analyzer Machines etc. Enusre availability of Crew On & Off duty Register, Signal and Track defective Register, Driver's Instruction book, Caution Order files, Illuminated Speed Restriction Board, Staff authorized to wear spectacles, Learning Road Register, Due medical test list of staff, Booking Books, Safety Posters and Slogans, First Aid Box, Stretchers, Other records at Crew booking lobby, Checking of important registers, files and Circulars once a month, provision of furniture for lobby and drinking water.

**6) PCDO activities related to running staff -**

Timely submission of monthly running staff PCDO and MCDO to HQ and to DRM and the action plan targets.

**7) HOD meetings -**

Providing the statistics for the HOD meetings and Conferences pertaining to Running staff and RCDs.

**8) Field inspections as per the allotted quota.**

**9) Any other work given time to time by the Mechanical Officers.**

## **7. Important Guidelines for Loco Inspectors/Fuel Inspectors working under (C&W) Depots for management of Fuelling Installations.**

- 1) The Fuel inspector should go through the Oil consumption prior to issue of HSD Oil at the fuelling point and cross check with the latest trip ration taking into account in case of any excess consumption, the fuel inspector will carryout the necessary investigations.
- 2) Fuel inspector and inspector of Stores account will make a percentage check of T-41B with entries in the trip card to ensure that issue on T-41B have been actually entered on the trip card.
- 3) TVA factor of 0.0009 litre per degree centigrade variation on the total HSD Oil quantity received should be worked out as and when required.
- 4) Dip reading into the oil tanks should be taken only when oil level in the tanks have stabilized, it should be ensured that the dead weight of the tape has touched & is resting at the bottom & that the tape does not appear to be bent/curved to ensure correct oil level readings.
- 5) Water finding paste and oil finding paste to be used before taking Dip reading into the Road tanks and storage tanks.
- 6) Before commencing the decanting process, it must be ensured that there is adequate room in the storage tank into which decanting is to be done to avoid overflow of oil.
- 7) Tank wagons/Lorries will be decanted between sunrise and sunset as laid down in the Petroleum Act.
- 8) Tank Lorries should be completely decanted before giving clearance for the tank lorries to move out of the HSD Oil installation, all delivery valves of tank lorries may be kept open when the lorries leave shed.
- 9) Delivery of Tank lorries should not be accepted if the challan quantity and the actual quantity in the lorry differs. CHALLANS SHOULD NOT BE SIGNED TILL CHECKS ARE CARRIED OUT IN ALL RESPECTS.
- 10) The dip measurement of tank lorries in each compartment should be taken personally before and after complete decanting.
- 11) Tank lorries are to be placed on level ground platform and some time to be allowed for the product level to settle down.
- 12) All tank wagons/lorries received in the HSD Oil Installation should appear in the register whether shortages were noticed or not in the HSD prescribed format.
- 13) To ensure proper upkeep of the installation and to ensure that no unwanted things are kept in the vicinity, each installation is allotted to an

- Inspector/Loco foremen who will be over all incharge of the staff and installation.
- 14) A certificate of correctness of flow meters should be obtained from the inspector of weight and measures every year without fail.
  - 15) The incharge of the HSD Oil installation should maintain a record of issues to locomotives in the format (HSD 22).
  - 16) HSD Oil should not be issued for any purpose other than the use (Running and maintenance) except for the following as permitted by Railway Board & specific sanction obtained from GM(O)/DRM.
    - a) Self propelled Ultrasonic Rail testing cars.
    - b) Diesel break down Cranes.
    - c) Oscillograph/Dynamo meter cars.
  - 17) While fuelling locos, great care should be exercised so that the locomotive tank does not overflow. Issues of HSD Oil for use of locomotives should be against T-41B which must be signed by the incoming driver.
  - 18) The installation should not be used as a store for stationery, filters, Lube oil or HSD oil in barrels.
  - 19) Surprise checks on fuel installation periodically and checks to be carried out on wastage, spillage, misuse or pilferage of HSD oil.
  - 20) Keep an eye on the work of the fuel statistical and accounting staff to ensure that accounts are correctly maintained and returns are submitted on due dates.
  - 21) Carryout surprise check on the incoming and outgoing balance in loco tanks with the respective fuel vouchers.
  - 22) Ensure that proper samples are drawn for laboratory tests as per the procedure laid down.
  - 23) Watch the performance of locomotives and crew in comparison with the trip ration fixed & take corrective action by duly analyzing the cause for excess consumption.
  - 24) Control over lubricating oil consumption and the consumption is closely watched and the locos heavy on lube oil consumption are monitored and defects rectified.
  - 25) Periodically check the accuracy of flow meters, calibration of storage tanks and fuel oil tanks/Glow rods of locomotives.

## **Duties of C&W Supervisors working in Freight Depots.**

### **8. SSE/G(C&W)/Yard:**

*He is responsible for the following duties assigned to him –*

#### **A. GENERAL:**

1. Overall in-charge of the unit and responsible for all matters and co-ordination of all activities viz., technical, establishment, operational and stores, etc.
2. Staff deployment at primary locations like Yard, M&P section, ROH & Sick Line section, Bogie section, Rolling Stock section, Store and Establishment section, IOC/BPCL Gantries etc.
3. Co-ordinate meeting of section incharges with Mechanical officer of Depot for Monthly Target & other issues.
4. Maintenance of all CC rakes & their monitoring.
5. Maintenance of depot premises including contracts & tenders.
6. Keep close watch on consumption pattern of all store items and their timely procurement process. Management and record keeping of different type of imprests.
7. Keep close co-ordination between all section incharges/ Shift incharges for better maintenance.
8. Ensure proper implementation of QMS & record keeping as per ISO requirement including depot PCDO.
9. Attention to all unfit wagons at Road side stations including examination of departmental train whenever required.
10. Control over data feeding of wagons with the liaison of C&W controller and communication with SSE (Div./HQ).
11. Circulation and implementation of HQ's/Board's/Divisional instructions to the related sections.
12. Administrative control of staff working in different sections including DAR, Leave, CRs, staff training, refresher etc. Payment and wages of staff, Passes/PTO's & quarter allotment issues for staff working under him shall be looked after.
13. He shall be responsible for maintaining dead stock register in his territory and verification thereof time to time.
14. He shall be responsible for timely initiation of M&P and Works proposals and chasing of sanctioned items in liaison with SSE (Planning).

15. He shall be responsible for budgeting and expenditure control on staff as well as stores.
16. Ensure timely refresher training of staff & field training to newly inducted staff in yards.
17. Ensure lighting arrangement in yards & ROH depot i.e. tower lighting and pathway lighting as per recommendations.
18. Ensure safety of staff working in Depot.
19. Ensure proper documentation of record of all activities i.e. time of placement of rake & release time of rake at Yard & placement/drawn out of wagons at ROH depot.
20. Maintaning a close co-ordination with Neutral Organization (NTXR) for outturn of Depot. Also co-ordination with sister departments e.g. Electrical maintenance, Operating, Store etc.
21. Maintaning a cordial & harmonious relation with Union office bearers and solving their grievances.
22. Responsible for staff welfare and amenities.
23. Responsible for monitoring and control of PDD of freight trains
24. Any other work given time to time by the Mechanical Officers.

**B. ISO Wing:**

1. Ensure proper record keeping at every working point as per ISO requirement.
2. Analysis of Broken components from various agencies & implementation of reports.
3. Other ISO related documentation and visit of representatives.
4. Inspections as per Railway Board's letter No. 99/AM(M)/Inspections dated 16.08.1999.
5. Computerization and ISO system related work in his field of activity if assigned.

**C. Freight Depot Emergency Store:**

1. Ensure availability of material in Freight depot in liaison with SSE (Store).
2. Ensure timely Upkeep of Ledgers and house keeping of sub stores.
3. Ensure proper & timely collection of material from stores.
4. Ensure Preparation of specifications for procurement of non stock items.
5. Control over MUF and AAC of all stock items pertaining to Freight depot.
6. Ensure material assistance to all supervisors of freight depot.

## **9. SSE(Incharge)/ (C&W)/Yard:**

***He is responsible for the following duties assigned to him –***

1. Overall incharge of Freight Yard & ROH Depot for maintenance of freight.
2. Responsible for organizing Depot Technical meetings of C&W yard supervisors periodically and assessment of their quality of work done.
3. Keep co-ordination between shift incharges of train examination and Stores for better maintenance.
4. Control over data feeding of wagons with the liaison of C&W controller and communication with SSE (Div./HQ).
5. Responsible for keeping sufficient welding sets & related items like electrodes, cutting torches, welding holder, earthing cables & protective devices.
6. Responsible for efficient maintenance of rolling stock based at his depot / Station.
7. Responsible for timely maintenance of Rake test rigs with their peripherals and calibration of Gauges and valves.
8. Ensure proper documentation of record of all activities i.e. time of placement of rake, release time of rake etc.
9. Hold daily conference with C&W controller at 6 o'clock and arrange to communicate the daily statistics of the Depot as well as any unusual occurrence during 24 hrs.
10. Responsible for ensuring that incoming and outgoing trains are examined by the Train Examining staff in an efficient and systematic manner and repair executed expeditiously within the time allowed unless otherwise special reasons to do so.
11. Responsible for educating staff under his control about the rules/regulations and better maintenance practices pertaining to their duties.
12. Responsible for ensuring that the staff is safety- conscious and each member his jurisdiction executes his duties keeping safety rules in mind.
13. Responsible to ensure that each staff is well disciplined and exhausting his duties effectively and appearing in uniform at work places.
14. Responsible to see that duty rosters are exhibited for each and every category of staff at his Depot.
15. Responsible for ensuring availability of store items, tools and M&P's, proper accountal of consumption of items and also responsible for maintaining dead stock register and verification thereof time to time.
16. Responsible for checking of tools of artisan staff are correct, adequate in quantity and in good working order.



17. Carry out surprise inspections/ super checks of examined trains after certified fit by the concerned TXR and carry out night inspections periodically without fail.
18. Maintenance of Depot premises and implementation and execution of contracts pertaining to freight stock yard.
19. Carry out joint investigation on the spot into the cases of loss of punctuality, detention to the trains, etc. with TI/SM/LI/LF, PWI etc.
20. Ensure quick releasing of the rakes held up on the line within his jurisdiction.
21. Responsible for proper reclamation of components/items in the depots if required.
22. Responsible for timely disposal of defective and scrap materials from the yard.
23. Responsible for proper submission of periodical statements, examination figure MCDO of Yard statistics etc., and to reply to letters received from Divisional office and other correspondences and for maintaining the prescribed registers
24. Responsible for all rules as contained in the IRCA Rule Book and circulation and implementation of Board's / HQ/ Divisional general instructions for train examiners and staff.
25. Responsible for follow up the instructions of Sr DME/DME/ Sr SE(Gen) strictly and acting promptly.
26. Responsible for compliance of all inspection notes and timely implementation of better maintenance practices.
27. Responsible for maintaining Depot Performance Parameter Hand Out for keeping record of activities at a glance.
28. Any other work given time to time by Mechanical officers.

## **10. SSE (C&W) Yard/ Shift Incharge**

**He is responsible for the following duties assigned to him: -**

1. General Up keep and maintenance of Yard.
2. Liaison with other departments i.e. Operating/Area Control/ Section Control /Engg. staff etc.
3. Rolling in and Rolling out examination of freight trains coming for examinations.
4. Examination of attaching wagons,continuity of freight train & Issue of BPC.
5. Responsible for minimizing detention Hrs. of stocks in yard.
6. Responsible to ensue the quality of examination and repair of the examined train by supervisors as per laid down procedures / instructions.
7. Surprise inspection and checks on ready wagons and testing etc.
8. Implementation of all modifications issued by RDSO/Railway Board time to time.
9. Responsible for maintaining discipline in the functioning of Yard.
10. Responsible for maintaining records as per requirement of ISO.
11. Responsible for keeping vicinity clean, stacking of material, disposing of scrap and keeping record thereof properly.
12. Distribution of staff in case of unequal strength in examination gangs.
13. Work distribution of both gangs and decide priority of rakes.
14. Attendance of special gang, load yard staff and other staff working in their normal shift.
15. Super check at least one rake per day, CC rake to be given on priority. Report of the same to be submitted timely to the concerned officer.
16. Co-ordination between all gangs including load yard gang.
17. In case of no shift in charge is available, Senior most supervisors will take the above decision and pressure will be attended alternatively by examination supervisors.
18. Close monitoring of rake (type wise) examination time/detachment. If any rake has taken excessive examination time/ detachment, report to be submitted with proper justification to the concerned officer.
19. Ensure safety drive if any running is properly follow up the by the supervisor. Records to be checked & signed.
20. Ensure work attended on train by examination supervisor is correct. Check the concerned diary & signed.
21. Any other work given time to time by Mechanical Officers, SSE (Gen) & SSE/Yard.

## **11. JE/ SSE(C&W)/ Train Examination Yard.**

***He is responsible for the following duties assigned to him –***

1. Ensure proper entry of attendance & signature of staff concerned at appropriate place. It should be witnessed by supervisor at the bottom.
2. Supervisor should taken over the charges from the reliever & signed at appropriate place after entry as “CTO at 06:00 hrs/14:00 hrs/ 22:00hrs”.
3. Ensure availability of the minor lamps received in charge & maintain proper distribution of minor lamp in the respective diary in a proper way.
4. Ensure proper working of mobile work station & availability of materials on it.
5. Ensure proper & legible entry of wagon particulars & repair summary of the examined rake the by recorder. Also ensure signature of the recorder & finally supervisor should witness the record by signing on it.
6. Ensure signature of Tech./Supervisors on the registers/books maintaining at Coal Empty Yard like air brake testing, office order, SPA log book, hand brake split collar welding register, contractor’s safaiwala attendance etc.
7. Ensure all jacks (Screw + Hydraulic with accessories) in the office at time of charge made over to reliever.
8. Supervisors should ensure proper entry of the charges made over to the reliever & signed at appropriate place after entry as “CMO to reliever at 06:00 hrs/14:00 hrs/ 22:00hrs”.
9. Ensure proper keeping of train examination record in the concerned register of all type of rake i.e. CC rake , Premium Rake & End to end rake examination and issue of BPC.
10. Maintenance of wagons in the rake as per instructions given in maintenance manual
11. Maintenance of rake test rigs, air pressure pipe lines & reservoirs.
12. Maintenance of all innovation items being provided in CC rakes.
13. Ensure scrap collection and keeping up of premises clean.
14. Monitoring and implementation of C&W drives launched by mechanical officers time to time.
15. Under gear/upper gear examination and complete testing of Rake in yard.
16. Attention to over due ROH/POH wagons & sick marking of defective wagons.
17. Computerization and ISO system related work in his field of activity if assigned.
18. Ensure sick wagon % is maintained well within prescribed limit.
19. Ensure proper availability of lighting for train examination/rolling in and rolling out. Also timely removal of released brake blocks and other material form yard and keep pathways free of obstruction.

20. Ensure proper & standard tool kit for train examination staff.
21. Ensure Rolling in & Rolling out Examination of all Incoming & Out going Trains respectively
22. Any other work given time to time by Mechanical Officers, SSE (Gen) & SSE/Yard.

## **12. Duties of C&W Inspectors (CWI).**

*The duties of C&W inspectors are summarized as under:*

- i) Inspections*
- ii) Field work*
- iii) General work*

### **A- COACHING:**

#### **I. INSPECTIONS:**

1. Inspection of primary based rakes for monitoring of performance of rake/rakes with respect to equipment failure and quality of maintenance, including follow up of observations.
2. Surprise checks of staff working in passenger yard, with respect to rolling- in and rolling-out examinations, carriage watering and attention to public complaints by on duty supervisors and staff etc.
3. Surprise checks of rake maintenance activities, for staff attendance, quality of rake maintenance, brake power testing, working of ACP apparatus., testing of rakes on the RTR etc. and working knowledge of staff and supervisors.
4. Surprise night inspections as ordered by Mechanical Officers.
5. Inspections of documentation of rake maintenance activity and schedule of repairs.
6. Inspections of IOH sheds with respect to repairs carried out during IOH as per demand of maintenance supervisor, short coming to be highlighted to mechanical officers and follow up.
7. Foot plate inspections of mail express, passenger trains and goods trains for monitoring & counseling of drivers, Asst. drivers and guards with respect to trouble shooting on coaching and goods stock of Air brake rolling stock.

#### **II. FIELD WORK:**

1. Carry out drives on his Depot based coaching stocks as ordered time to time.
2. Carry out failure investigations with LI and TI whenever required.
3. Ensure non running of coaches over due for schedule maintenance & repairs.
4. Reporting of failures, repairs carried out on the coaches within 100 days of POH.
5. Ensure the modifications, which are advised to be carried out during primary maintenance, are being done correctly and timely.

6. Regular inspection at road side stations, counseling of operating staff with respect to C&W trouble shooting and shortage of C&W fittings provided at stations for emergency.

### **III GENERAL:**

1. Counseling of C&W staff and supervisors with respect to working knowledge and trouble shooting of vacuum and air brake stock both, as well as importance of Rolling-in and Rolling-out examinations of trains at STR points.
2. Counseling of operating (both loco and traffic) staff on the subject of trouble shooting of air brake rolling stock.
3. Attending technical meetings, seminars & workshops as arranged time to time actively for improvement of knowledge of other staff and conduct DAR enquiries.
4. Checking of calibration of USFD, Torque wrenches and gauges being used in the depots.
5. Check whether proper procedure is being followed for repairs of various assemblies of coaching & goods stock.
6. Checking of coaches, received in yard after POH and giving feed back to POH shop, if required.
7. Passing on the information to train examination staff regarding various DAI's and modifications, to check and report their limit of implementation.

### **B- GOODS:**

#### **I. INSPECTIONS:**

1. Inspection of goods trains examined in the yard for monitoring of performance of train with respect to equipment failure and quality of repairs/examination, including follow up of observations, checking of cutting tools and equipments of staff.
2. Surprise checks in goods yards with respect to prompt axle box feeling, Rolling-in & Rolling-out examinations, CC, Premium & End to End examinations and repairs by staff.
3. Surprise checks of flying gang staff, working at road side stations.
4. Surprise night inspections as ordered by Mechanical Officers.
5. Inspections of documentation of train examination activities in yards and repairs carried out.
6. Inspections of ROH sheds with respect to repairs carried out during ROH as per extent instructions laid down in the G-70 & G-95 technical pamphlets & G-106.

7. Foot plate inspections of mail/goods trains for monitoring of working knowledge of drivers, Asst. drivers and guards with respect to trouble shooting on coaching and goods stock of Air and Vacuum brake rolling stock.

## **II. FIELD WORK:**

1. Carry out drives on goods stocks as ordered time to time.
2. Carry out failure investigations with LI and TI correctly.
3. Reporting of failures, repairs carried out on the wagons within 100 days of POH.
4. Ensure the modifications which are advised to be carried out during sick line attention or during ROH, are being done correctly and timely.
5. Regular inspection at road side stations, counseling of operating staff with respect to C&W trouble shooting and shortage of C&W fittings provided at stations for emergency.
6. Analysis of unusual occurrences (Hot axle, Train Parting, Brake binding etc.) and will take suitable corrective actions.
7. Follow up of warranty claims of failed components within warranty period.

## **III. GENERAL:**

1. Counseling of C&W staff and supervisors with respect to working knowledge and trouble shooting of air brake stock as well as importance of rolling-in examination and box feeling.
2. Counseling of operating (both loco and traffic) staff on the subject of trouble shooting of air brake stock.
3. Attending technical meetings, seminars as arranged time to time for improvement of knowledge of other staff and conduct DAR enquiries.
4. Checking of calibration of USFD, torque wrenches and gauges being used in the wagon depots.
5. Check whether proper procedure is being followed for repairs of various assemblies & parts.
6. Checking of wagons, received in yard after POH and giving feed back to POH shop, if required.
7. Passing on the information to train examination staff regarding various WAI's and modifications, to check and report their limit of implementation.

**C. (Goods) Other duties:**

1. Responsible for roadside stations, maintenance of fire extinguishers, weighing machines, 8 Wheeler clamps in his jurisdiction.
2. Attending sick vehicles at Road side stations.
3. Attending goods unusuals i.e. train parting, H/P Disconnection at out station and depot whenever required.
4. Responsible for goods detention at depot.
5. Examination of tower wagons at nominated depots if assigned.
6. Inspection of ready rakes in freight yard.
7. Attending freight unusual in liaison with SSE (G) & C&W Controller.
8. Attending VIP movements & maintenance and placement of VIP Salloons / Special Trains in depot if assigned.
9. Computerization and ISO system related work in his field of activity if assigned.
10. Inspections as per Railway Board's letter No. 99/AM(M)/Inspections dated 16.08.1999.
11. Any other work given time to time by the Mechanical Officers.

---



### **13. SSE/C&W (Sick Line):**

***He is responsible for the following duties assigned to him –***

1. Proper record keeping & maintenance in wagon sick line.
2. Responsible for making Sick/unfit wagons fit at Depot as well as Road side stations.
3. Arranging clamps for Road side station if required.
4. Assistance in maintenance of ART & ARME if work assigned
5. Responsible for M&P maintenance and record keeping in sick line.
6. Responsible for upkeep in sick line and cleanliness in the premises.
7. Revalidation / Examination of material train and issuing of BPC.
8. Computerization and ISO system related work in his field of activity if assigned.
9. Keep sick wagon percentage well within prescribed target.
10. Analyse cases of repeated sick marking of wagons and take corrective actions.
11. Responsible for implementation of proper welding procedures in sick line.
12. Executing the contracts and preparation of bills related to assigned contracts.
13. Any other work given time to time by the Mechanical Officers.

## **Duties of C&W Supervisors working in ROH Depots.**

### **14. SSE/C&W)/ROH/Incharge:**

***He is responsible for the following duties assigned to him –***

1. Overall incharge of ROH of wagons in ROH Depot. Ensure proper maintenance and documentation of all relevant records of ROH.
2. Responsible for attending Break down duties and complete maintenance of break down rolling stock in depot.
3. Responsible to attend maintenance of Coaches/Wagons of ART/ ARME and timely testing thereof if assigned.
4. Responsible to attend restoration and investigation in case of accident in the Depot/Out station.
5. Responsible to implement laid down procedures as per latest wagon maintenance manual/ RDSO circulars/HQ directives in ROH work.
6. Responsible for proper reclamation of spares, matching and grouping of spares required in wagon maintenance.
7. Responsible for proper implementation of welding procedures.
8. Responsible for making analysis of failed components of wagons.
9. Responsible to calibrate the measuring gauges and timely correspondence thereof to divisional HQs.
10. Responsible for ensuring the availability of material for ROH activities to avoid detentions.
11. Responsible for proper stacking of good/bad material and keeping accountal thereof.
12. Responsible for prompt disposal of scrap/unserviceable material.
13. Responsible for timely placement of wagons according to next days programme.
14. Responsible for conducting technical meetings of supervisors in the Depot.
15. Responsible for maintaining records as per ISO/HQ requirements and making analysis to high light the facts.
16. Responsible for audit of maintained wagons in ROH depot.
17. Turning out defect-less wagons from ROH.
18. Inspections as per Railway Bd's letter no.99/AM(M)Inspections dt.16.8.99.
19. Computerization of ISO related work in the field of activity if assigned.
20. Responsible for prompt disposal of condemned wagon in ROH depot duly following laid down procedure.
21. Any other work given time to time by Mechanical Officers.

## **15. (SSE/C&W)/ROH/Field:**

***He is responsible for the following duties assigned to him –***

1. Overall incharge of the field activities of ROH Depot.
2. Responsible for proper deployment of staff, activity wise and maintaining discipline in ROH depot. Also responsible for arranging staff for line duties, stores, road-side stations and important other movements/works.
3. Responsible for managing material requirement in the depot/out side and ensure the availability of material on time.
4. Responsible for maintaining M&Ps in the ROH depot.
5. Responsible to meet the targeted out turn of ROH and ensure quality repairs of the wagon stock.
6. Responsible for releasing Wagons/BVZI earliest from ROH depot and in the jurisdiction for keeping minimum detention.
7. Liaison with all departments in respect of timely wagon movement to improve working conditions.
8. Responsible for ensuring proper stacking of good and bad materials/spares and proper accountal thereof.
9. Responsible to investigate and highlight the bad cases of material supply and to maintain record thereof.
10. Responsible for maintenance of fire extinguishers, material wagons and tower wagons also.
11. Responsible for proper record keeping of analysis of work and costing thereof.
12. Responsible to implement all procedure orders of work as per Maintenance manuals/ rule books / RDSO/HQ circulars/WAI etc.
13. Responsible for cleanliness and general up-keep of ROH depot shop in all respects.
14. Inspections as per Railway Bd's letter no.99/AM(M)Inspections dt.16.8.99. or as per wagon maintenance manual.
15. Computerization of ISO related work in the field of activity if assigned.
16. Responsible for warranty claims of items failed within warranty period.
17. Ensure proper stamping available on all the new/serviceable material. Materials not having stamping to be segregated and disposed of.
18. Any other work given time to time by Mechanical Officers.

## **16. SSE(C&W)/Store/ROH**

1. Ensure availability of material in Stores for use of ROH/Yard maintenance, Receiving/DN/UP Yard & other Working Points as per requirement.
2. Non availability of material if any to be chased and record thereof to be maintained.
3. Ensure up keep of ledgers and house keeping of main Store & sub-store.
4. Preparation of specifications for procurement of non stock items as and when required.
5. Scrutiny and certification of drawings and obtaining specifications of material, processing of stocking applications, follow up of indigenous developments and trials.
5. Field Exercise, control over MUF & AAC of Stock items for wagons.
6. Attending monthly technical meeting of Supervisors with DME/Sr DME.
7. Responsible for sending staff to other depot for chasing, procurement of material.
8. Responsible for maintaining record and Data entries pertaining to store items with the assistance of Store clerk.
9. Responsible for ISO related complete documentation, record keeping & general upkeep if assigned.
10. Over all incharge of computer cell and maintenance and repairing of items of computer cell.
11. Responsible for management and record keeping of condemn/Scrap items and process for survey/disposal etc.
12. Accountal and disposal of ferrous and non ferrous scrap material as per extent procedure.
13. Responsible for keeping watch over AAC & consumption pattern of vital items and process for revising (upward as well as downward) AAC.
14. Any other work given by mechanical officers time to time.

## **17. SSE (M&P)/ROH**

***He is responsible for the following duties assigned to him –***

1. Over all incharge of M&P Section of Depot. He will be responsible for maintenance and operation of M&P in Div./Depot
2. Maintenance of Wheel lathe machine of depot if provided.
3. Maintenance of all machines available in Machine shop & Compressors.
4. Maintenance of air pressure pipe line in ROH depot & Yard.
5. Car washer maintenance and availability of spares for passenger yard, if assigned.
6. Maintenance and repairing of vehicles of ROH Shed, preparation of history sheets and other repair/Fuel consumption record also.
7. Minor reclamation work in M&P section as and when required.
8. Maintenance and upkeep of Dead stock registers of M&P Section.
9. Record of receipts and issues of M&P items and raising of debits/credits.
10. Preparation of Schedule forms and Defect Cards for machines and plants.
11. Maintenance and overhauling of compressors & Rake test rigs/SWTR.
12. Condemnation of old Machines, plants, Welding sets kept in the M&P sections in Div./Depots.
13. Attending monthly technical meeting of Supervisors & giving feed back of previous discussions.
14. Record keeping and general upkeep in his section as per ISO requirement.
15. Initiation of Proposals of M&P and Works programme required in the depot/Yard.
16. Assisting to DBI in testing of pressure vessels and tanks.
17. Responsible for all type of trimmer work i.e. Battery bags, Tool Bag, Covers, Record registers & other protection covers for registers.
18. Ensure AMC of critical Machines like wheel lathe, EOT etc where adequate technical knowledge is not available.
19. Ensure availability of vital spares for M&P
20. Any other works given time to time by the Mechanical Officers.

## **18. SSE/C&W/Air Brake:**

***He is responsible for the following duties assigned to him –***

1. Overall incharge of the field activities of air brake system.
2. Responsible for proper deployment of staff in activity wise. Also responsible for arranging staff for stores and important other movements/works.
3. Responsible for air brake testing of all wagons placed in ROH depot & faults should be attended & rectified as per instructions laid down in Wagon Maintenance manual.
4. Responsible to attend all must change items of air brake system in ROH wagons.
5. Responsible for air brake testing of all ROH wagons in SWTR & maintaining of its record.
6. Liaison with other sections in the Depot in respect of timely fitment/release of wagon.
7. Responsible for overhauling of Cut off angle cock, DV, Brake Cylinder etc.
8. Responsible for proper maintenance & smooth working of SWTR & RTR.
9. Responsible for supply of sufficient quantity of overhauled DV to Yard for use on daily basis.
10. Responsible for ensuring proper stacking of good and bad materials/spares and proper accountal thereof.
11. Responsible to investigate and highlight the bad cases of material supply/unsatisfactory and to maintain record thereof.
12. Responsible for proper record keeping.
13. Responsible to implement all procedure orders of work as per Maintenance manuals/ rule books / RDSO circulars etc.
14. Responsible for cleanliness and general up-keep of the section.
15. Computerization of ISO related work in the field of activity if assigned.
16. Responsible for warranty claims of items failed within warranty period.
17. Ensure proper stamping available on all the new/serviceable material. Materials not having stamping to be segregated and disposed of.
18. Any other work given time to time by Mechanical Officers.

## **19. SSE/C&W/Bogie:**

***He is responsible for the following duties assigned to him –***

1. Overall incharge of the field activities of Bogie section.
2. Responsible for proper deployment of staff in activity wise. Also responsible for arranging staff for stores and important other movements/works.
3. Responsible to attend all wear & tear items of Bogie as per Technical Pamphlet G-95.
4. Responsible for timely hand over of repaired bogie to ROH section.
5. Responsible for procurement of new bogies, as per demand & inspection thereof.
6. Liaison with other sections in the Depot in respect of timely fitment/release of wagon.
7. Responsible for proper maintenance of tools & plant of the section.
8. Responsible for ensuring proper stacking of good and bad materials/spares and proper accountal thereof.
9. Responsible to investigate and highlight the bad cases of material supply/unsatisfactory and to maintain record thereof.
10. Responsible for proper record keeping.
11. Responsible to implement all procedure orders of work as per Maintenance manuals/ rule books / RDSO circulars etc.
12. Responsible for cleanliness and general up-keep of the section.
13. Computerization of ISO related work in the field of activity if assigned.
14. Responsible for warranty claims of items failed within warranty period.
15. Ensure proper stamping available on all the new/serviceable material. Materials not having stamping to be segregated and disposed of.
16. Any other work given time to time by Mechanical Officers.

## **20. SSE (ART/ARME):**

***He is responsible for the following duties assigned to him –***

1. Over all incharge of ART or ARME. He will be responsible for maintenance and operation of ART & ARME tools and equipments & accompany ART/ARME whenever ordered.
2. Responsible for efficient and safe working of MFD/LKAS equipments as well as other ART tools and staff at accident site.
3. Ensure liaison with other departments during restoration at accident site.
4. Responsible for proper nomination of staff for making team for each activity before reaching at accident site.
5. Responsible for collecting information regarding nature of accident and involvement of number of coaches/wagons in the accident.
6. Responsible for filling up schedule form of hydraulic machines other tools and equipments as per maintenance manual.
7. Responsible for communicating progress of relief & restoration time to time to control office on phone with consultation of site incharge.
8. Responsible for safe running of ART during shunting at block stations and pushing back operations.
9. Responsible for timely maintenance schedules of ART/ARME coaches & wagons and timely testing and mock drill thereof.
10. Responsible for maintaining complete record of availability status of items as per standard list, HLC recommendations & Board/ HQrs. instructions.
11. Responsible for complete maintenance of ARME equipments and their AMC.
12. Proper record keeping as per ISO Norms & HQ requirement.
13. Examination of tower wagon of nominated depots if assigned.
14. Maintenance and overhaul of Hydraulic Jacks and compressors of ART.
15. Maintenance and up keep of Dead Stock register of ART/ARME.
16. Attending monthly Technical meeting of supervisors.
18. Computerization and ISO system related work in his field of activity if assigned.
19. Ensure inspection of ART & ARME vide Rly.Bd's L.No.99/AM(M)/Insp. dtd.16.08.99.
20. Any other work given time to time by the Mechanical Officers.

**Note:** Detailed duties are given in Maintenance & Operation Manual for ARTs/ARMEs/140T Cranes-Dec-2015.



## **21. SSE/ SPART**

*He is responsible for the following duties assigned to him –*

### **Technical:**

#### **Daily check:**

##### **1 Engine:**

- a) Check & record the fuel oil, lube oil and water level. Top up if required.
- b) Check for, leakages, loose worn out or damaged parts. Take appropriate action to rectify or replace.

##### **2. Transmission :**

Check Oil level and top up if required.

##### **3 Axle Drive :**

Check axle driver oil level and top up, if required.

##### **4 Air compressor :**

Check air compressor oil level and top up, if required.

##### **5 Hydraulic system :**

Check hydraulic system tank oil level & top up if necessary.

#### **In addition to above, following checks to be done :**

1. Start both the engines one by one for checking of smooth functioning.
2. Maintain B.P., FP and MR air pressure and record in the register
3. Check functioning of brakes system equipments
4. Check the leakages in all the system and attend them. Check for any unusual noises, loose or damage parts.
5. Check engine lube oil pressure at idle as well as at Max speed & record (After reaching to running temp. of engine up to specified limit.)
6. Check head lights, flasher lights and tail lamps of both end operating cabs.
7. Check the working of horns, wipers, guard bell & emergency bell.
8. Visually inspect fan for its proper working.
9. Drain Water / Sediments from the system.
10. Check for any loose or frayed belts.
11. Check the condition of engine batteries.
- \* Move the vehicle for a kilometer daily and return back, this will prove the operation and reversing.

**Once in a week:** Take the vehicle on main line for a stretch wherein vehicle can achieve max permissible sectional speed and return back. This proves the health of power packs and capability.

## **Monthly check List for SPART**

### **1. Start the engines and check:**

#### **a) Engine:-**

- i) Leakages in lube oil system and arrest them
- ii) Leakages in cooling water system and arrest them.
- iii) Leakages in hydraulic oil system and arrest them.
- iv) Record the lube oil pressure at idle and 8<sup>th</sup> notch.
- v) Check the functioning of lube oil and water temp. gauges.
- vi) Check function of water level sensor.

#### **b) Transmission :**

- i) Leakages in transmission oil system and arrest them.
- ii) Leakages in pneumatic system and arrest them.
- iii) Check working of transmission oil temp. gauge.

#### **c) Compressor**

- i) leakages in air system and arrest them
- ii) Check function of unloader valve.
- iii) Check and record the MR Pressure, BP & FP pressures.
- iv) Check function of horns.
- v) Drain condensate from MR Tanks/Reservoirs
- vi) Check functioning of wipers and its arms.
- vii) Check the brake cylinder pressure.

#### **f) BEHR FAN**

- i) Check the leakages of hydraulic oil in the system & working of pump.
- ii) Clean radiator cores and hydraulic oil cooler.

### **2. Shut down the engine and check.**

#### **a) Engine**

- i) Check lube oil level and fill up if necessary.
- ii) Check all foundation bolts for tightness.
- iii) Check water level and fill up if necessary.
- iv) Check hydraulic oil level and adjust if necessary.

#### **b) Transmission:**

- i) Check transmission oil level and fill up if necessary
- ii) Check all foundation bolts for proper tightness.
- iii) Check all oil pipe lines and pneumatic pipe connections for tightness.

#### **c) Compressor**

- i) Check oil level and adjust if necessary
- ii) Check all foundation bolts for tightness.
- iii) Check air filter and clean it if necessary
- iv) Check belt tension and adjust it if necessary.

- d) Axle Drive:**
  - i) Check oil level and adjust if necessary
  - ii) Check all foundation mounting bolts for proper tightness.
- e) CARDEN SHAFT**
  - i) Check cardon shafts assembly flange bolts for tightness and ensure greasing of all cardon shfts.
- f) Alternator**
  - Check alternator belt tension and adjust if necessary.
- g) Brake system**
  - i) Check the condition of brake blocks, change them if necessary.
  - ii) Check the mounting of brake gearing .

## **CONTROL SYSTEM AND INSTRUMENTATION**

- i) Check all electrical connections for tightness.
- ii) Secure electrical connections and all the mounted devices.
- iii) Check functioning of all cutout toggle switches.
- iv) Check master controller function.

### **Note:**

- i) Alternators maintenance by train lighting staff should be performed as per the schedule maintenance of other coaches.
- ii) Remaining coach maintenance of DPC & DTC should be arranged as per the other coaches maintenance schedule programmes.

### ***Check other following parameters also:***

- a. Compressor Oil
- b. Axle Drive Oil
- c. Transmission Oil
- d. Engine Oil
- e. Hydraulic tank oil
- f. Lubricating oil
- g. Cooling system: Min. recommended operating temp and Max. recommended operating temp.

**APPENDIX-XII****Unit Exchange Spares for Freight stock in ROH Depots.**

**(Ref: Item No. 01 of Meeting in Railway Board on “Revised Wagon Maintenance Manual” on 14.08.2015).**

On the basis of discussions in the above referred meeting held at Railway Board on 14.08.2015 for providing unit exchange spares for freight stock in ROH/POH in Revised Wagon Maintenance Manual has been worked out. A letter for providing unit exchange items was circulated by CAMTECH to All CRSEs (Freight), CWEs and CWMs (Wagon Workshops) in this regard on 31.08.2015.

After getting feedback from Zonal Railways and visiting Freight ROH Depots, NKJ/WCR, BSL/CR and Bhilai/SECR, unit exchange spares for Freight Stock are as under.

<b>Sr. No.</b>	<b>Name of the component</b>	<b>Qty. per Wagon</b>	<b>Proposed yard stick for UES for ROH Depots (Basis on the monthly outturn of ROH depots)</b>
01	Bogie Complete with wheel sets, bolster, brake rigging etc.	02 Sets	03%
02	Wagon Wheel sets with CTRBs	04 Sets	08%
03	CBC assembly	02 Nos.	03%
05	Distributor valve	01 Nos.	10%
06	Brake Cylinder	01 Nos.	12%

**[ Railway Board’s letter No. 2008/M(N)/951/28 dated 24.11.2015 ]**